

Dear customer,

At Impact Robotics, our mission is to make a significant impact with every robot deployed worldwide. Our products streamline robot deployment by simplifying it and positively enhancing our partners' profitability.

For any inquiries or product support, please contact us at:
support@impact-robotics.com.

Best Regards,
Impact Robotics team

Copyright:

The manual and all its contents are protected by copyright, with Impact Robotics Private Limited as the rightful author. All rights are exclusively held by the author. Unauthorized reproduction, processing, distribution (including sharing with third parties), translation, or any other form of usage, even if it's just excerpts from the manual, are strictly forbidden without obtaining written consent from the author.

Technical changes:

Only Impact Robotics holds the discretion to implement specific technical and structural adjustments aimed at enhancing the product's quality and functionality.

© Impact Robotics Private Limited
All rights reserved.

Document number: 9 101 0009
Edition: 01.01 | Sep. 20, 24 | En

Impact Robotics Private Limited
casemagiQ®

267 Kilpauk Garden Road,
Chennai 600 010 India
Tel: +91 44 4294 9000

support@impact-robotics.com
www.impact-robotics.com

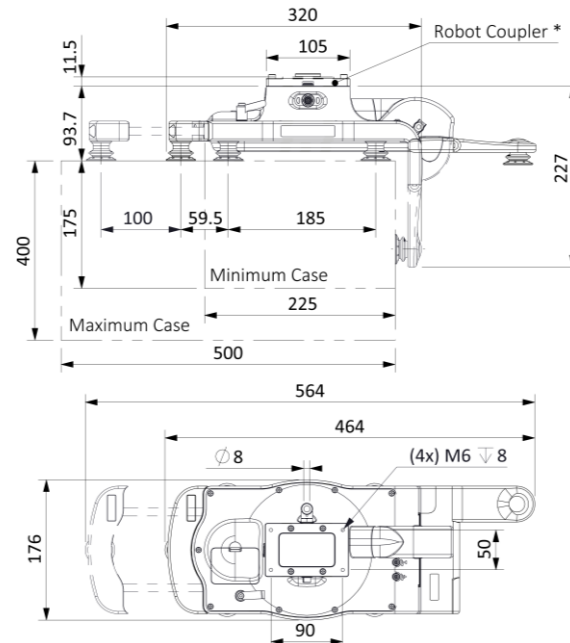

Figure 1: casemagiQ Drawing; the phantom lines denote couplers. All dimensions in mm.

More information on the product and all documentation can be downloaded at <https://www.impact-robotics.com>

1) Variants

This operating manual applies to the following variants:

- casemagiQ CM100

2) Safety Considerations

2.1) Compressed Air

Ensure to use a FRL (Filter Regulator Lubricator) and follow the quality standards of ISO 8573-1:7:4:4 for compressed air.

2.2) Personnel Qualifications

Only authorized personnel with a working knowledge of handling pneumatic and electrical circuits should operate the product. Anyone handling the product should have understood the product manual.

2.3) Construction changes

One can not make constructional changes to the product without explicit permission from Impact Robotics. At this moment, only authorized personnel from Impact Robotics can implement constructional changes to our product.

2.4) Notes for assembly

One will need the following tools to complete the integration of casemagiQ.

- Hex Key – 4 mm
- Hex Key – 5 mm
- Minus Screwdriver set

2.5) Notes for operation

Always switch-off casemagiQ by disconnecting the I/O cable before adding or

removing accessories. Before switching off, neutralise the pressure inside by shutting off the pneumatic supply and actuating the main vacuum using the URcap (Refer to operations manual).

3) Scope of supply

List of Parts	Quantity
casemagiQ	1
Protective Foam	1
Installation Manual	1

4) casemagiQ

casemagiQ is a compact Universal Case Forming EOAT designed to seamlessly form cases of wide range of dimensions. The compact design of casemagiQ is ideal for case forming / carton erection applications with minimal footprint.

5) Parts of casemagiQ

The following are the parts of casemagiQ as shown in Figure 2, Figure 3 & Figure 4:

5.1) Robot Mounting Face

As in Figure 2, here the robot coupler is mounted onto casemagiQ.

5.2) Compressed Air Inlet

As in Figure 2, casemagiQ requires only a single compressed air inlet to actuate all suction cups and the folding flap.

5.3) I/O Connector

All the communication and electrical power is provided by 8-pin M8 female connector.

5.4) Status Indicator

The status of casemagiQ is communicated to the operator using the Status Indicator.

5.5) Case Forming Flap

The case folding flap bends and shapes the flat cases / cartons into an open cuboid. Thus, ensuring uniformly aligned walls.

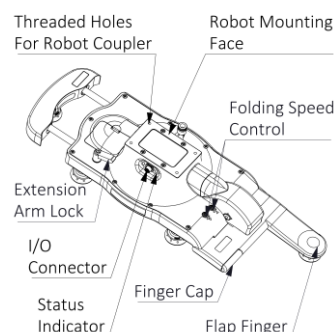

Figure 2: Parts of casemagiQ

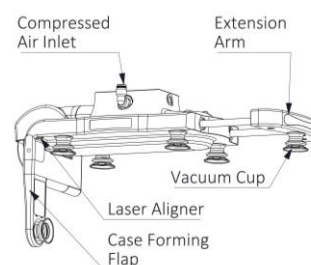

Figure 3: Parts of casemagiQ

5.6) Flap Speed Control

As cases/cartons come in variety of thicknesses, the built-in flap speed control screws can increase or decrease the opening and closing speeds of the case forming flap.

5.7) Flap Sensors

To know if the flap is closed or open in the UR+ menu, there are built-in sensors.

5.8) Flap Finger & Cap

The flap finger is the extension in the flap with the flap vacuum. It can be interchanged with the flap cap.

5.9) Laser Aligner

To position the casemagiQ right at the fold of the case to program quickly, casemagiQ comes with a built-in laser aligner.

5.10) Extension & Lock

By turning the Extension Arm Lock, the Extension Arm can extend by 100 mm to form cases up to 500 x 400 x 400 mm.

5.11) Exhaust with Silencer

The built-in silencer that keeps the exhaust noise to be less than 50dB.

5.12) Vacuum Generator

The built-in vacuum generator produces vacuum pressure up to -870 mbar.

5.13) Vacuum Suction Cups

Hold cartons with industry standard polyurethane suction cups.

5.14) Maintenance Hatch

Access the silencer, ejector retainer and the vacuum generator to be able to clean them.

6) Selection of Accessories

Here are casemagiQ accessories:

6.1) Robot Coupler

casemagiQ is coupled to the robot tool flange using Robot Couplers. We provide Robot Couplers in both ISO and non-ISO standards. Visit our website to know more.

6.2) Pneumatic tubing

casemagiQ needs one 8 mm pneumatic tube to provide compressed air. It can be any industry standard nylon or polyurethane tube (not sold by Impact Robotics).

6.3) I/O Cable

I/O cable is for connecting to the I/O Connector of casemagiQ. There are 2 variants:

- I/O Cable (0.2 m) is for the Tool I/O Port of the robot. It has 8 pin M8 Male connector on one end and 8 pin M8 Female connector on the other end. This cable is ideal for robots like Universal Robots, Fanuc, etc.
- I/O Cable (5 m) has an 8 pin M8 Male connector on one end and free leads on the other end. This is ideal for connecting directly to the controller for any brand of robots.

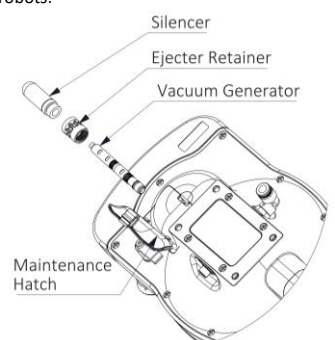

Figure 4: Parts of casemagiQ

7) Technical details

7.1) Specifications

Model	CM100
Part Number	6 105 1001
Operating Medium	Compressed Air
Weight	1350 g
Dimensions (L x W x H)	464 x 176 x 94 mm
Max. case dimension	500 x 400 x 400 mm
Min. case dimension	240 x 140x 165 mm
Max. load	3 kg
Pneumatics	
Airflow rate	85 slpm/ 3 scfm
Vacuum flow rate	15 slpm/ 0.53 scfm
Air consumption	100 slpm/ 3.53 scfm
Maximum vacuum pressure	-870 mbar/ -12.62 psi
Maximum operating pressure	6 bar / 87 psi
Communication	
I/O Connector	M8 8pin female connector
Air inlet	Ø8 mm tube quick connector
Interface - Robot	
Robot mounting	Robot Coupler
Power	
Operating voltage	24V DC
Peak Operational current	554 mA
Peak Operational current	650 mA
Environment	
Ambient temperature range	+5°C to 50°C
Noise level	<50 dB
Ingress Protection	IP54

7.2) Tool Center Point & Center of Gravity

The reference for the TCP and the COG is from the Robot Mounting Face (Figure 6).

TCP of Mounting Face 1:

X: 0.0; Y: 0.0; Z: 93.7;
R_x: 0; R_y: 0; R_z: 0.

Center of Gravity:

Weight: 1.352 Kg

Not Extended:

Flap off: C_x: 14.4; C_y: -2.6; C_z: 53.0;
Flap on: C_x: -15.2; C_y: -2.6; C_z: 58.3.

Extended:

Flap off: C_x: 4.2; C_y: -2.6; C_z: 53.0;
Flap on: C_x: 5.0; C_y: -2.6; C_z: 58.3.

For the above COG values, the consideration is that the flap finger on the same side of the Compressed Air Inlet. If it is on the same side of the I/O Connector, change all Y axis values to 0.

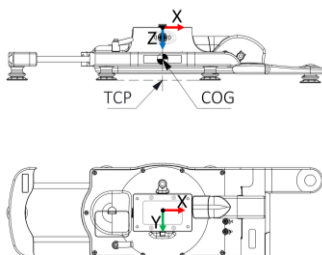

Figure 6: TCP & COG

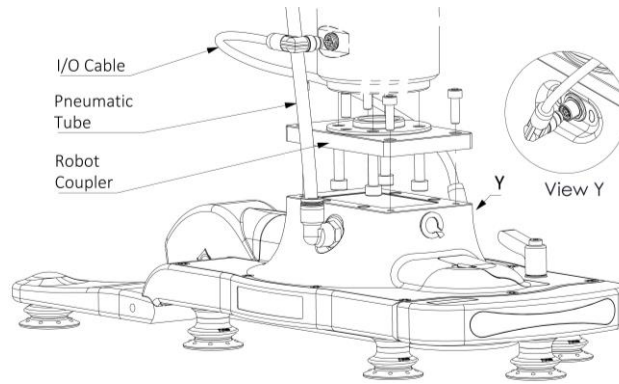

Figure 5: Assembly of casemagiQ

8) Assembly

The assembly order is dependent on the application purview of the integrator.

8.1) Robot coupler to robot

To mount the robot coupler to the robot, it comes with fasteners and dowel pins appropriate to robot's tool flange ISO. Now, mount the robot coupler to the robot.

8.2) casemagiQ to Robot coupler

Use the fasteners provided to fasten the robot coupler to casemagiQ.

WARNING

While mounting the robot coupler to casemagiQ, always consider the maximum screw engagement and tightening torque as given in Figure 7.

8.3) I/O Cable to the robot

To power up and communicate with casemagiQ, use the I/O Cable (0.2 m) or I/O Cable (5 m) depending on the application. 8 pin male connector connects to the casemagiQ front cover. The female connector of the I/O Cable (0.2 m) goes to the communication port in the robot arm.

If using I/O cable (5 m), then use the free leads to connect to the robot controller using any industry standard converters to other industry standard ports.

8.4) Pneumatic tube to casemagiQ

casemagiQ requires an 8 mm pneumatic tube to supply the compressed air. Connect it to the casemagiQ back cover.

WARNING

While installing the pneumatic tube or the I/O Cable, ensure that the tube or the cable have enough leeway for robot joint rotation. Have trial runs to ensure that the robot motion does not damage the I/O connector and compressed air inlet.

8.5) Flap finger & cap

To ensure that the flap finger is not in the way of taping head when taping the bottom of cases, it can be interchanged with the flap cap.

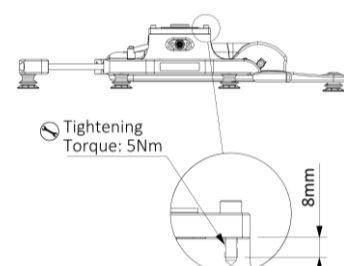

Figure 7: Maximum screw engagement for CM100's robot couplers

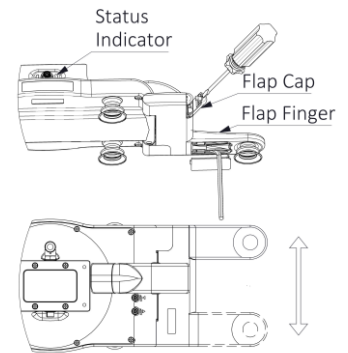

Figure 9: Swapping flap finger & cap

First, the flap cap can be opened using a Minus Screwdriver as shown in Figure 9. Next, open the Finger Hatch as the bottom face of the Flap Finger to reveal the two Allen Head Screws. Using a standard hex key, unscrew the screws to be able to slide out the Flap Finger.

Now, interchange the Flap Finger with the Flap Cap by following the same process in reverse.

9) Operations

Now that the assembly is completed, time to switch-on casemagiQ.

9.1) For Universal Robots

For Universal Robots, URcap must be installed to operate the casemagiQ. Refer to the "casemagiQ Operations Manual for Universal Robots" to know more.

9.2) For Other Robots

For other robots, use the MODBUS RTU (RS485) communication to control the casemagiQ. Refer to the "Operations Manual for MODBUS" to know more.

9.3) Flap Speed Control Screws

For cases/cartons of varying thickness, the flap speed needs to be changed such that for thinner cases, the closing speed is slower. Both the opening and closing speeds can be controlled individually.

9.4) Operational Precautions

When installing and operating casemagiQ, the following points need to be considered:

1. Ensure to handle the cable connectors with care during installation & dismantling to prevent damaging the connector pins.
2. While routing, ensure that the robot joints do not pinch or stretch the electrical cable and the pneumatic tube.
3. Ensure a backup power supply is provided for the robot.
4. Ensure that the air pressure does not drop even during power failure.

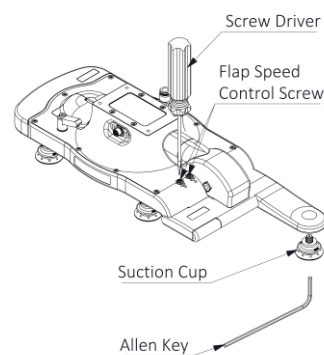

Figure 8: Flap Speed Control Screws and Suction cup replacement

9.5) Electrical Precautions

1. Ensure the circuit is not live when connecting or disconnecting the I/O cables or the sensors.
2. Each sensor connected must not exceed a maximum operating current of 40 mA.

9.6) Mechanical Precautions

1. The maximum screw engagement for the robot coupler is given in Figure 7.
2. The tightening torque of the robot coupler is ±5% of the value given in Figure 7.

10) Maintenance

10.1) Suction Cup Replacement

The suction cups of casemagiQ are part of the consumables list that will get damaged due to wear and tear over time. Hence, it is important to regularly check them and replace them. As shown in Figure 8, use standard Hex key to easily unscrew the suction cups and replace them.

10.2) General Information

Make sure to use the suitable fasteners provided with the product.

10.3) Periodic Maintenance

The frequency of the periodic maintenance is dependent on the application and the environment. Hence, must be determined by the end user/ integrator.

1. Weekly, remove the pneumatic tube from the inlet and look for moisture or dust build-up. If there is a noticeable deposition of dust or moisture, then do maintenance for the air compressor.
2. Weekly, ensure periodic maintenance of the FRL.
3. Weekly, clean the product exterior and the suction cups from any foreign material buildup.
4. Monthly, check the Silencer and Vacuum Generator for material build up and clear it or replace them, if need be, as shown Figure 4.
5. Quarterly, check all suction cups for damage and replace them, if need be, as shown in Figure 8.