

# EPSON

SCARA ROBOT

*T series*

MANIPULATOR MANUAL

Rev.9

EM187R3737F

MANIPULATOR MANUAL    T series    Rev.9

SCARA ROBOT

# *T series Manipulator Manual*

Rev.9

Copyright © 2017-2018 SEIKO EPSON CORPORATION. All rights reserved.

## FOREWORD

Thank you for purchasing our robot products.

This manual contains the information necessary for the correct use of the manipulator.

Please carefully read this manual and other related manuals before installing the robot system.

Keep this manual handy for easy access at all times.

## WARRANTY

The Manipulator and its optional parts are shipped to our customers only after being subjected to the strictest quality controls, tests, and inspections to certify its compliance with our high performance standards.

Product malfunctions resulting from normal handling or operation will be repaired free of charge during the normal warranty period. (Please ask your Regional Sales Office for warranty period information.)

However, customers will be charged for repairs in the following cases (even if they occur during the warranty period):

1. Damage or malfunction caused by improper use which is not described in the manual, or careless use.
2. Malfunctions caused by customers' unauthorized disassembly.
3. Damage due to improper adjustments or unauthorized repair attempts.
4. Damage caused by natural disasters such as earthquake, flood, etc.

Warnings, Cautions, Usage:

1. If the Manipulator or associated equipment is used outside of the usage conditions and product specifications described in the manuals, this warranty is void.
2. If you do not follow the WARNINGS and CAUTIONS in this manual, we cannot be responsible for any malfunction or accident, even if the result is injury or death.
3. We cannot foresee all possible dangers and consequences. Therefore, this manual cannot warn the user of all possible hazards.

## TRADEMARKS

Microsoft, Windows, and Windows logo are either registered trademarks or trademarks of Microsoft Corporation in the United States and/or other countries. Other brand and product names are trademarks or registered trademarks of the respective holders.

## NOTICE

No part of this manual may be copied or reproduced without authorization.

The contents of this manual are subject to change without notice.

Please notify us if you should find any errors in this manual or if you have any comments regarding its contents.

## MANUFACTURER

**SEIKO EPSON CORPORATION**

## Regarding battery disposal



The crossed out wheeled bin label that can be found on your product indicates that this product and incorporated batteries should not be disposed of via the normal household waste stream. To prevent possible harm to the environment or human health please separate this product and its batteries from other waste streams to ensure that it can be recycled in an environmentally sound manner. For more details on available collection facilities please contact your local government office or the retailer where you purchased this product. Use of the chemical symbols Pb, Cd or Hg indicates if these metals are used in the battery.

This information only applies to customers in the European Union, according to DIRECTIVE 2006/66/EC OF THE EUROPEAN PARLIAMENT AND OF THE COUNCIL OF 6 September 2006 on batteries and accumulators and waste batteries and accumulators and repealing Directive 91/157/EEC and legislation transposing and implementing it into the various national legal systems.

For other countries, please contact your local government to investigate the possibility of recycling your product.

The battery removal/replacement procedure is described in the following manuals:

T series manipulator manual *Maintenance: 14.2 Replacing the Lithium Battery*

# Before Reading This Manual

This section describes what you should know before reading this manual.

## Structure of Robot System

The T series Manipulators can be used with the following combinations of software.

T3-401S		Controller Firmware
		Ver.7.3.51.1 or later
EPSON RC+ 7.0	Before Ver.7.3.0	!!!
	Ver.7.3.1 or later	OK

T6-602S		Controller Firmware
		Ver.7.3.53.0 or later
EPSON RC+ 7.0	Before Ver.7.3.3	!!!
	Ver.7.3.4 or later	OK

OK: Compatible All functions of the EPSON RC+ 7.0 and the robot system are available.

!!!: Compatible Connection is OK. It is recommended to use the following versions or later. Display or control may not be operated properly.

T3-401S: EPSON RC+7.0 Ver.7.3.1

T6-602S: EPSON RC+7.0 Ver.7.3.4

## Shape of Motors

The shape of the motors used for the Manipulator that you are using may be different from the shape of the motors described in this manual because of the specifications.

## Setting by Using Software

This manual contains setting procedures by using software. They are marked with the following icon.







## Setup & Operation

<b>1. Safety</b>	<b>3</b>
1.1 Conventions.....	3
1.2 Design and Installation Safety.....	3
1.2.1 Strength of the Ball Screw Spline.....	4
1.3 Operation Safety.....	5
1.4 Emergency Stop.....	7
1.5 Emergency Movement Without Drive Power.....	9
1.6 ACCELS Setting for CP Motions.....	10
1.7 Labels.....	11
<b>2. Specifications</b>	<b>13</b>
2.1 Features of T series Manipulators.....	13
2.2 Model Number.....	14
2.3 Part Names.....	15
2.3.1 T3.....	15
2.3.2 T6.....	16
2.4 Outer Dimensions.....	17
2.4.1 T3.....	17
2.4.2 T6.....	18
2.5 System Example.....	19
2.6 Specifications.....	20
2.7 How to Set the Model.....	23
<b>3. Environments and Installation</b>	<b>24</b>
3.1 Environmental Conditions.....	24
3.2 Base Table.....	25
3.3 Mounting Dimensions.....	26
3.4 Unpacking and Transportation.....	28
3.5 Installation Procedure.....	29
3.6 Power Supply.....	30
3.6.1 Specifications.....	30
3.6.2 AC Power Cable.....	30
3.6.3 Breaker.....	31
3.6.4 Power Unit.....	32
3.6.5 Grounding.....	33
3.7 Connecting the Cables.....	34
3.7.1 Connection Example.....	35
3.7.2 Noise Countermeasures.....	36
3.8 Pneumatic Tubes.....	37
3.9 Relocation and Storage.....	39
3.9.1 Precautions for Relocation and Storage.....	39
3.9.2 Relocation.....	40

<b>4. Setting of End Effectors</b>	<b>41</b>
4.1 Attaching an End Effector .....	41
4.2 Attaching Cameras and Valves.....	42
4.3 Weight and Inertia Settings.....	43
4.3.1 Weight Setting .....	43
4.3.2 Inertia Setting .....	45
4.4 Precautions for Auto Acceleration/Deceleration of Joint #3 .....	50
<b>5. Motion Range</b>	<b>51</b>
5.1 Motion Range Setting by Pulse Range (for All Joints).....	51
5.1.1 Max. Pulse Range of Joint #1 .....	52
5.1.2 Max. Pulse Range of Joint #2 .....	52
5.1.3 Max. Pulse Range of Joint #3 .....	53
5.1.4 Max. Pulse Range of Joint #4 .....	53
5.2 Motion Range Setting by Mechanical Stops .....	54
5.2.1 Setting the Mechanical Stops of Joints #1 and #2.....	54
5.2.2 Setting the Mechanical Stop of Joint #3.....	56
5.3 Setting the Cartesian (Rectangular) Range in the XY Coordinate System of the Manipulator (for Joints #1 and #2) .....	58
5.4 Standard Motion Range .....	58
<b>6. Operation Mode &amp; LED</b>	<b>59</b>
6.1 Overview .....	59
6.2 Switch Operation Mode.....	59
6.3 Program Mode (AUTO).....	60
6.3.1 What is Program Mode (AUTO)? .....	60
6.3.2 Setup from EPSON RC+ 7.0.....	60
6.4 Auto Mode (AUTO) .....	61
6.4.1 What is Auto mode (AUTO)? .....	61
6.4.2 Setup from EPSON RC+ 7.0.....	61
6.4.3 Setup from Control Device .....	62
6.5 LED.....	63
<b>7. Development PC Connection Port</b>	<b>64</b>
7.1 What is Development PC Connection Port.....	64
7.2 Precaution .....	65
7.3 Software Setup and Connection Check.....	65
7.4 Disconnection of Development PC and Manipulator.....	66

<b>8. Memory Port</b>	<b>67</b>
8.1 What is Controller Status Storage Function?.....	67
8.2 Before Using Controller Status Storage Function.....	67
8.2.1 Precautions.....	67
8.2.2 Adoptable USB Memory.....	67
8.3 Controller Status Storage Function.....	68
8.3.1 Controller Status Storage.....	68
8.3.2 Load Data with EPSON RC+ 7.0.....	69
8.3.3 Transfer with E-mail.....	70
8.4 Details of Data.....	71
<b>9. LAN (Ethernet Communication) Port</b>	<b>72</b>
9.1 What is the LAN (Ethernet Communication) Port.....	72
9.2 IP Address.....	72
9.3 Changing Manipulator IP Address.....	73
9.4 Connection of Development PC and Manipulator with Ethernet.....	74
9.5 Disconnection of Development PC and Manipulator with Ethernet..	75
<b>10. TP Port</b>	<b>76</b>
10.1 What is the TP Port?.....	76
10.2 Teach Pendant Connection.....	76
<b>11. EMERGENCY</b>	<b>77</b>
11.1 Safeguard Switch and Latch Release Switch.....	77
11.1.1 Safeguard Switch.....	78
11.1.2 Latch Release Switch.....	78
11.1.3 Checking Latch Release Switch Operation.....	79
11.2 Emergency Stop Switch Connection.....	79
11.2.1 Emergency Stop Switch.....	79
11.2.2 Checking Emergency Stop Switch Operation.....	80
11.2.3 Recovery from Emergency Stop.....	80
11.3 Pin Assignments.....	81
11.4 Circuit Diagrams.....	82
11.4.1 Example 1: External emergency stop switch typical application.....	82
11.4.2 Example 2: External safety relay typical application.....	83
<b>12. Standard I/O Connector</b>	<b>84</b>
12.1 Input Circuit.....	84
12.1.1 Typical Input Circuit Application.....	85
12.1.2 Typical Input Circuit Application 2.....	85
12.1.3 Pin Assignments of Input Circuit.....	86
12.2 Output Circuit.....	86

## TABLE OF CONTENTS

---

12.2.1	Typical Output Circuit Application 1 .....	87
12.2.2	Typical Output Circuit Application 2 .....	87
12.2.3	Pin Assignments of Output Circuit .....	88
12.3	I/O Cable Product Procedure .....	89
12.3.1	I/O Cable Connecting Method .....	89
12.3.2	How to Fix the I/O Cable .....	89
<b>13. Hand I/O Connector</b>		<b>90</b>
13.1	Power Supply Specifications .....	90
13.2	Input Circuit .....	91
13.2.1	Typical Input Circuit Application 1 .....	91
13.2.2	Typical Input Circuit Application 2 .....	91
13.3	Output Circuit .....	92
13.3.1	Typical Output Circuit Application 1 .....	92
13.3.2	Typical Output Circuit Application 2 .....	92
13.4	Pin Assignments .....	93
13.5	How to Control Hand I/O .....	93
<b>14. I/O Remote Settings</b>		<b>95</b>
14.1	I/O Signal Description .....	96
14.1.1	Remote Input Signals .....	96
14.1.2	Remote Output Signals .....	100
14.2	Timing Specifications .....	103
14.2.1	Precautions for Remote Input Signals .....	103
14.2.2	Timing Diagram for Operation Execution Sequence .....	103
14.2.3	Timing Diagram for Program Execution Sequence .....	103
14.2.4	Timing Diagram for Safety Door Input Sequence .....	104
14.2.5	Timing Diagram for Emergency Stop Sequence .....	104
<b>15. SD Card Slots</b>		<b>105</b>
<b>16. RESET Switch</b>		<b>106</b>
<b>17. Fieldbus I/O</b>		<b>107</b>

# Maintenance

<b>1. Safety Maintenance</b>	<b>111</b>
<b>2. General Maintenance</b>	<b>112</b>
2.1 Maintenance Inspection .....	112
2.1.1 Schedule for Maintenance Inspection .....	112
2.1.2 Inspection Point .....	113
2.2 Overhaul (Parts Replacement).....	114
2.3 Greasing .....	116
2.4 Tightening Hexagon Socket Head Cap Bolts.....	117
2.5 Matching Origins.....	117
2.6 Layout of Maintenance Parts .....	118
<b>3. Manipulator Structure</b>	<b>119</b>
<b>4. Alarm</b>	<b>121</b>
4.1 Maintenance .....	122
4.1.1 Manipulator Maintenance Information.....	122
4.1.2 Manipulator Maintenance Information.....	122
4.2 Maintenance Information.....	123
4.2.1 How to View the Maintenance Information.....	123
4.2.2 How to Edit the Maintenance Information .....	124
4.2.3 Alarm Notifying Method .....	125
4.2.4 How to Cancel the Alarm.....	125
<b>5. Backup and Restore</b>	<b>126</b>
5.1 What is the Backup Controller Function.....	126
5.2 Backup Data Types .....	126
5.3 Backup.....	127
5.4 Restore .....	128
<b>6. Firmware Update</b>	<b>131</b>
6.1 Updating Firmware .....	131
6.2 Firmware Upgrade Procedure .....	131
6.3 Manipulator Recovery .....	134
6.4 Firmware Initialization Procedure.....	135
<b>7. Covers</b>	<b>137</b>
7.1 Arm Top Cover .....	139
7.2 Arm Bottom Cover .....	140
7.3 Power Cable Cover .....	140
7.4 Connector Plate.....	141

## TABLE OF CONTENTS

---

7.5	Power Unit Cover .....	143
7.6	Base Side Cover .....	144
7.7	User Plate.....	145
<b>8.</b>	<b>Cable</b> .....	<b>146</b>
8.1	Replacing Cable Unit .....	146
8.2	Insert or Pull out of Power Cable .....	154
<b>9.</b>	<b>Joint #1</b> .....	<b>155</b>
9.1	Replacing Joint #1 Motor .....	156
9.2	Replacing Joint #1 Reduction Gear Unit.....	166
<b>10.</b>	<b>Joint #2</b> .....	<b>169</b>
10.1	Replacing Joint #2 Motor .....	170
10.2	Replacing Joint #2 Reduction Gear Unit.....	174
<b>11.</b>	<b>Joint #3</b> .....	<b>177</b>
11.1	Replacing Joint #3 Motor .....	178
11.2	Replacing the Timing Belt .....	184
11.3	Replacing the Brake.....	185
11.4	Checking the Timing Belt Tension (Z Belt) .....	186
<b>12.</b>	<b>Joint #4</b> .....	<b>187</b>
12.1	Replacing Joint #4 Motor .....	188
12.2	Replacing the Timing Belt .....	194
12.2.1	U2 Belt (T6) .....	195
12.2.2	U1 Belt (T6) .....	200
12.2.3	U Belt (T3) .....	201
12.3	Checking the Timing Belt Tension .....	202
<b>13.</b>	<b>Ball Screw Spline Unit</b> .....	<b>203</b>
13.1	Greasing the Ball Screw Spline Unit.....	204
13.2	Replacing the Ball Screw Spline Unit .....	205
<b>14.</b>	<b>Lithium Battery, SD Card, Boards, and Filter</b> .....	<b>208</b>
14.1	Replacing the CPU/DPB Boards.....	210
14.2	Replacing the Lithium Battery .....	213
14.3	Replacing the SD Card .....	214
14.4	Replacing the Power Board .....	215
14.4.1	Replacing the Air Filter .....	215
14.4.2	Replacing the Power Board .....	216

<b>15. LED Lamp Unit</b>	<b>218</b>
<b>16. Calibration</b>	<b>220</b>
16.1 About Calibration .....	220
16.2 Calibration Procedure.....	221
16.3 Accurate Calibration of Joint #2 .....	231
16.4 Reference: Calibration Procedure Without Using Calibration Wizard .....	233
<b>17. Restrictions</b>	<b>237</b>
17.1 Commands Cannot Use .....	237
17.2 Commands Cause Motion Error If Specifying RS-232C.....	237
17.3 Commands Cause Error.....	238
17.3.1 6-axis Robot Command.....	238
17.3.2 Conveyor Tracking Commands.....	238
17.3.3 PG Commands .....	239
17.3.4 R-I/O Commands.....	239
17.3.5 Force Sensing Commands.....	239
17.3.6 Others (FineDist) .....	239
17.3.7 Others (HealthCalcPeriod) .....	239
17.3.8 Other (ChDisk).....	239
17.4 Restrictions of Functions .....	240
17.4.1 TP3 .....	240
17.4.2 Loop Processing.....	240
17.4.3 Camera Searching by CV1/CV2.....	241
17.4.4 Restore the Data of Backup Controller Function .....	241
<b>18. Error Code Table</b>	<b>242</b>
<b>19. Maintenance Parts List</b>	<b>242</b>
19.1 T3.....	243
19.2 T6.....	244
<b>Appendix A: Open Source Software License for T series</b>	<b>245</b>





# Setup & Operation

This volume contains information for setup and operation of the T series Manipulators.

Please read this volume thoroughly before setting up and operating the Manipulators.





# 1. Safety

Installation and transportation of manipulators and robotic equipment shall be performed by qualified personnel and should conform to all national and local codes. Please read this manual and other related manuals before installing the robot system or before connecting cables.

Keep this manual handy for easy access at all times.

## 1.1 Conventions

Important safety considerations are indicated throughout the manual by the following symbols. Be sure to read the descriptions shown with each symbol.

 WARNING	This symbol indicates that a danger of possible serious injury or death exists if the associated instructions are not followed properly.
 WARNING	This symbol indicates that a danger of possible serious injury or death caused by electric shock exists if the associated instructions are not followed properly.
 CAUTION	This symbol indicates that a danger of possible harm to people or physical damage to equipment and facilities exists if the associated instructions are not followed properly.

## 1.2 Design and Installation Safety

Only trained personnel should design and install the robot system. Trained personnel are defined as those who have taken robot system training and maintenance training classes held by the manufacturer, dealer, or local representative company, or those who understand the manuals thoroughly and have the same knowledge and skill level as those who have completed the training courses.

To ensure safety, a safeguard must be installed for the robot system. For details on the safeguard, refer to the Installation and Design Precautions in the Safety chapter of the EPSON RC+ User's Guide.

The following items are safety precautions for design personnel:

 WARNING	<ul style="list-style-type: none"> <li>■ Personnel who design and/or construct the robot system with this product must read the <i>Safety</i> chapter in the <i>EPSON RC+ User's Guide</i> to understand the safety requirements before designing and/or constructing the robot system. Designing and/or constructing the robot system without understanding the safety requirements is extremely hazardous, may result in serious bodily injury and/or severe equipment damage to the robot system, and may cause serious safety problems.</li> <li>■ The robot system must be used within the environmental conditions described in their respective manuals. This product has been designed and manufactured strictly for use in a normal indoor environment. Using the product in an environment that exceeds the specified environmental conditions may not only shorten the life cycle of the product but may also cause serious safety problems.</li> </ul>
--	--



- The robot system must be used within the installation requirements described in the manuals. Using the robot system outside of the installation requirements may not only shorten the life cycle of the product but also cause serious safety problems.

Further precautions for installation are mentioned in the chapter Setup & Operation: 3. Environments and Installation. Please read this chapter carefully to understand safe installation procedures before installing the robots and robotic equipment.

### 1.2.1 Strength of the Ball Screw Spline

If a load exceeding the allowable value is applied to the ball screw spline, it may not work properly due to deformation or breakage of the shaft. If the ball screw spline is applied the load exceeding the allowable value, it is necessary to replace the ball screw spline unit. The allowable loads differ depending on distance where the load is applied to.

For calculating the allowable load, see the calculation formula below.

[Allowable bending moment]

$$T3: M=13,000 \text{ N mm}$$

$$T6: M=27,000 \text{ N mm}$$

Example: If 100 N load is applied  
at 200 mm from  
the end of the spline nut

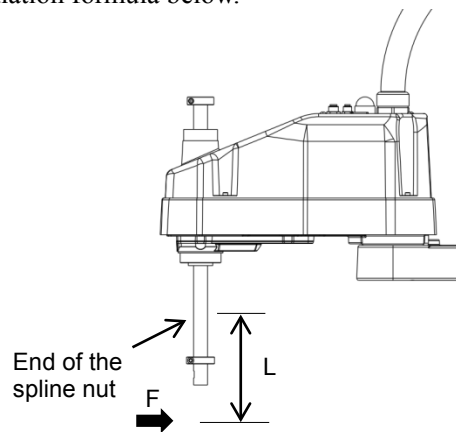

[Moment]

$$M=F \cdot L = 200 \cdot 100 = 20,000 \text{ N mm}$$



## 1.3 Operation Safety

The following items are safety precautions for qualified Operator personnel:

 <p>WARNING</p>	<ul style="list-style-type: none"> <li>■ Please carefully read the 1.3 <i>Safety-related Requirements</i> in the <i>Safety</i> chapter of the <i>Safety and Installation</i> manual before operating the robot system. Operating the robot system without understanding the safety requirements is extremely hazardous and may result in serious bodily injury and/or severe equipment damage to the robot system.</li> <li>■ Do not enter the operating area of the Manipulator while the power to the robot system is turned ON. Entering the operating area with the power ON is extremely hazardous and may cause serious safety problems as the Manipulator may move even if it seems to be stopped.</li> <li>■ Before operating the robot system, make sure that no one is inside the safeguarded area. The robot system can be operated in the mode for teaching even when someone is inside the safeguarded area. The motion of the Manipulator is always in restricted (low speed and low power) status to secure the safety of an operator. However, operating the robot system while someone is inside the safeguarded area is extremely hazardous and may result in serious safety problems in case that the Manipulator moves unexpectedly.</li> <li>■ Immediately press the Emergency Stop switch whenever the Manipulator moves abnormally while the robot system is operated. Continuing the operation while the Manipulator moves abnormally is extremely hazardous and may result in serious bodily injury and/or severe equipment damage to the robot system.</li> </ul>
 <p>WARNING</p>	<ul style="list-style-type: none"> <li>■ To shut off power to the robot system, disconnect the power plug from the power source. Be sure to connect the AC power cable to a power receptacle. DO NOT connect it directly to a factory power source.</li> <li>■ Before performing any replacement procedure, turn OFF the Controller and related equipment, and then disconnect the power plug from the power source. Performing any replacement procedure with the power ON is extremely hazardous and may result in electric shock and/or malfunction of the robot system.</li> <li>■ Do not connect or disconnect the motor connectors while the power to the robot system is turned ON. Connecting or disconnecting the motor connectors with the power ON is extremely hazardous and may result in serious bodily injury as the Manipulator may move abnormally, and also may result in electric shock and/or malfunction of the robot system.</li> </ul>



CAUTION

- Whenever possible, only one person should operate the robot system. If it is necessary to operate the robot system with more than one person, ensure that all people involved communicate with each other as to what they are doing and take all necessary safety precautions.
- Joint #1, #2, and #4:  
If the joints are operated repeatedly with the operating angle less than 5 degrees, they may get damaged early because the bearings are likely to cause oil film shortage in such situation. To prevent early breakdown, move the joints larger than 50 degrees for about five to ten times a day.  
  
Joint #3:  
If the up-and-down motion of the hand is less than 10 mm, move the joint a half of the maximum stroke for five to ten times a day.
- Oscillation (resonance) may occur continuously in low speed Manipulator motion (Speed: approx. 5 to 20%) depending on combination of Arm orientation and end effector load. Oscillation arises from natural oscillation frequency of the Arm and can be controlled by following measures.
  - Changing Manipulator speed
  - Changing the teach points
  - Changing the end effector load
- Oscillation (resonance) may occur continuously in low speed Manipulator motion (Speed: approx. 5 to 20%) depending on combination of Arm orientation and end effector load. Oscillation arises from natural oscillation frequency of the Arm and can be controlled by following measures.
- Manipulator may be heated due to motor heat etc. Do not touch the Manipulator until temperature falls. After confirming that the temperature of the Manipulator falls and is not hot when you touch it. Then perform teaching or maintenance.

## 1.4 Emergency Stop

If the Manipulator moves abnormally during operation, immediately press the Emergency Stop switch. Pressing the Emergency Stop switch immediately changes the manipulator to deceleration motion and stops it at the maximum deceleration speed.

However, avoid pressing the Emergency Stop switch unnecessarily while the Manipulator is running normally. Pressing the Emergency Stop switch locks the brake and it may cause wear on the friction plate of the brake, resulting in the short life of the brake.

Normal brake life cycle: About 2 years (when the brakes are used 100 times/day)

To place the system in emergency mode during normal operation, press the Emergency Stop switch when the Manipulator is not moving.

Refer to the *Setup & Operation: II. EMERGENCY* for instructions on how to wire the Emergency Stop switch circuit.

Do not turn OFF the power while the Manipulator is operating.

If you attempt to stop the Manipulator in emergency situations such as “Safeguard Open”, make sure to stop the Manipulator using the Emergency Stop switch.

If the Manipulator is stopped by turning OFF the power while it is operating, following problems may occur.

Reduction of the life and damage of the reduction gear unit

Position gap at the joints

In addition, if the manipulator was forced to be turned OFF by blackouts and the like while the Manipulator is operating, make sure to check the following points after power restoration.

Whether or not the reduction gear is damaged

Whether or not the joints are in their proper positions

If there is a position gap, perform calibration by referring to the *Maintenance 16. Calibration* in this manual. Also, the same troubles may occur if an error occurs and the Manipulator stops in emergency during the operation. Check the Manipulator condition and perform calibration if necessary.

Before using the Emergency Stop switch, be aware of the following.

- The Emergency Stop (E-STOP) switch should be used to stop the Manipulator only in case of emergencies.
- To stop the Manipulator operating the program except in emergency, use Pause (halt) or STOP (program stop) commands  
Pause and STOP commands do not turn OFF the motors. Therefore, the brake does not function.
- For the Safeguard system, do not use the circuit for E-STOP.

For details of the Safeguard system, refer to the following manuals.

EPSON RC+ User's Guide

2. Safety - Installation and Design Precautions - Safeguard System

Safety and Installation

2.6 Connection to EMERGENCY Connector

To check brake problems, refer to the following manuals.

Manipulator Manual *Maintenance*

2.1.2 *Inspection Point - Inspection While the Power is ON*

(Manipulator is operating)

Safety and Installation

5.1.1 Manipulator

- *Inspection While the Power is ON (Manipulator is operating)*

**Free running distance in emergency**

The operating Manipulator cannot stop immediately after the Emergency Stop switch is pressed.

The free running time/angle/distance of the Manipulator are shown below. However, remember that the values vary depending on following conditions.

Weight of the end effector Weight of work piece Operating pose

Weight Speed Accel etc.

Conditions for Measurement	T3-401S	T6-602S
Accel Setting	100	100
Speed Setting	100	100
Load [kg]	3	6
Weight Setting	3	6

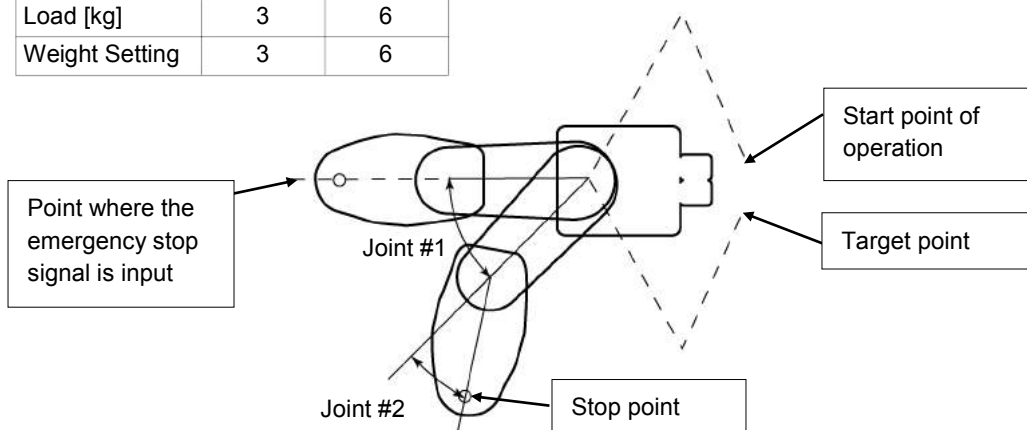

		T3-401S	T6-602S
Free running time	Joint #1 + Joint #2 [sec.]	0.5	0.4
	Joint #3 [sec.]	0.2	0.2
Free running angle	Joint #1 [deg.]	50	60
	Joint #2 [deg.]	50	30
	Joint #1 + Joint #2 [deg.]	100	90
Free running distance	Joint #3 [mm]	20	40



## 1.5 Emergency Movement Without Drive Power

When the system is placed in emergency mode, push the arm or joint of the Manipulator by hand as shown below:

- |          |  |
|----------|--|
| Arm #1   | Push the arm by hand.  |
| Arm #2   | Push the arm by hand.  |
| Joint #3 | The joint cannot be moved up/down by hand until the solenoid brake applied to the joint has been released. Move the joint up/down while pressing the brake release switch. |
| Joint #4 | Rotate the shaft by hand.  |

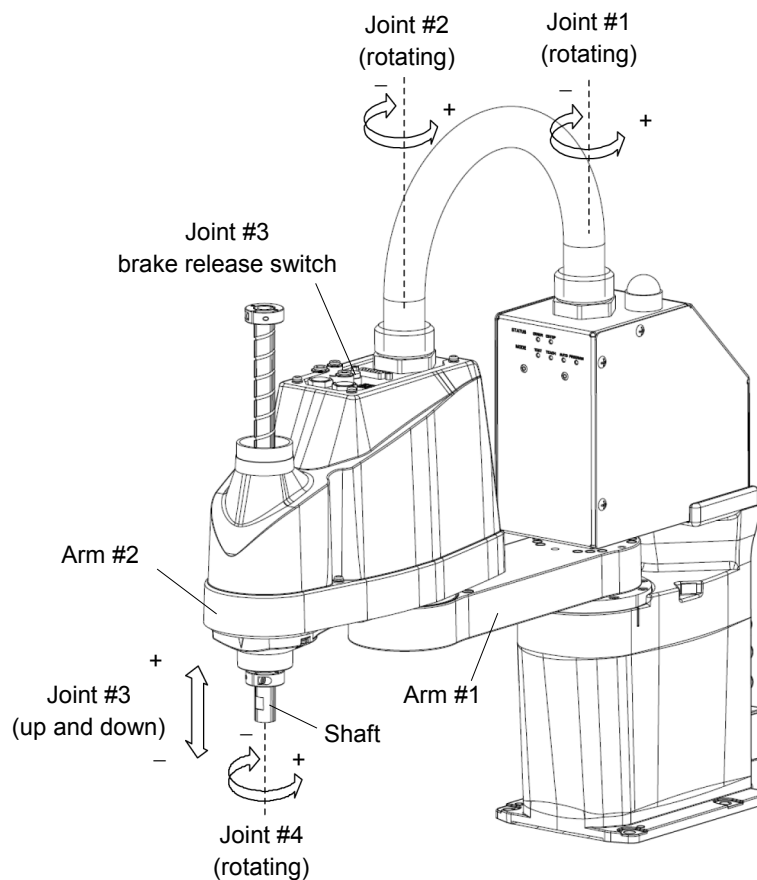

(Illustration: T3-401S)

**NOTE**  The brake release switch affects only Joint #3. When the brake release switch is pressed in emergency mode, the brake for Joint #3 is released. Be careful of the shaft while the brake release switch is pressed because the shaft may be lowered by the weight of an end effector.

**NOTE**  When the following errors are occurred, the manipulator brake is not released even if pressing the brake release switch. Check the cable connections and remove the error causes. Then, apply the power again and release the brake.

Errors: 1552, 2118, 4003, 4004, 4009, 4100, 4101, 4103, 4187, 4188, 4189, 4191, 4192, 4233, 4240, 4285-4292, 9633, 9640, 9691, 9685-9692

## 1.6 ACCELS Setting for CP Motions

To make the Manipulator move in CP motion, see the following and set ACCELS properly according to the tip load and the Z-axis height.



Improper setting may cause following problems.  
 - Decline in the life and damage of the ball screw spline

Set the ACCELS as follows depending on the Z axis height.

ACCELS setting values by Z-axis height and tip load

T3

Z axis height (mm)	Tip load		
	1kg or less	2kg or less	3kg or less
0 > Z >= - 50	25000 or less	25000 or less	22500 or less
- 50 > Z >= - 100		22500 or less	15000 or less
- 100 > Z >= - 150		17500 or less	10000 or less

T6

Z axis height (mm)	Tip load		
	2kg or less	4kg or less	6kg or less
0 > Z >= - 50	25000 or less	25000 or less	25000 or less
- 50 > Z >= - 100			15000 or less
- 100 > Z >= - 150		17500 or less	12500 or less
- 150 > Z >= - 200		15000 or less	10000 or less

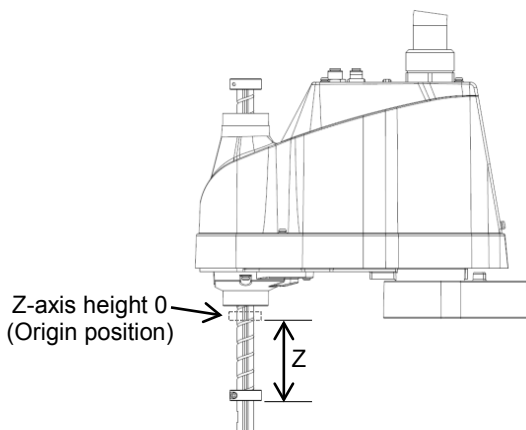

If the Manipulator is operated in CP motion with the wrong set values, make sure to check the following points.

- Whether or not the ball screw spline shaft is deformed or bent





## 1.7 Labels

The Manipulator has the following warning labels.

The warning labels are attached around the locations where specific dangers exist.

Be sure to comply with descriptions and warnings on the labels to operate and maintain the Manipulator safely.

Do not tear, damage, or remove the warning labels. Use meticulous care when handling those parts or units to which the following warning labels are attached as well as the nearby areas.

Location	Warning Label	NOTE
A		Before loosening the base mounting screws, hold the arm and secure it tightly with a band to prevent hands or fingers from being caught in the Manipulator.
B		Do not enter the operation area while the Manipulator is moving. The robot arm may collide against the operator. This is extremely hazardous and may result in serious safety problems.
C		Hazardous voltage exists while the Manipulator is ON. To avoid electric shock, do not touch any internal electric parts.
D		You can catch your hand or fingers between the shaft and cover when bringing your hand close to moving parts.
E		Signature label S/N (Serial Number) Label

T3

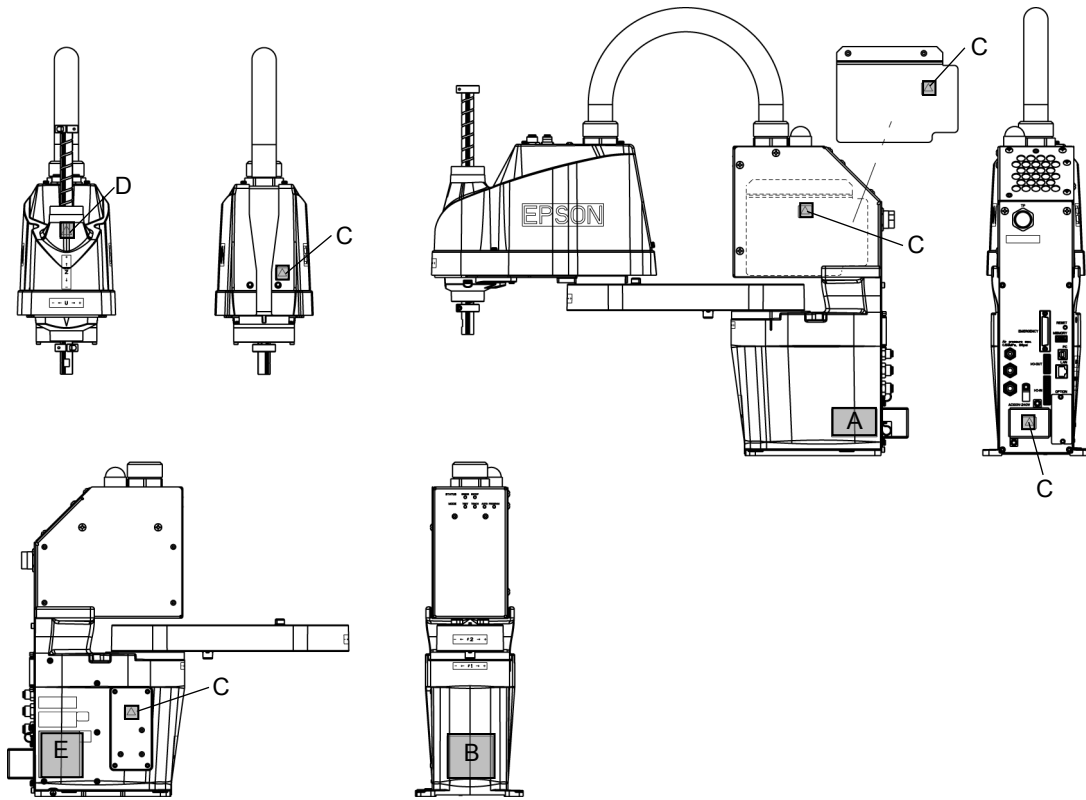

T6

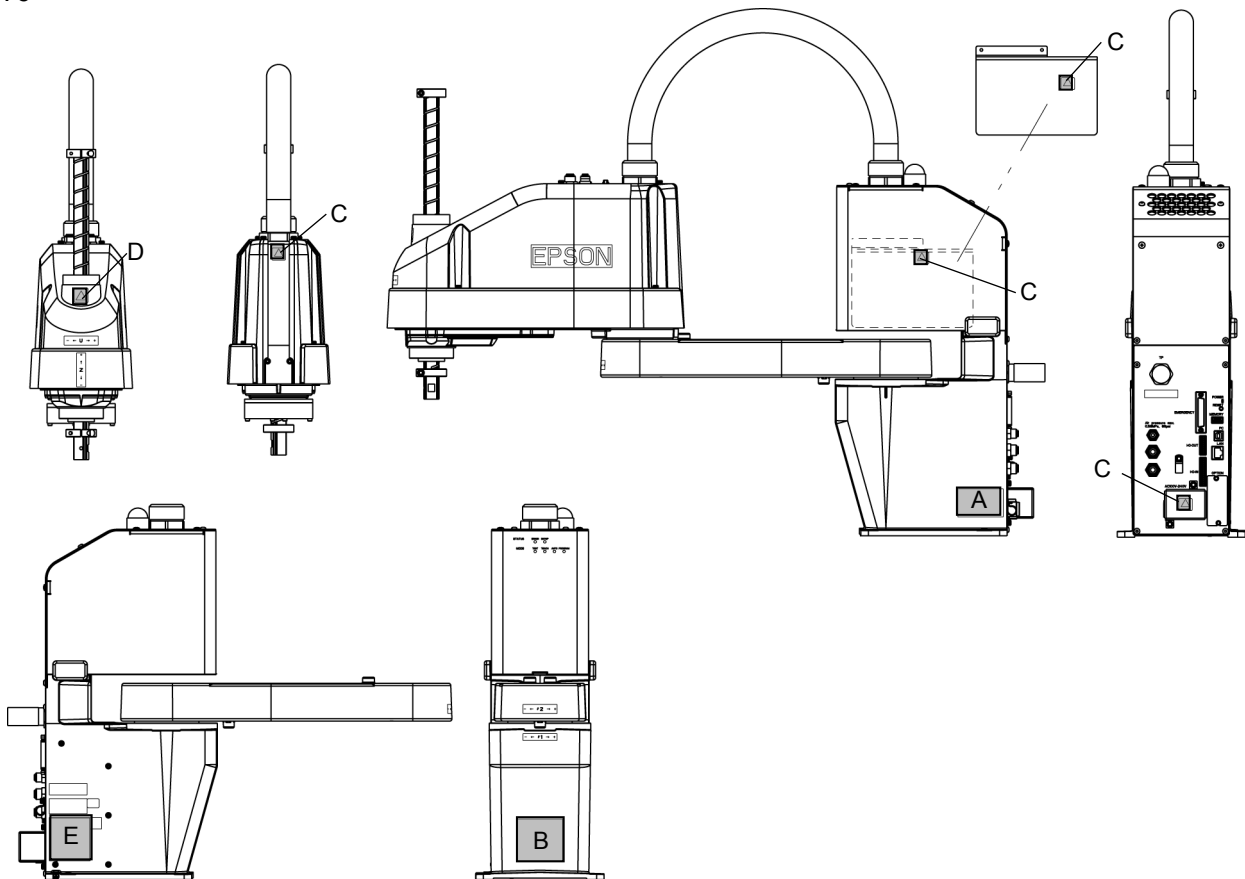

## 2. Specifications

### 2.1 Features of T series Manipulators

The T series Manipulators are controller integrated manipulators.

The features of the T series Manipulators are as follows:

For Device design and tooling

- There is no external controller

The controller is integrated with the robot.

No installation space required for an external controller.

No design is required for external controller installation or tooling.

- No robot to controller external cables

There are no external cables required between the robot and controller.

- Hand (end effector) can be controlled directly by Hand I/O and DC24V for hand

Wiring between controller and manipulator end effector is not necessary.

- Duct vibration reducing structure

Easy to route external cables.

For Maintenance

- There are no motor unit batteries for the robot

No longer necessary to connect external devices for battery replacement.

- Easy to replace the manipulator

- Air Cooling Fan-less

No air cooling fan maintenance is required.

Others

- Power-saving

T3: Approx. 1/4 of LS3/RC90

T6: Approx. 1/3 of LS6/RC90

## 2.2 Model Number

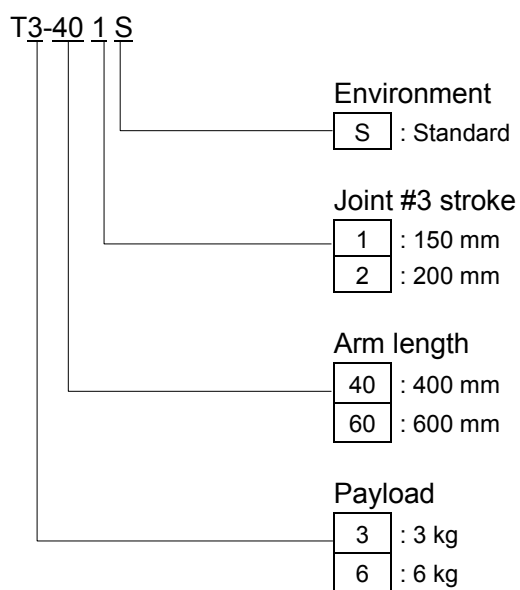

For details on the specifications, refer to *Setup & Operation: 2.6 Specifications*.

## 2.3 Part Names

### 2.3.1 T3

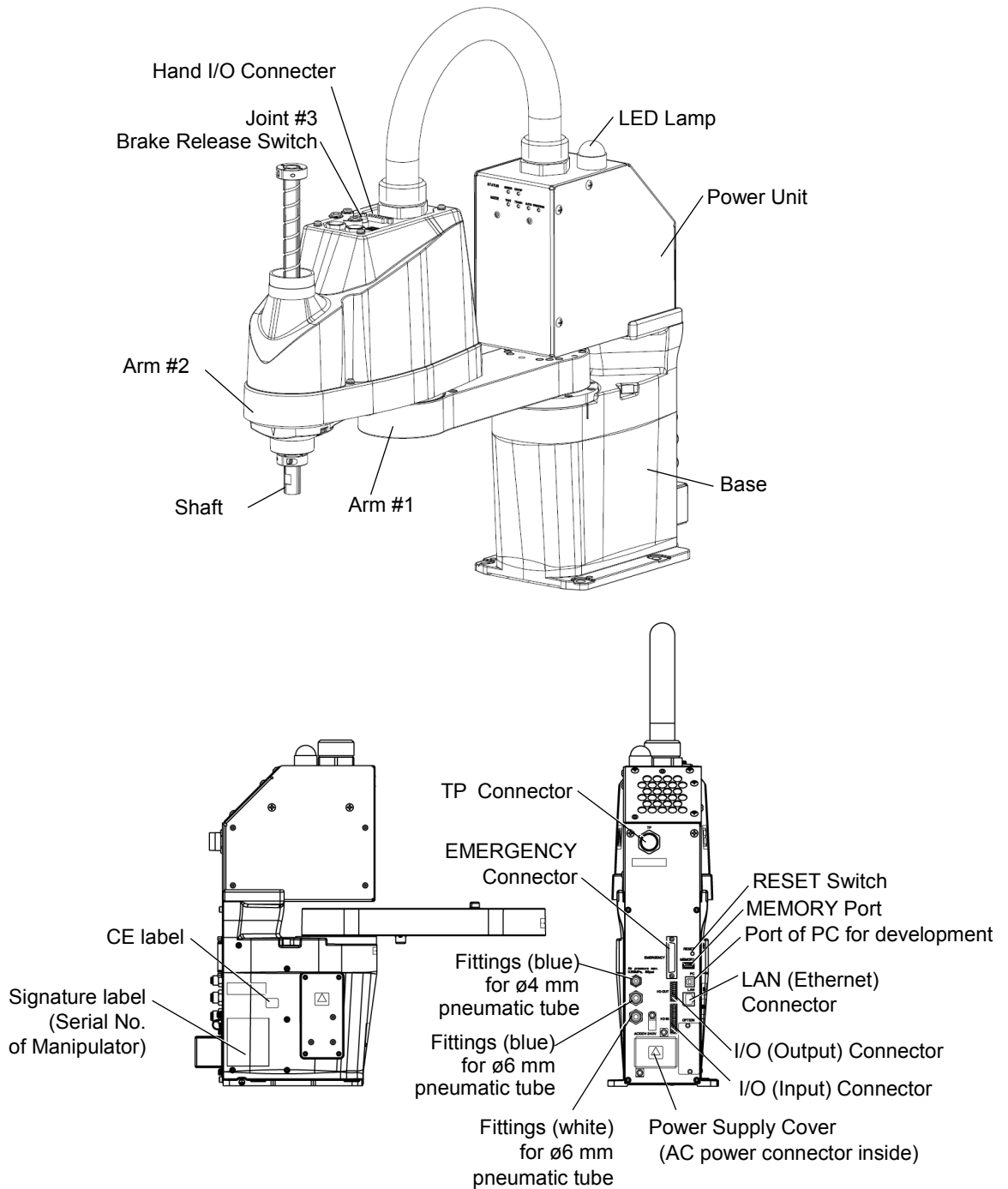

- NOTE**
- The brake release switch affects only Joint #3. When the brake release switch is pressed in emergency mode, the brake for Joint #3 is released.
  - While the LED lamp is on, the current is being applied to the manipulator. Performing any work with the power ON is extremely hazardous and it may result in electric shock and/or improper function of the robot system. Make sure to turn OFF the Manipulator power before the maintenance work.

2.3.2 T6

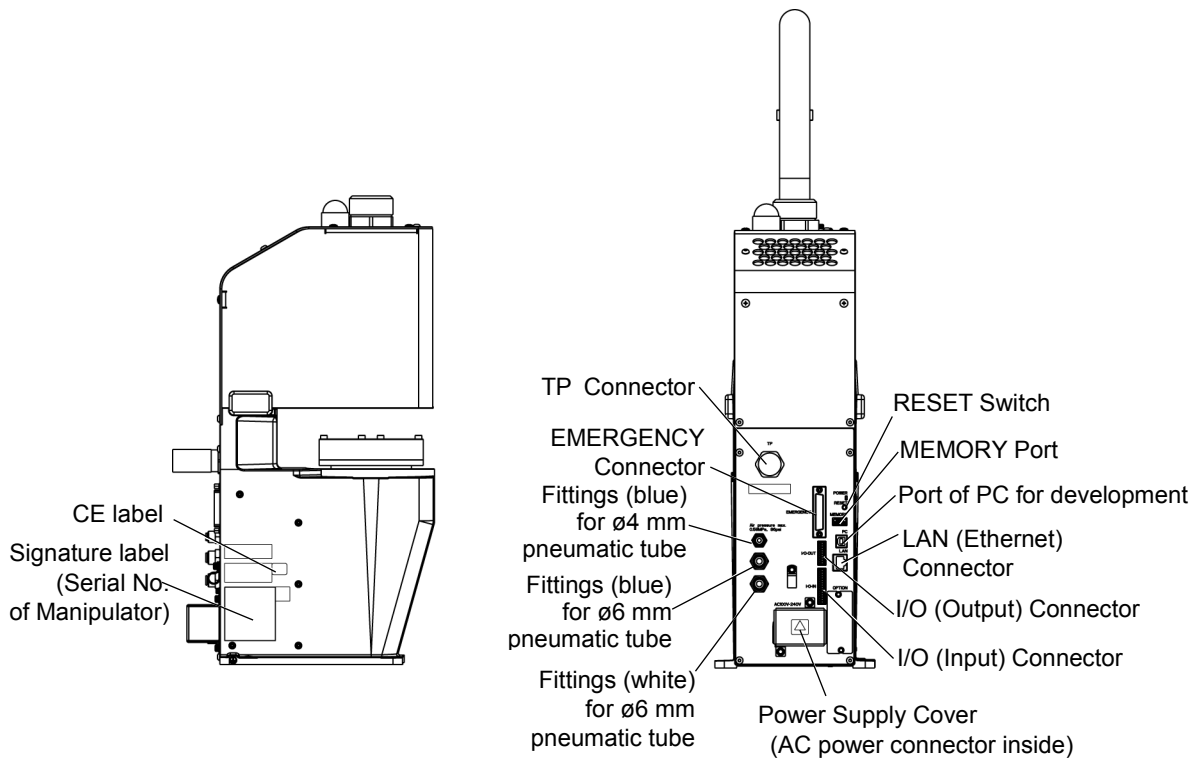
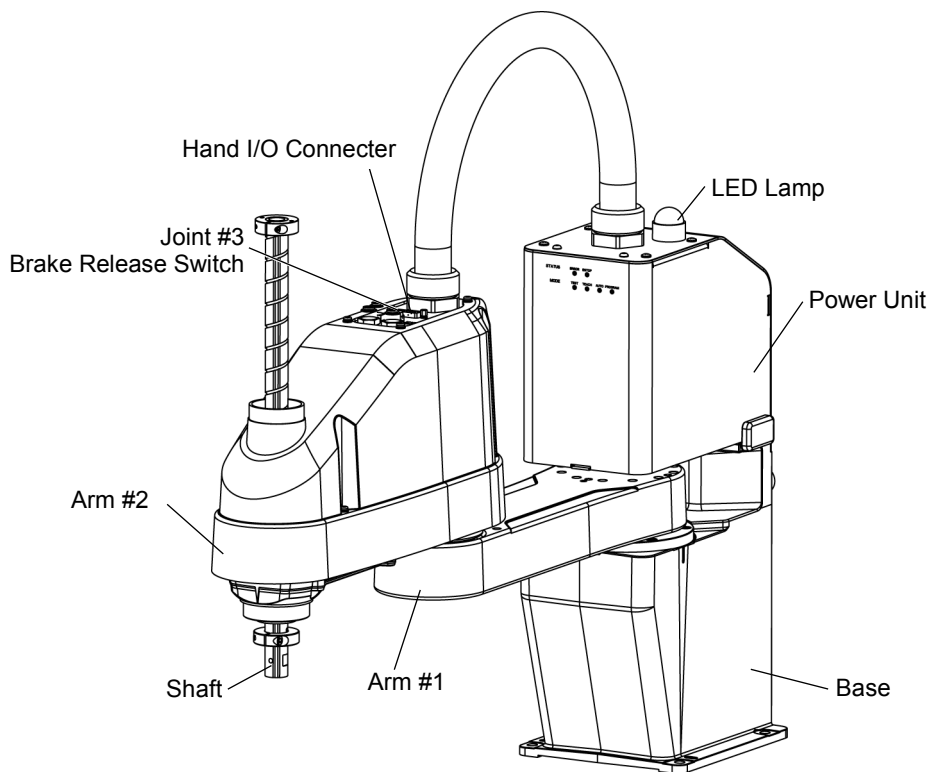

- NOTE** - The brake release switch affects only Joint #3. When the brake release switch is pressed in emergency mode, the brake for Joint #3 is released.
-  - While the LED lamp is ON, current is applied to the manipulator. Performing any work with the power ON is extremely hazardous and it may result in electric shock and/or improper function of the robot system. Make sure to turn OFF the Manipulator power before maintenance work.



2.4 Outer Dimensions

2.4.1 T3

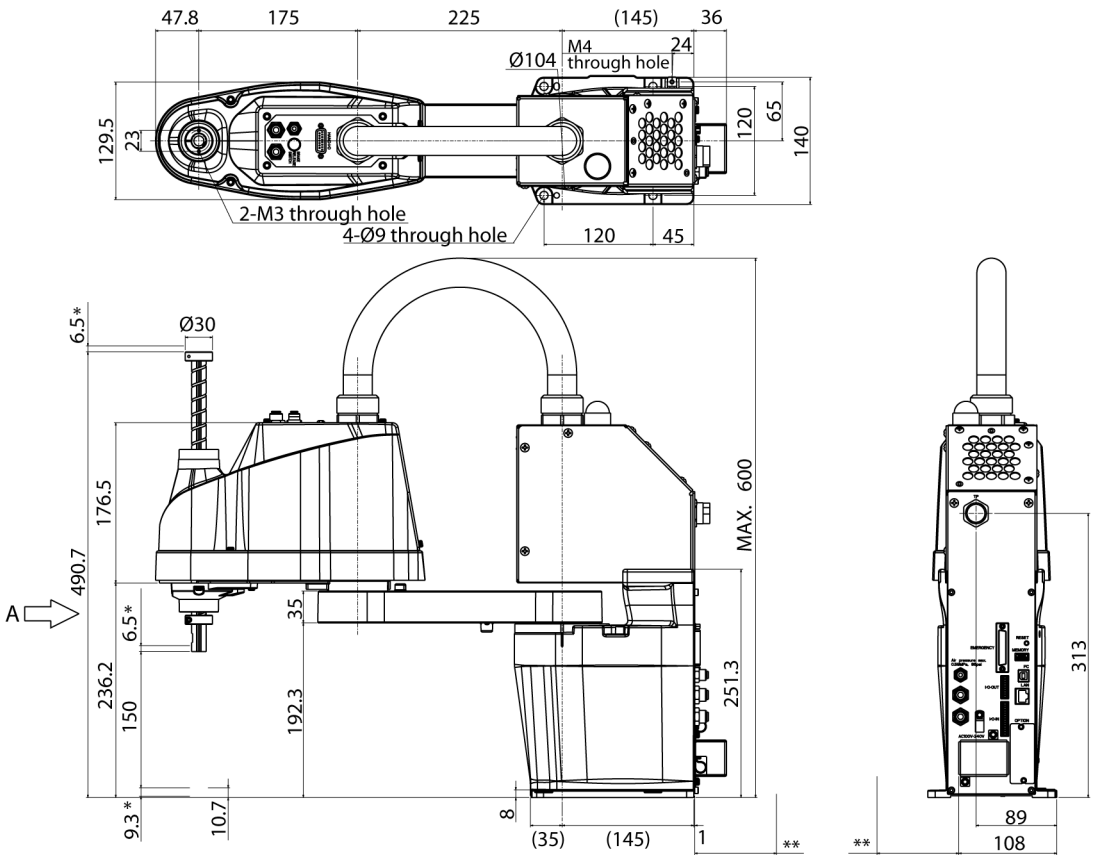

\* indicates the stroke margin by mechanical stop.

\*\* 90 or more (Space for cables)

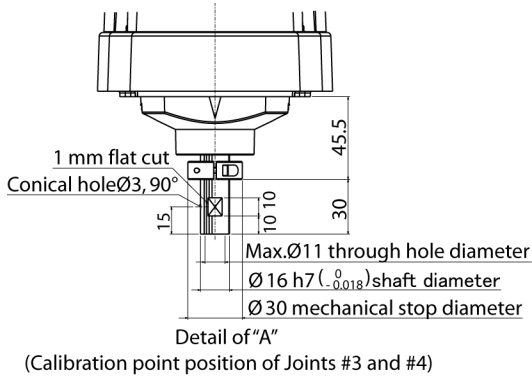
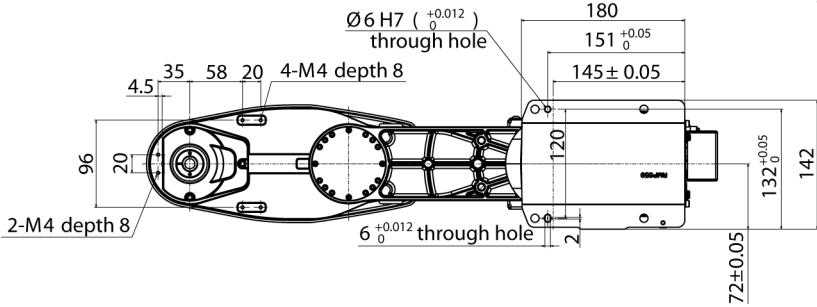

2.4.2 T6

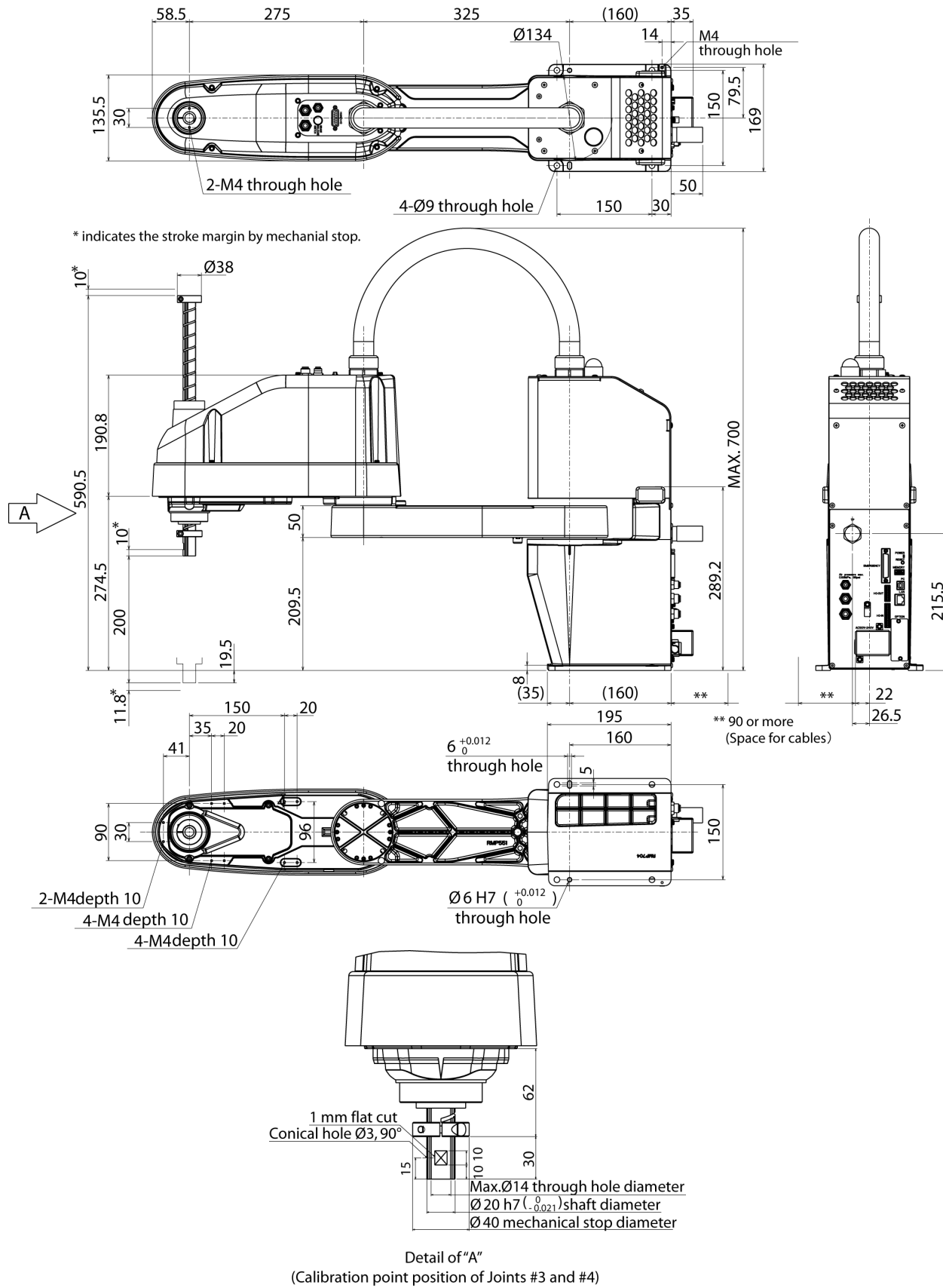

## 2.5 System Example

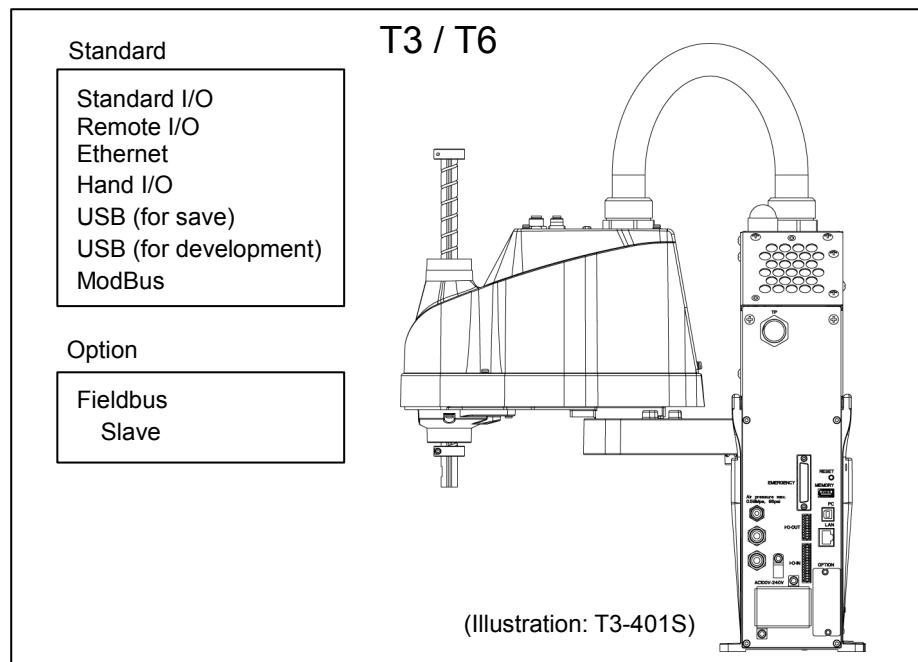

USB 2.0  
or  
Ethernet

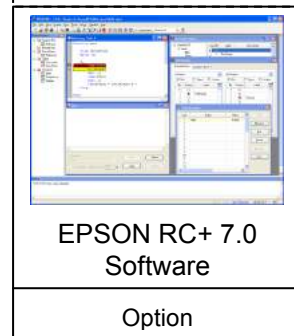
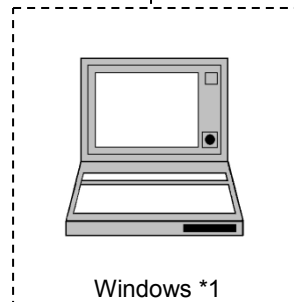

\*2

Option: Teaching Pendant

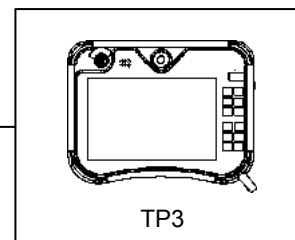
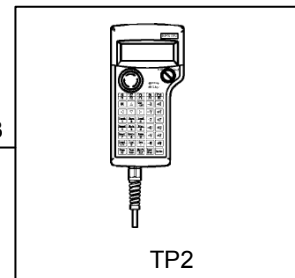

- \*1 EPSON RC+ 7.0 supports the following OS  
Windows 7 Professional Service Pack 1  
Windows 8.1 Pro (EPSON RC+7.0 Ver.7.1.0 or later)  
Windows 10 Pro (EPSON RC+7.0 Ver.7.2.0 or later)
- \*2 Either teaching pendant is available.
- \*3 When connecting to T3 / T6, specified convert cable is necessary.

## 2.6 Specifications

Item		T3-401S	T6-602S
Arm length	Arm #1, #2	400 mm	600 mm
	Arm #1	225 mm	325 mm
	Arm #2	175 mm	175 mm
Weight (cables not included)		16 kg: 35 lb.	22 kg: 49 lb
Driving method	All joints	AC servo motor	
Max. operating speed*1	Joints #1, #2	3700 mm/s	4180 mm/s
	Joint #3	1000 mm/s	1000 mm/s
	Joint #4	2600 deg/s	1800 deg/s
Repeatability	Joints #1, #2	± 0.02 mm	± 0.04 mm
	Joint #3	± 0.02 mm	± 0.02 mm
	Joint #4	± 0.02 deg	± 0.02 deg
Max. motion range	Joint #1	± 132 deg	± 132 deg
	Joint #2	± 141 deg	± 150 deg
	Joint #3	150 mm	200 mm
	Joint #4	± 360 deg	± 360 deg
Max. pulse range	Joint #1	- 95574 ~ 505174	- 152918 ~ 808278
	Joint #2	± 320854	± 341334
	Joint #3	-187734 ~ 0	- 245760 ~ 0
	Joint #4	± 71760	± 245760
Resolution	Joint #1	0.000439 deg/pulse	0.000275deg/pulse
	Joint #2	0.000439 deg/pulse	0.000439 deg/pulse
	Joint #3	0.000799 mm/pulse	0.000814 mm/pulse
	Joint #4	0.005017deg/pulse	0.01465deg/pulse
Motor energy consumption	Joint #1	200 W	300 W
	Joint #2	100 W	200 W
	Joint #3	100 W	
	Joint #4	100 W	
Payload (Load)	Rated	1 kg	2 kg
	Max.	3 kg	6 kg
Joint #4 allowable moment of inertia*2	Rated	0.003 kg·m <sup>2</sup>	0.01 kg·m <sup>2</sup>
	Max.	0.01 kg·m <sup>2</sup>	0.08 kg·m <sup>2</sup>
Hand	Shaft diameter	ø 16 mm	ø 20 mm
	Through hole	ø 11 mm	ø 14 mm
Joint #3 down force		83 N	
Hand I/O Connector		15 pin: D-sub	
Installed pneumatic tube for customer use		2 pneumatic tubes (ø6 mm): 0.59 MPa (6 kgf/cm <sup>2</sup> : 86 psi)	
		1 pneumatic tubes (ø4 mm): 0.59 MPa (6 kgf/cm <sup>2</sup> : 86 psi)	
Mounting hole		120 × 120 mm	150 × 150 mm
		4-M8	
Environmental requirements	Ambient Temp.	5 to 40 degrees C (with minimum temperature variation)	
	Ambient relative humidity	20 to 80% (no condensation)	
Noise level *3		L <sub>Aeq</sub> = 80 dB (A) or less	

Item		T3-401S	T6-602S
Assignable Value ( ) Default values	Speed	1 ~ (5) ~ 100	1 ~ (5) ~ 100
	Accel *4	1 ~ (10) ~ 120	1 ~ (10) ~ 120
	SpeedS	0.1 ~ (50) ~ 2000	0.1 ~ (40) ~ 2000
	AccelS	0.1 ~ (200) ~ 10000	0.1 ~ (200) ~ 10000
	Fine	0 ~ (1250) ~ 65000	0 ~ (1250) ~ 65000
	Weight	0,175 ~ (1,175) ~ 3,175	0,275 ~ (2,275) ~ 6,275
Motion Control	Development Environment	EPSON RC+ 7.0	
	Programming Language	SPEL+ (multi-tasking robot language)	
	Joint Control	Standard 4 joints simultaneous control Digital AC servo control	
	Positioning Control	PTP (Point-To-Point control) CP (Continuous Path control)	
	Speed Control	PTP motion : Programmable in the range of 1 to 100% CP motion : Programmable (Actual value to be manually entered.)	
	Acceleration/Deceleration Control	PTP motion : Programmable in the range of 1 to 100%; Automatic CP motion : Programmable (Actual value to be manually entered.)	
External Interface	EMERGENCY		EMERGENCY STOP: Redundant (Category 3) Supported for internal/external power supply Safeguard System: Redundant (Category 3) Supported for external power supply
	I/O	Standard I/O (Rear side of Manipulator)	Input: 18 points Output: 12 points Non-polar, Supported for both Sink and Source
		Remote I/O (Remote functions are applied to Standard I/O)	Input: 8 points Program, 3 points Start, Stop, Pause, Continue, Reset Output: 8 points Ready, Running, Paused, ErrorEStopOn, SafeguardOn, SError, Warning
		Hand I/O (Upper side of Arm #2)	Input: 6 points Output: 4 points Non-polar, Supported for both Sink and Source Power supply: available up to 24V 500mA
		Power: 24V Max. 500mA	Power: 24V Max. 700mA
External Interface	Field bus Slave (Option)	Input: 256 points Output: 256 points Enable to add only one more module	
	TP Connection Port	Supported for teach pendant (Option: TP2, TP3)	
	PC Connection Port	USB B connector Supported for USB 2.0 High Speed / Full Speed	
	USB Memory Connection Port	USB A connector Supported for USB 2.0 High Speed / Full Speed	
	Ethernet Port	Supported for 10/100 Mbps Available up to 8 ports	
	RESET Switch	Enable to use for reset of system	

Item		T3-401S	T6-602S
Display	Mode Display LED	TEACH, AUTO, PROGRAM, TestMode, Error, E-STOP	
Controller Status Save		Save to USB memory Save in RC+ (PC)	
Voltage		100 V to 240 VAC	
Phase		Single phase	
Frequency		50 / 60 Hz	
Momentary Power Interrupt		Less than 10 ms	
Power Consumption		660 VA	1,200 VA
Peak Current (When AC power is turned ON)		Max. 30A (Less than 2 ms.)	Max. 60A (Less than 2 ms.)
Leak Current		Max. 10 mA	
Ground Resistance		Less than 100Ω	
Safety standard		CE Mark EMC Directive, Machinery Directive ANSI/RIA R15.06-2012 NFPA 79 (2007 Edition)	

- \*1: In the case of PTP command. Maximum operating speed for CP command is 2000 mm/s on horizontal plane.
- \*2: In the case where the center of gravity is at the center of Joint #4. If the center of gravity is not at the center of Joint #4, set the parameter using Inertia command.
- \*3: Conditions of Manipulator during measurement as follows:  
 Operating conditions : Under rated load, 4-joints simultaneous motion, maximum speed, maximum acceleration, and duty 50%.  
 Measurement point : Rear of the Manipulator, 1000 mm apart from the motion range, 50 mm above the base-installed surface.
- \*4: In general use, Accel setting 100 is the optimum setting that maintains the balance of acceleration and vibration when positioning. Although values larger than 100 can be set to Accel, it is recommended to minimize the use of large values to necessary motions since operating the manipulator continuously with the large Accel setting may shorten the product life remarkably.

## 2.7 How to Set the Model

The Manipulator model for your system has been set before shipment from the factory. It is normally not required to change the model when you receive your system.

 <p>CAUTION</p>	<ul style="list-style-type: none"><li>■ When you need to change the setting of the Manipulator model, be sure to set the Manipulator model properly. Improper setting of the Manipulator model may result in abnormal or no operation of the Manipulator and/or cause safety problems.</li></ul>
--	--

**NOTE**  If the custom specifications number (MT\*\*\*) is described on MODEL of the signature label (S/N label), the Manipulator has custom specifications. The custom specifications may require a different configuration procedure; check the custom specifications number (MT\*\*\*) and contact us when necessary.

The Manipulator model can be set from software.

Refer to the chapter *Robot Configuration* in the *EPSON RC+ User's Guide*.

## 3. Environments and Installation

### 3.1 Environmental Conditions

A suitable environment is necessary for the robot system to function properly and safely. Be sure to install the robot system in an environment that meets the following conditions:

Item	Conditions
Ambient temperature	5 to 40°C (with minimum temperature variation)
Ambient relative humidity	20 to 80% (with no condensation)
First transient burst noise	2 kV or less
Electrostatic noise	4 kV or less
Environment	<ul style="list-style-type: none"> <li>· Install indoors.</li> <li>· Keep away from direct sunlight.</li> <li>· Keep away from dust, oily smoke, salinity, metal powder or other contaminants.</li> <li>· Keep away from flammable or corrosive solvents and gases.</li> <li>· Keep away from water.</li> <li>· Keep away from shocks or vibrations.</li> <li>· Keep away from sources of electric noise.</li> <li>- Keep away from strong electric or magnetic fields.</li> </ul>



Manipulators are not suitable for operation in harsh environments such as painting areas, etc. When using Manipulators in inadequate environments that do not meet the above conditions, please contact us.

#### Special Environmental Conditions

Surface of the Manipulator has general oil resistance. However, if your requirements specify that the Manipulator must withstand certain kinds of oil, please consult your distributor.

Rapid change in temperature and humidity can cause condensation inside the Manipulator. If your requirements specify that the Manipulator handles food, please consult your distributor to check whether the Manipulator will damage the food or not.

The Manipulator cannot be used in corrosive environments where acid or alkaline is used. In a salty environment where the rust is likely to gather, the Manipulator is susceptible to rust.

 WARNING	<ul style="list-style-type: none"> <li>■ Use an earth leakage breaker on the AC power cable of the Manipulator to avoid electric shock and circuit breakdown caused by short circuit.</li> </ul>
-------------	--

 CAUTION	<ul style="list-style-type: none"> <li>■ When cleaning the Manipulator, do not rub it strongly with alcohol or benzene. It may lose luster on the coated face.</li> </ul>
-------------	---



## 3.2 Base Table

A base table for anchoring the Manipulator is not supplied. Please make or obtain the base table for your Manipulator. The shape and size of the base table differs depending on the use of the robot system. For your reference, we list some Manipulator table requirements here.

Base table is necessary for support not only the weight of the manipulator but also dynamic motion when operating at the fastest speed. Provides enough beams to give sufficient strength.

The torque and reaction force produced by the movement of the Manipulator are as follows:

	T3	T6
Max. Reaction torque on the horizontal plate	150 N·m	350 N·m
Max. Horizontal reaction force	500 N	750 N
Max. Vertical reaction force	900 N	1500 N

The threaded holes required for mounting the Manipulator base are M8. Use mounting bolts with specifications conforming to ISO898-1 property class: 10.9 or 12.9. For dimensions, refer to *Setup & Operation: 3.3 Mounting Dimensions*.

The plate for the Manipulator mounting face should be 20 mm thick or more and made of steel to reduce vibration. The surface roughness of the steel plate should be 25  $\mu\text{m}$  or less.

The table must be secured on the floor or wall to prevent it from moving.

The Manipulator must be installed horizontally.

When using a leveler to adjust the height of the base table, use a screw with M16 diameter or more.

If you are passing cables through the holes on the base table, see the figures below.

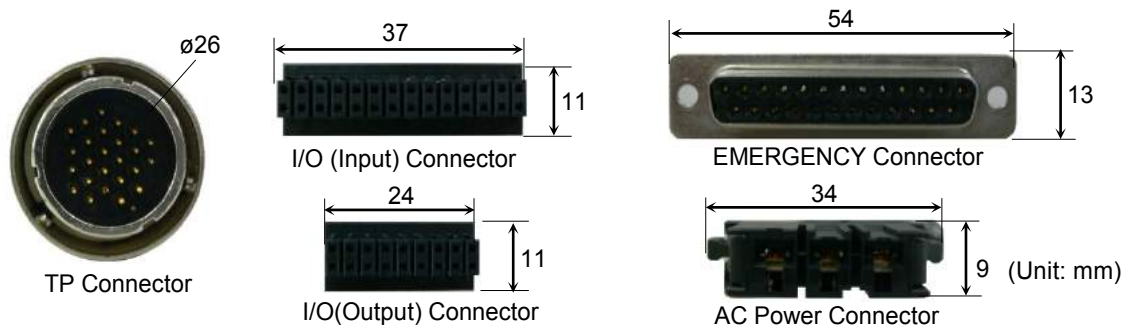

- To ensure safety, a safeguard must be installed for the robot system. For details on the safeguard, refer to the *EPSON RC+ User's Guide*.

### 3.3 Mounting Dimensions

The maximum space described in figures shows that the radius of the end effector is 60 mm or less. If the radius of the end effector exceeds 60 mm, define the radius as the distance to the outer edge of maximum space.

If a camera or solenoid valve extends outside of the arm, set the maximum range including the space that they may reach.

Be sure to allow for the following extra spaces in addition to the space required for mounting the Manipulator and peripheral equipment.

Space for teaching

Space for maintenance and inspection

(Ensure a space to open the covers and plates for maintenance.)

Space for cables

The minimum bend radius of the power cable is 90 mm. When installing the cable, be sure to maintain sufficient distance from obstacles. In addition, leave enough space for other cables so that they are not bent forcibly.

Ensure distance to the safeguard from the maximum motion range is more than 100 mm.

T3

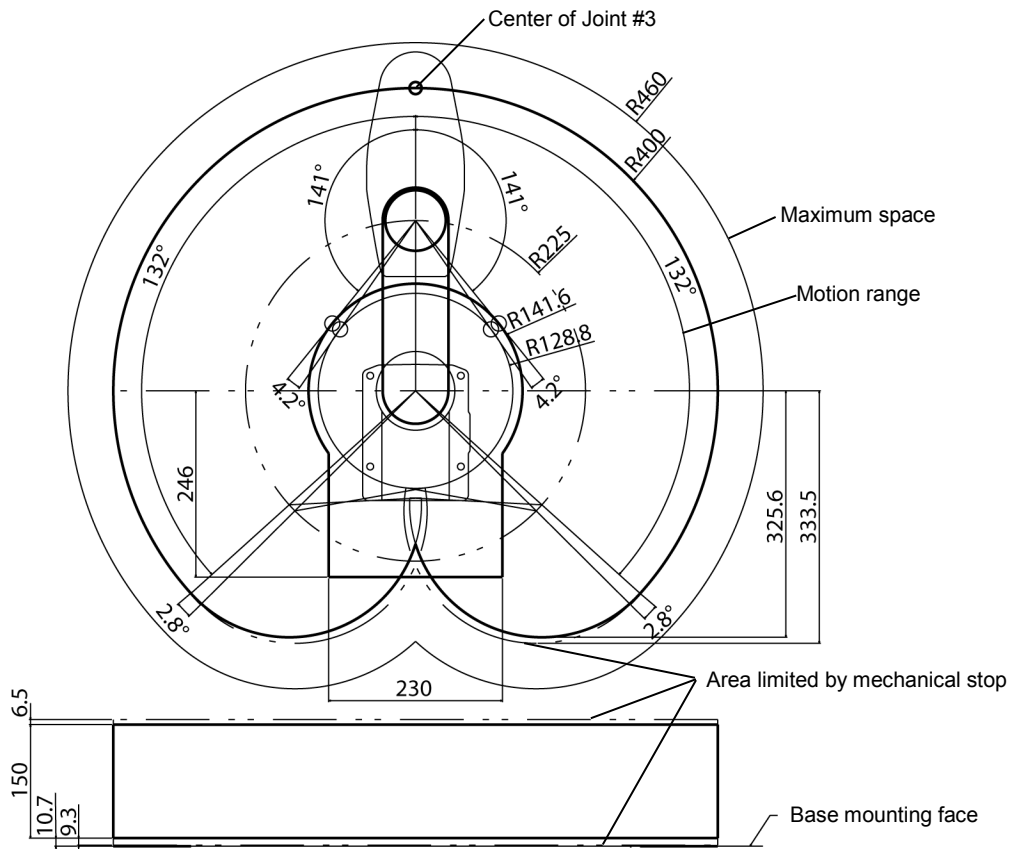

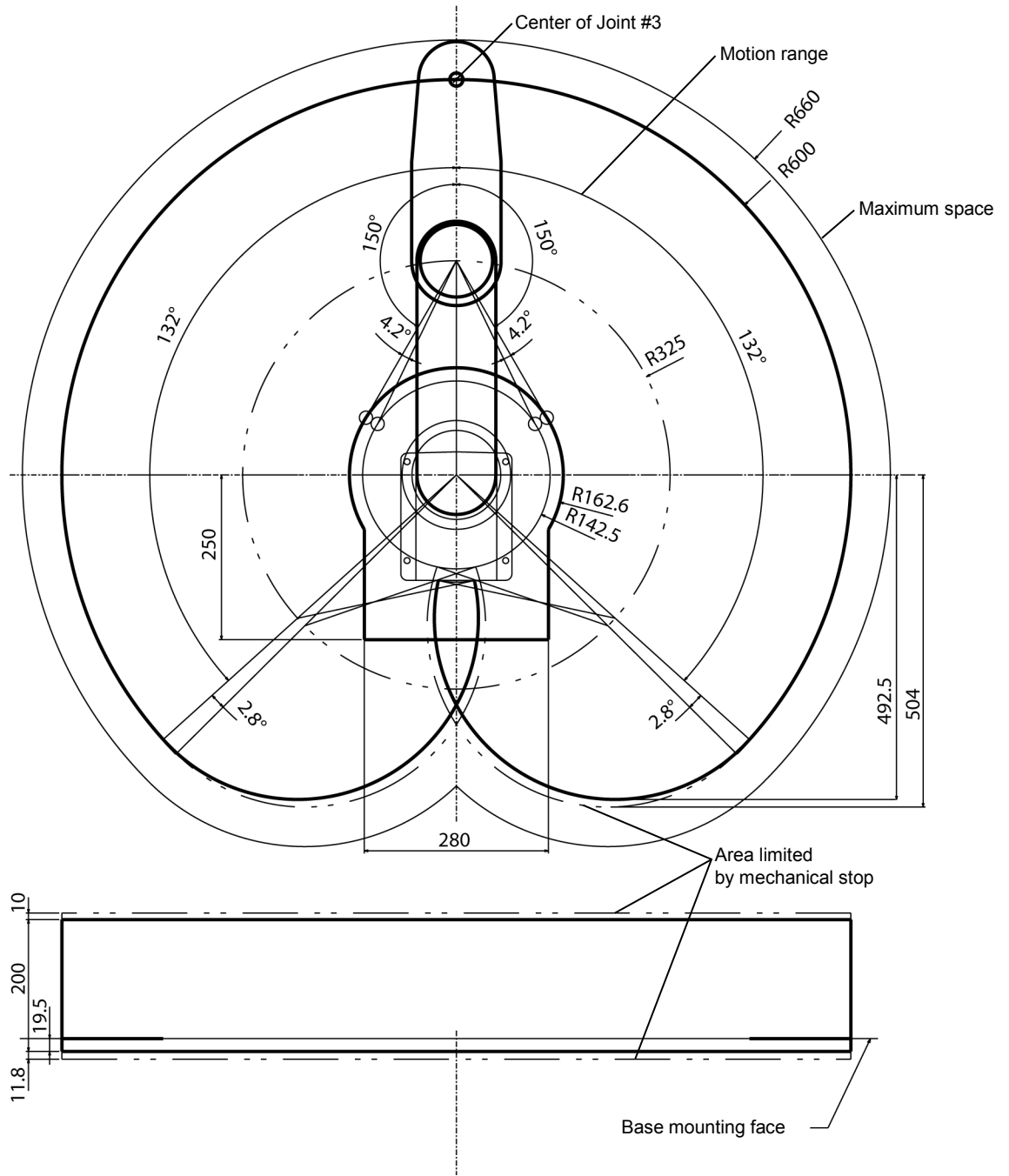

T6



### 3.4 Unpacking and Transportation

THE INSTALLATION SHALL BE PREFORMED BY QUALIFIED INSTALLATION PERSONNEL AND SHOULD CONFORM TO ALL NATIONAL AND LOCAL CODES.

 WARNING	<ul style="list-style-type: none"> <li>Only authorized personnel should perform sling work and operate a crane and a forklift. When these operations are performed by unauthorized personnel, it is extremely hazardous and may result in serious bodily injury and/or severe equipment damage to the robot system.</li> </ul>
--	--

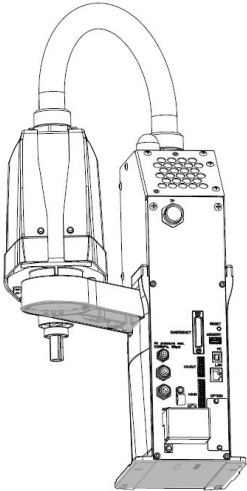
 CAUTION	<ul style="list-style-type: none"> <li>Using a cart or similar equipment, transport the Manipulator in the same manner as it was delivered.</li> <li>After removing the bolts securing the Manipulator to the delivery equipment, the Manipulator can fall. Be careful not to get hands or fingers caught.</li> <li>The arm is secured with a sheet. Leave the sheet secured until you finish the installation so as not to get hands or fingers caught.</li> <li>To carry the Manipulator, have two or more people to work on it and secure the Manipulator to the delivery equipment or hold the bottom of Arm #1 and or bottom of the base areas (indicated in gray in the figure) by hand. When holding the bottom of the base by hand, be very careful not to get your hands or fingers caught.                             <p style="margin-left: 20px;">T3-401S: approx.16 kg: 35 lb. T6-602S: approx.22 kg: 49 lb.</p> </li> </ul> <div style="text-align: right; margin-right: 50px;">  <p>(Illustration: T3-401S)</p> </div> <ul style="list-style-type: none"> <li>Make sure not to hold the power unit when carrying the manipulator.</li> <li>Stabilize the Manipulator with your hands when hoisting it.</li> <li>When transporting the Manipulator for a long distance, secure it to the delivery equipment directly so that the Manipulator never falls. If necessary, pack the Manipulator in the same style as it was delivered.</li> </ul>
--	---

### 3.5 Installation Procedure

 CAUTION	<ul style="list-style-type: none"> <li>■ The Manipulator must be installed to avoid interference with buildings, structures, utilities, other machines and equipment that may create a trapping hazard or pinch points.</li> <li>■ Oscillation (resonance) may occur during operation depending on rigidity of the installation table. If the oscillation occurs, improve rigidity of the table or change the speed or acceleration and deceleration settings.</li> <li>■ Install the Table Top Mounting Manipulator with two or more people. The Manipulator weights are as follows. Be careful not to get hands, fingers, or feet caught and/or have equipment damaged by a fall of the Manipulator.                       T3-401S: approx.16 kg: 35 lb.                      T6-602S: approx.22 kg: 49 lb.</li> </ul>
--	--

NOTE  Secure the base to the base table with four bolts.  
 Use bolts with specifications conforming to ISO898-1 Property Class: 10.9 or 12.9.

Tightening torque:  $32.0 \pm 1.6 \text{ N}\cdot\text{m}$

NOTE  Make sure to remove wire tie for mechanical stop protector.

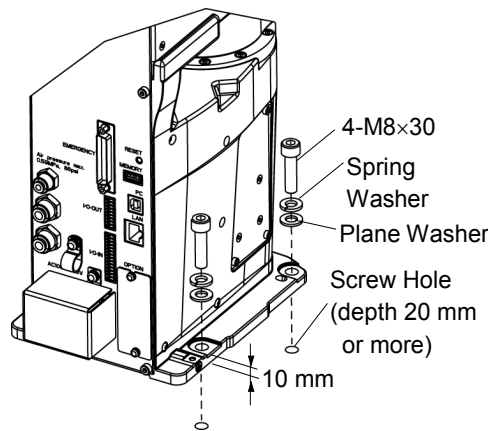

(Illustration: T3-401S)

### 3.6 Power Supply

 WARNING	<ul style="list-style-type: none"> <li>■ There is no power switch on the Manipulator. Right after inserting power plug to power, the Robot System turns ON.</li> </ul> <p>Be careful about electric shock when inserting power plug.</p>
--	--

#### 3.6.1 Specifications

Ensure that the available power meets following specifications.

Item	Specification
Voltage	100 to 240 VAC (Input voltage should be with in $\pm 10\%$ of the rated voltage.)
Phase	Single phase
Frequency	50/60 Hz
Momentary Power Interrupt	Less than 10 msec.
Power Consumption	T3: 660 VA T6: 1,200VA
Peak Current (When AC power is turned ON)	T3: approximately 30A (Less than 2 ms.) T6: approximately 60A (Less than 2 ms.)
Voltage	Max. 10 mA
Ground Resistance	100 $\Omega$ or less

#### 3.6.2 AC Power Cable

 WARNING	<ul style="list-style-type: none"> <li>■ Make sure that the operations are done by a qualified personal.</li> <li>■ Be sure to connect the earth wire (green/yellow) of the AC power cable to the earth terminal of the factory power supply. Also, we recommend to ground directly via a hole on the base to ground the manipulator completely. The equipment must be grounded properly at all times to avoid the risk of electric shock.</li> <li>■ Always use a plug or a disconnecting device for power connecting cable. Never connect the Controller directly to the factory power supply.</li> <li>■ Select a plug or a disconnecting device which conforms to safety standards of each country.</li> </ul>
--	--

When connecting the connector of AC cable to the Manipulator, make sure to insert completely.

#### Connection Specification of Cable Wire

Item	Specification
AC power wire (2 cables)	Black, White
Ground wire	Green/Yellow
Cable length	5 m
Terminal	M4 round solderless terminal

Use cable clamp on rear side of the Manipulator to fix AC power cable.

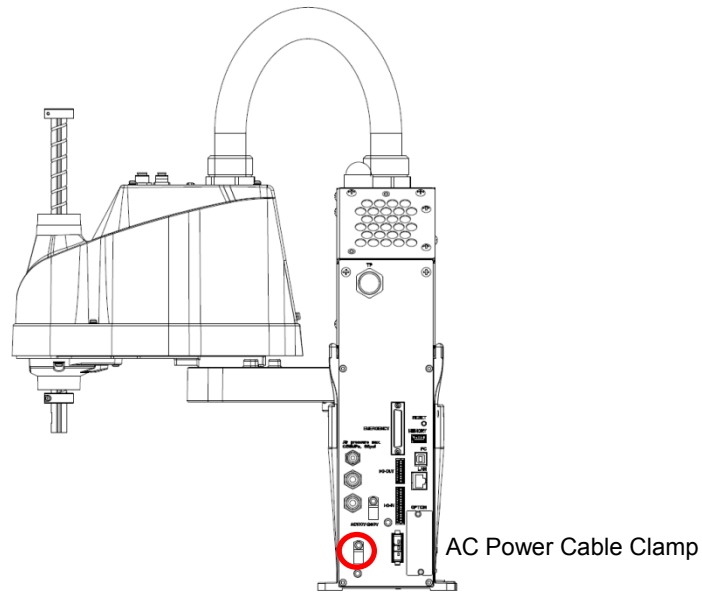

(Illustration: T3-401S)

### 3.6.3 Breaker

Install an earth leakage circuit breaker or a circuit breaker in the AC power cable line. For the rated electric current of the circuit breaker, refer to the following set values.

Manipulator	Power	Rated electric current
T3	AC100V	10A
	AC200V	5A
T6	AC100V	20A
	AC200V	10A

If you install a circuit breaker, please select one that can handle the “peak current” described in the following section.

#### *Setup & Operation 3.6.1 Specifications*

The power receptacle shall be installed near the equipment and shall be easily accessible.

### 3.6.4 Power Unit



WARNING

- Before performing maintenance of power unit, turn OFF the Robot system and related equipment, and then disconnect the power plug from the power source.  
Performing any replacement procedure with the power ON is extremely hazardous and may result in electric shock and/or malfunction of the robot system.
- Do not apply a load by applying weight to power unit. Doing so may result in deformation or damage of parts.
- NEVER connect deformed or damaged power unit to the Robot system or related equipment. It may result in the fire or electric shock.

T3

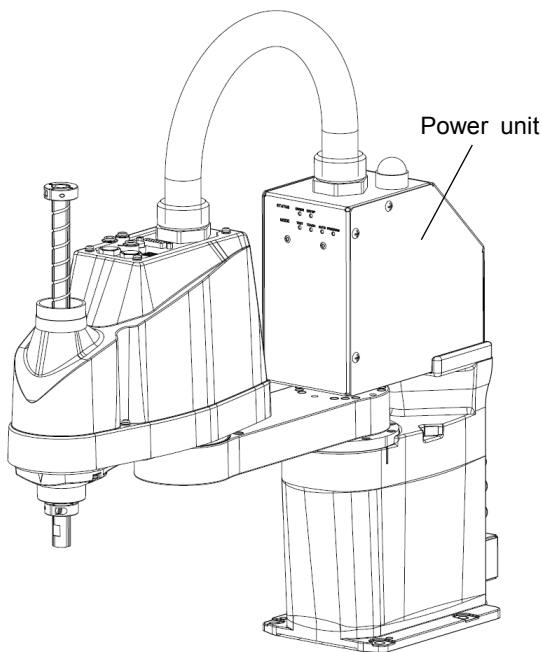

T6

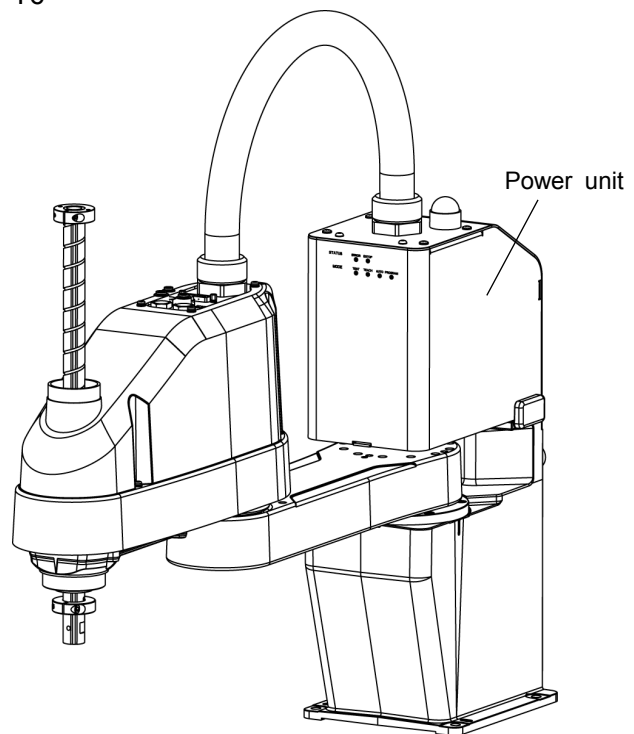



### 3.6.5 Grounding



- Ground resistance must be 100  $\Omega$  or less. Improper ground resistance may result in fire and/or electric shock.
- Do not use the ground line for the Manipulator in common with other ground lines or grounding electrodes for other electric power, motor power, welding devices, etc. Using the ground line for the Manipulator in common with other ground lines or grounding electrodes may result in electric shock and/or malfunction of the robot system.
- When using metal ducts, metallic conduits, or distributing racks for cable, ground in accordance with national and local electric equipment technical standards. Grounding that does not meet the standards may result in electric shock and/or malfunction of the robot system.

Follow local regulations for grounding. It is recommended that the core size of the grounding wire be 5.5 mm<sup>2</sup> or more.

Directly connect the ground line to the Manipulator using bolt hole in the figure below.

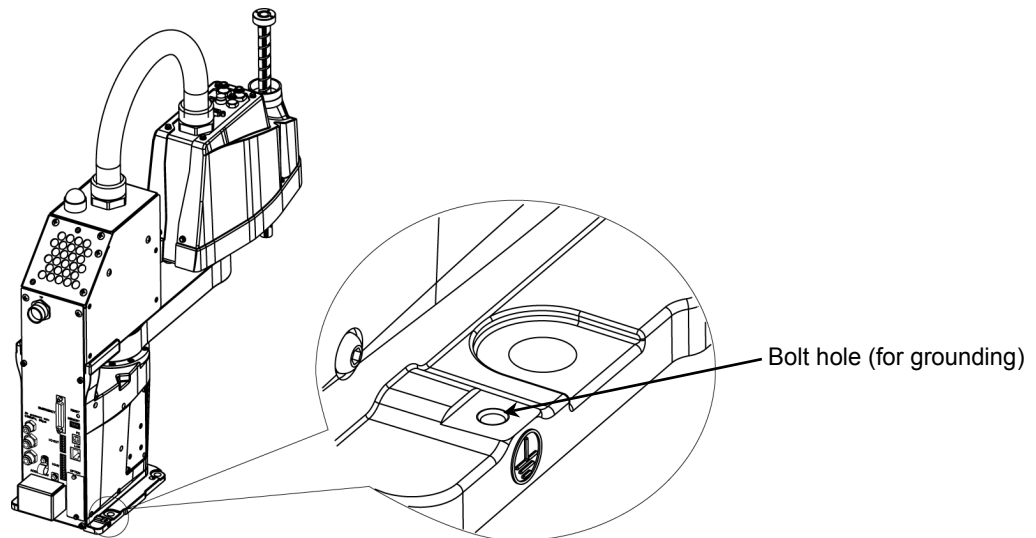

(Illustration: T3-401S)

### 3.7 Connecting the Cables

 <p>WARNING</p>	<ul style="list-style-type: none"><li>■ To shut off power to the robot system, disconnect the power plug from the power source. Be sure to connect the AC power cable to a power receptacle. DO NOT connect it directly to a factory power source.</li><li>■ Before performing any replacement procedure, turn OFF the Controller and related equipment, and then disconnect the power plug from the power source. Performing any replacement procedure with the power ON is extremely hazardous and may result in electric shock and/or malfunction of the robot system.</li><li>■ Be sure to connect the cables properly. Do not allow unnecessary strain on the cables. (Do not put heavy objects on the cables. Do not bend or pull the cables forcibly.) The unnecessary strain on the cables may result in damage to the cables, disconnection, and/or contact failure. Damaged cables, disconnection, or contact failure is extremely hazardous and may result in electric shock and/or improper function of the robot system.</li><li>■ Grounding the manipulator is done by connecting with Power cable. Ensure that the Power cable and ground wire are correctly connected. If the ground wire is improperly connected to ground, it may result in the fire or electric shock.</li></ul>
--	---

 <p>CAUTION</p>	<ul style="list-style-type: none"><li>■ Make sure that the serial numbers on each equipment match. Improper connection between the Manipulator and Controller may not only cause improper function of the robot system but also serious safety problems.</li><li>■ Before connecting the connector, make sure that the pins are not bent. Connecting with the pins bent may damage the connector and result in malfunction of the robot system.</li></ul>
--	---

## 3.7.1 Connection Example

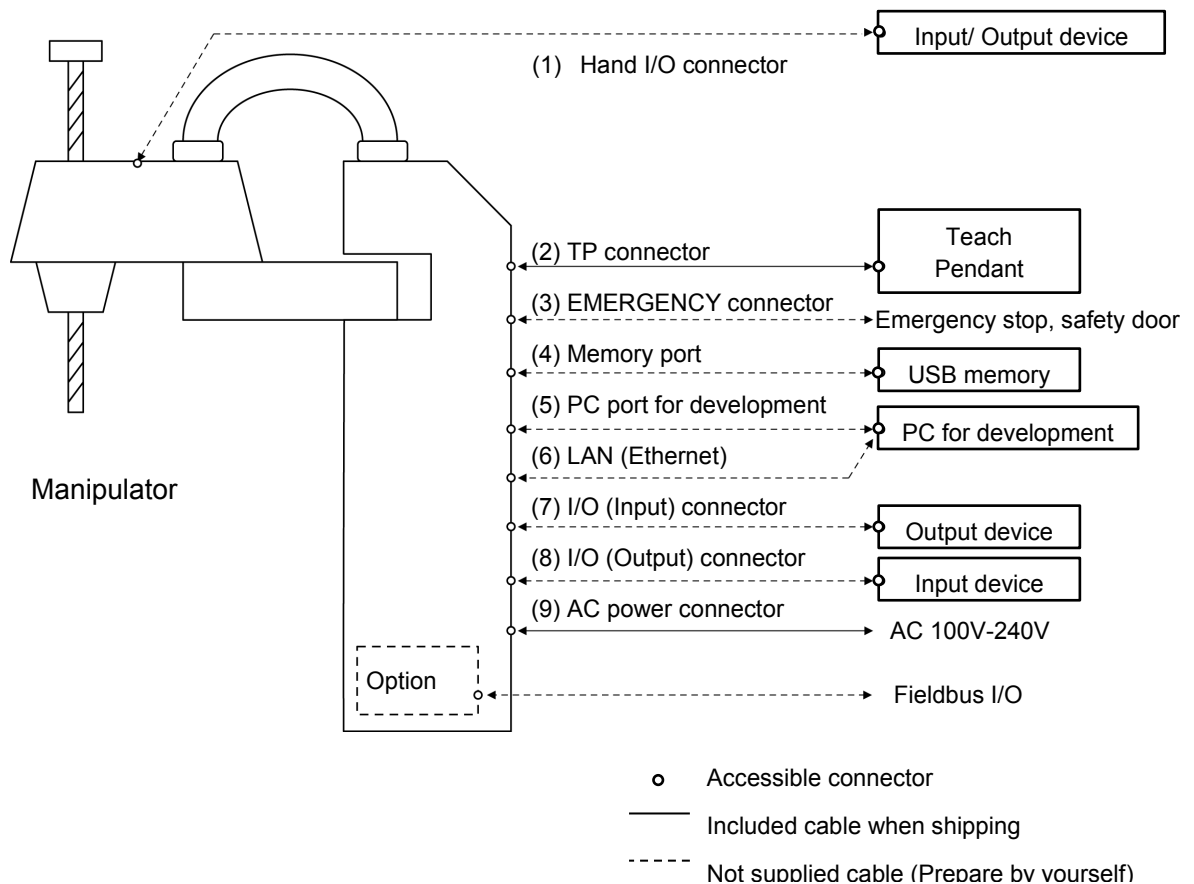

- (1) Hand I/O connector  
 Connect input/output devices of the users.  
 When there are input/output devices, use this connector.  
 Be careful about allowable current when using hand I/O connector.  
 For details, refer to the *Setup & Operation 13. Hand I/O connector*.
- (2) TP connector  
 Connect the option Teach Pendant.  
 For details, refer to the *Setup & Operation 10. TP Port*.
- (3) EMERGENCY  
 The EMERGENCY connector has inputs to connect the Emergency Stop switch and the Safety Door switch. For safety reasons, connect proper switches for these input devices.  
 For details, refer to the *Setup & Operation 11. EMERGENCY*.
- (4) Memory port  
 Connect to USB memory.  
 For details, refer to the *Setup & Operation 8. Memory port*.
- (5) PC for development  
 Connect the PC for development.  
 For details, refer to the *Setup & Operation 7. Development PC Connection Port*
- (6) LAN (EtherNet Communication)  
 Connect the EtherNet cable.  
 For details, refer to the *Setup & Operation 9. LAN (Ethernet Communication) Port*.

- (7) I/O (Input) connector  
 This input connector is for output device of the user.  
 When there is output device, use this connector.  
 For details, refer to the *Setup & Operation 12. Standard I/O connector*.
- (8) I/O (Output) connector  
 This output connector is for input device of the user.  
 When there is input device, use this connector.  
 For details, refer to the *Setup & Operation 12. Standard I/O connector*.
- (9) AC power connector  
 Connector for AC power supply to the manipulator.

### 3.7.2 Noise Countermeasures

To minimize electrical noise conditions, the following items must be observed in the system's cable wiring:

- The earth wire of the power supply should be grounded. (Ground resistance: 100  $\Omega$  or less) It is important to ground the frame of Manipulator not only for prevention from electric shock, but also for reducing the influence of electric noise around the Manipulator. Therefore, be sure to connect the earth wire (yellow/green) of the Manipulator's power cable to the ground terminal of the factory power supply. For details about the plug and AC power cable, refer to the *Setup & Operation 3.6 Power Supply*.
- Do not tap power from a power line that connects to any equipment which may cause noise.
- Do not run AC power lines and DC power lines in the same wiring duct, and separate them as far as possible. For example, separate the AC motor power line and the Manipulator power line as far as possible from the sensor or valve I/O lines; and do not bundle both sets of wiring with the same cable tie. If more than one duct/cable must cross each other, they should cross perpendicularly. The preferable example is shown in the right figure.

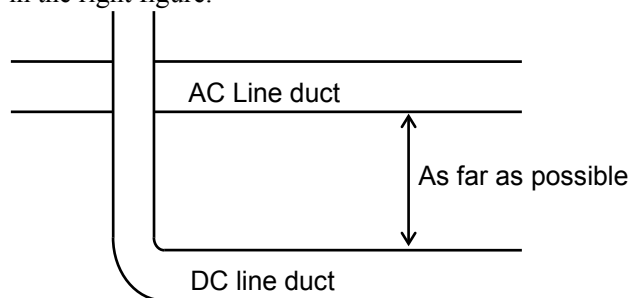

- Wire as short as possible to the I/O connector and EMERGENCY connector. Use a shielded cable and clamp the shield to the attached connector interior. Make sure to keep away from the peripheral noise source as far as possible.
- Make sure that the induction elements used to connect to the Manipulator's I/O (such as relays and solenoid valves) are noise suppression parts. If an induction element without protection against noise is used, make sure to connect a noise suppression part such as a diode located at the induction element in parallel with it. In selecting noise suppression parts, make sure that they can handle the voltage and current incurred by the induction load.
- As they are easily influenced by noise, keep cable such as USB, Ethernet, or fieldbus away from peripheral noise sources.

### 3.8 Pneumatic Tubes

Pneumatic tubes are contained in the cable unit.

Max. Usable Pneumatic Pressure	Pneumatic Tubes	Outer Diameter × Inner Diameter
0.59 MPa (6 kgf/cm <sup>2</sup> : 86 psi)	2	ø 6 mm × ø 4 mm
	1	ø 4 mm × ø 2.5 mm

Fittings for ø6 mm and ø4 mm (outer diameter) pneumatic tubes are supplied on both ends of the pneumatic tubes.

T3

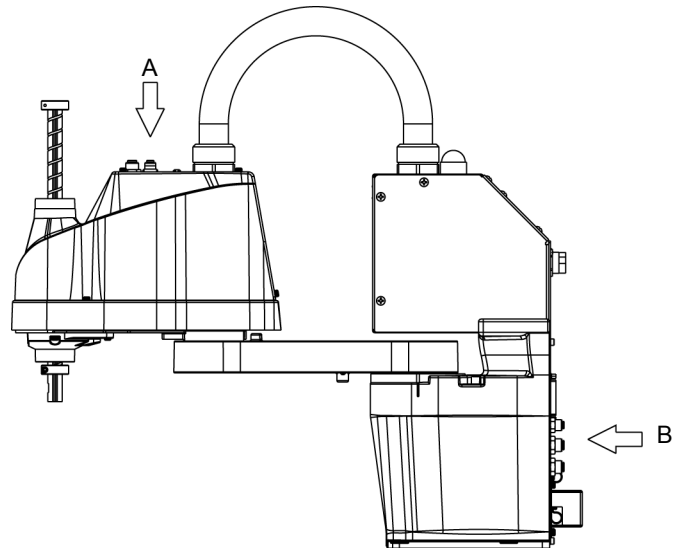

Detail view from A

Detail view from B

Fitting (blue)  
for ø6 mm pneumatic tube

Fitting (blue)  
for ø4 mm pneumatic tube

Fitting (white)  
for ø6 mm pneumatic tube

Fitting (blue)  
for ø4 mm pneumatic tube

Fitting (blue)  
for ø6 mm pneumatic tube

Fitting (white)  
for ø6 mm pneumatic tube

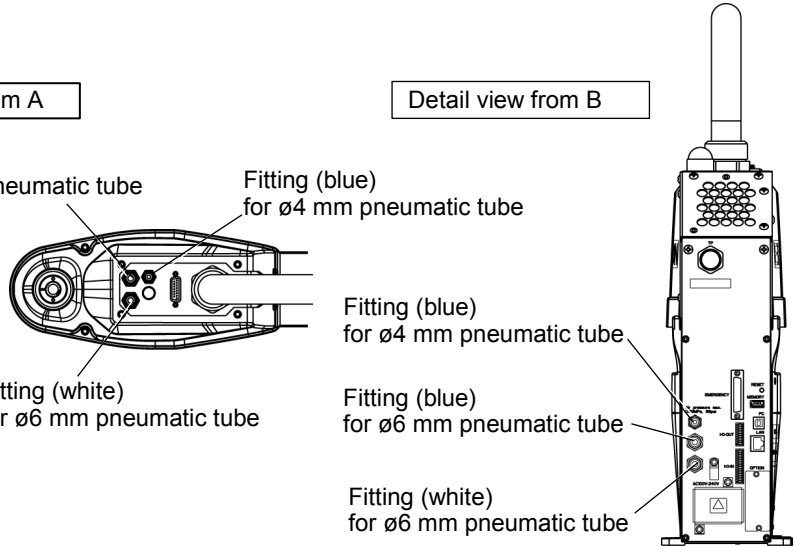

T6

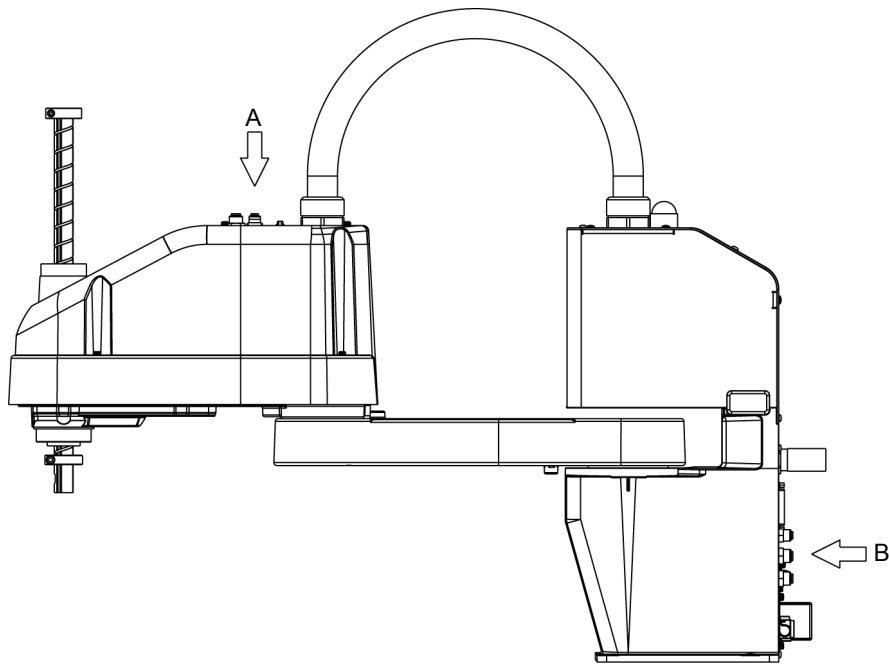

Detail view from A

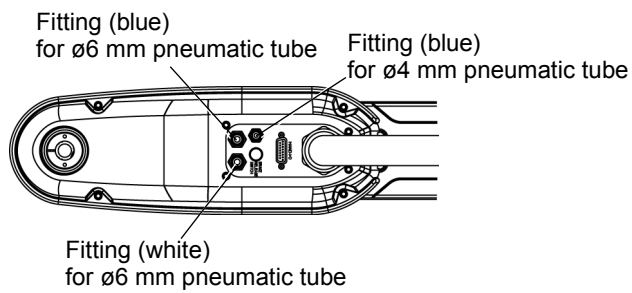

Detail view from B

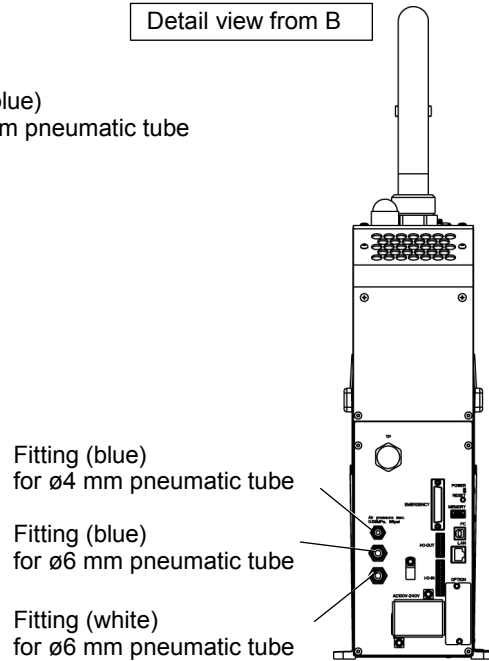

## 3.9 Relocation and Storage

### 3.9.1 Precautions for Relocation and Storage

Observe the following when relocating, storing, and transporting the Manipulators.

THE INSTALLATION SHALL BE PREFORMED BY QUALIFIED INSTALLATION PERSONNEL AND SHOULD CONFORM TO ALL NATIONAL AND LOCAL CODES.



- Only authorized personnel should perform sling work and operate a crane and a forklift. When these operations are performed by unauthorized personnel, it is extremely hazardous and may result in serious bodily injury and/or severe equipment damage to the robot system.



- Before relocating the Manipulator, fold the arm and secure it tightly with a sheet to prevent hands or fingers from being caught in the Manipulator.
- When removing the anchor bolts, support the Manipulator to prevent falling. Removing the anchor bolts without support may result in a fall of the Manipulator, and then get hands, fingers, or feet caught.
- To carry the Manipulator, have two or more people to work on it and secure the Manipulator to the delivery equipment or hold the bottom of Arm #1 and the bottom of the base by hand. When holding the bottom of the base by hand, be very careful not to get hands or fingers caught.
- Stabilize the Manipulator with your hands when hoisting it. Unstable hoisting is extremely hazardous and may result in fall of the Manipulator.

When transporting the Manipulator for a long distance, secure it to the delivery equipment so that the Manipulator cannot fall.

If necessary, pack the Manipulator in the same way as it was delivered.

When the Manipulator is used for a robot system again after long-term storage, perform a test run to verify that it works properly, and then operate it thoroughly.

Transport and store the Manipulator in the range of  $\square 25$  deg.C to +55 deg.C.  
Humidity within 10% to 90% is recommended.

When condensation occurs on the Manipulator during transport or storage, turn ON the power only after the condensation dries.

Do not shock or shake the Manipulator during transport.

### 3.9.2 Relocation

 CAUTION	<ul style="list-style-type: none"> <li>■ Install or relocate the Manipulator with two or more people. The Manipulator weights are as follows. Be careful not to get hands, fingers, or feet caught and/or have equipment damaged by a fall of the Manipulator.</li> </ul> <p style="margin-left: 20px;">T3-401S: approx.16 kg: 35 lb. T6-602S: approx.22 kg: 49 lb.</p>
--	---

- (1) Turn OFF the power on all devices and unplug the cables.

**NOTE**  Remove the mechanical stops if using them to limit the motion range of Joints #1 and #2. For details on the motion range, refer to *Setup & Operation: 5.2 Motion Range Setting by Mechanical Stops*.

- (2) Cover the Arm #2 and Power Supply Unit with a sheet so that the arm will not be damaged.

Example of Arm Retaining Posture

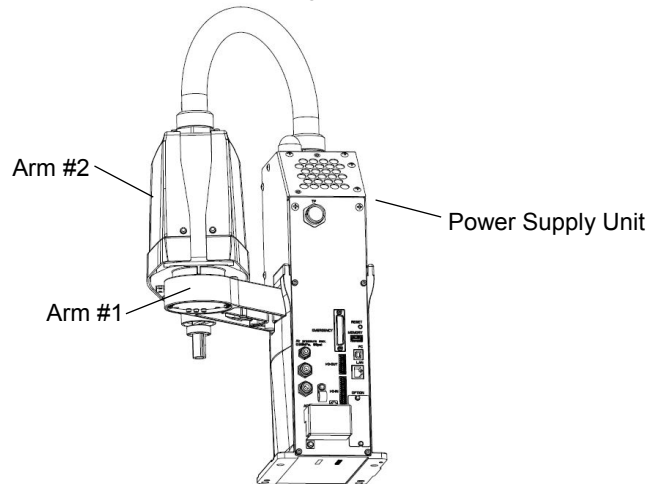

(Illustration: T3-401S)

- (3) Hold the bottom of Arm #1 by hand to unscrew the anchor bolts. Then, remove the Manipulator from the base table.



## 4. Setting of End Effectors

### 4.1 Attaching an End Effector

Users are responsible for making their own end effector(s). Before attaching an end effector, observe these guidelines.



CAUTION

- If you use an end effector equipped with a gripper or chuck, connect wires and/or pneumatic tubes properly so that the gripper does not release the work piece when the power to the robot system is turned OFF. Improper connection of the wires and/or pneumatic tubes may damage the robot system and/or work piece as the work piece is released when the Emergency Stop switch is pressed. I/O outputs are configured at the factory so that they are automatically shut off (0) by power disconnection, the Emergency Stop switch, or the safety features of the robot system.

#### Shaft

- Attach an end effector to the lower end of the shaft.  
For the shaft dimensions, and the overall dimensions of the Manipulator, refer to *Setup & Operation: 2. Specifications*.
- Do not move the upper limit mechanical stop on the lower side of the shaft. Otherwise, when “Jump motion” is performed, the upper limit mechanical stop may hit the Manipulator, and the robot system may not function properly.
- Use a split muff coupling with an M4 bolt or larger to attach the end effector to the shaft.

#### Brake release switch

- Joint #3 cannot be moved up/down by hand because the solenoid brake is applied to the joint while power to the robot system is turned OFF.

This prevents the shaft from hitting peripheral equipment in the case that the shaft is lowered by the weight of the end effector when the power is disconnected during operation, or when the motor is turned OFF even though the power is turned ON.

To move Joint #3 up/down while attaching an end effector, turn ON the Manipulator and press the brake release switch.

This button switch is a momentary-type; the brake is released only while the button switch is being pressed.

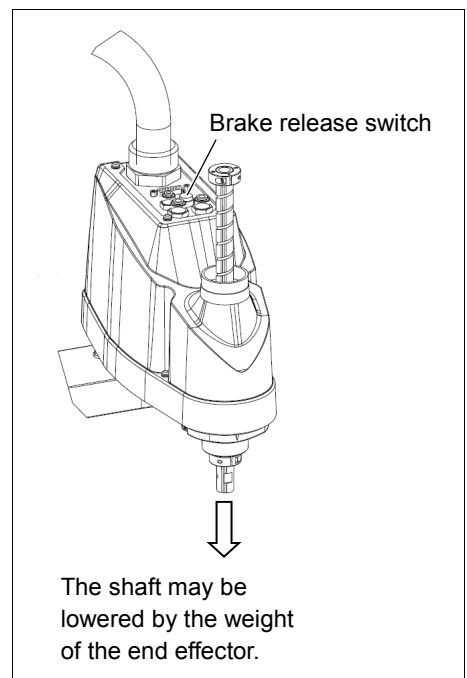

- Be careful of the shaft while the brake release switch is being pressed because the shaft may be lowered by the weight of the end effector.

#### Layouts

- When you operate the manipulator with an end effector, the end effector may interfere with the Manipulator because of the outer diameter of the end effector, the size of the work piece, or the position of the arms. When designing your system layout, pay attention to the interference area of the end effector.

## 4.2 Attaching Cameras and Valves

The bottom of the Arm #2 has threaded holes as shown in the figure below. Use these holes for attaching cameras, valves, and other equipment.

T3

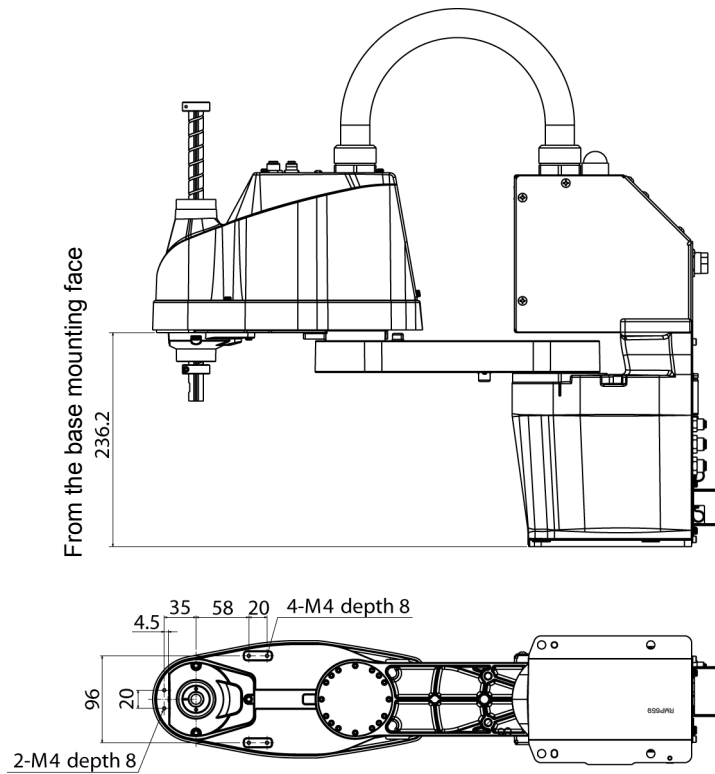

T6

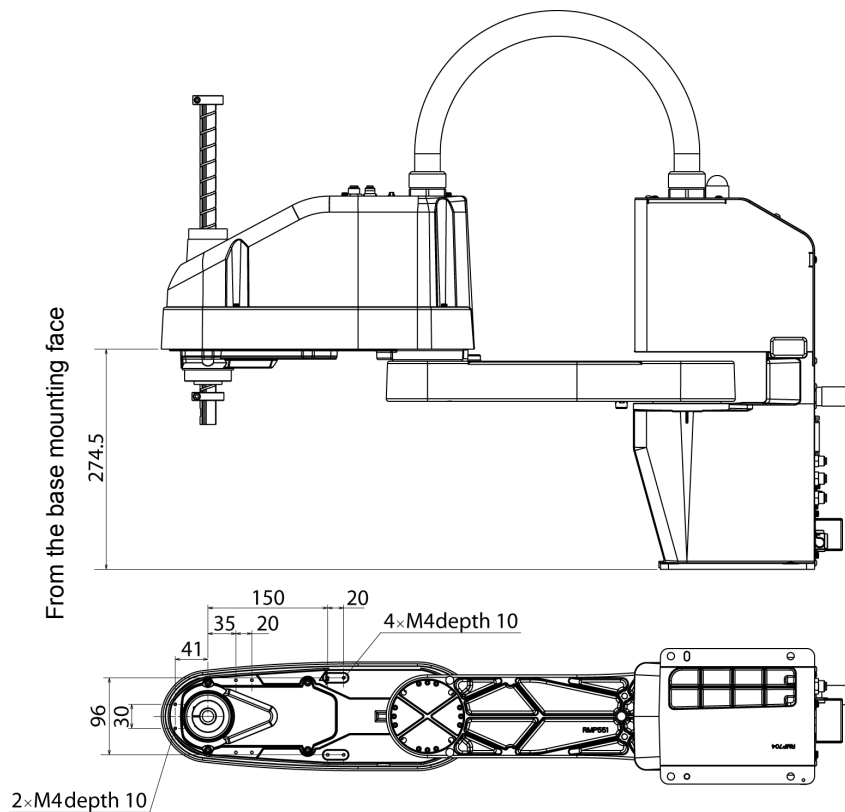

## 4.3 Weight and Inertia Settings

To ensure optimum Manipulator performance, it is important to make sure that the load (weight of the end effector and work piece) and moment of inertia of the load are within the maximum rating for the Manipulator, and that Joint #4 does not become eccentric.

If the load or moment of inertia exceeds the rating or if the load becomes eccentric, follow the steps below, *Setup & Operation: 4.3.1 Weight Setting* and *4.3.2 Inertia Setting* to set parameters.

Setting parameters makes the PTP motion of the Manipulator optimal, reduces vibration to shorten the operating time, and improves the capacity for larger loads. In addition, it reduces persistent vibration produced when the moment of inertia of the end effector and work piece is larger than the default setting.

### 4.3.1 Weight Setting



CAUTION

- The total weight of the end effector and the work piece must not exceed T3: 3kg / T6: 6kg. The T3 series Manipulators are not designed to work with loads exceeding T3: 3kg / T6: 6kg. Always set the Weight parameters according to the load. Setting a value that is smaller than the actual load may cause errors, excessive shock and insufficient function of the Manipulator. Also, the life cycle of parts is shortened and positional gap due to belt tooth bumping occurs.

The acceptable weight capacity (end effector and work piece) in T series:

T3: default rating 1 kg, the maximum 3 kg

T6: default rating 2 kg, the maximum 6 kg

When the load (weight of the end effector and work piece) exceeds the rating, change the setting of Weight parameter.

After the setting is changed, the maximum acceleration/deceleration speed of the robot system at PTP motion corresponding to the “Weight Parameter” is set automatically.

#### Load on the Shaft

The load (weight of the end effector and work piece) on the shaft can be set by Weight parameter.

EPSON  
RC+

Enter a value into the [Load inertia:] text box on the [Inertia] panel ([Tools]-[Robot Manager]). (You may also execute the Inertia command from the [Command Window].)

#### Load on the Arm

When you attach a camera or other devices to the arm, calculate the weight as the equivalent of the shaft. Then, add this to the load and enter the total weight to the Weight parameter

Equivalent Weight Formula

When you attach the equipment near Arm #2:	$W_M = M (L_1)^2 / (L_1 + L_2)^2$
When you attach the equipment to the end of Arm #2:	$W_M = M (L_M)^2 / (L_2)^2$
$W_M$ :	equivalent weight
$M$ :	weight of camera etc.
$L_1$ :	length of Arm #1
$L_2$ :	length of Arm #2
$L_M$ :	distance from rotation center of Joint #2 to center of gravity of camera etc.

<Example>A “1 kg” camera is attached to the end of the T3 series arm (180 mm away from the rotation center of Joint #2) with a load weight of “1 kg”.

$M=1$   
 $L_2=175$   
 $L_M=225$   
 $W_M=1 \times 225^2 / 175^2$   
 $=1.653 \rightarrow 1.7$  (round up)  
 $W+W_M=1+1.7=2.7$

Enter “2.7” for the Weight Parameter.

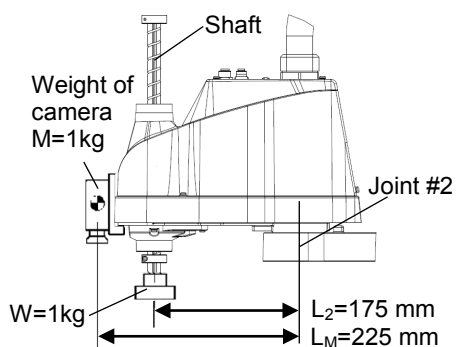

Automatic speed setting by Weight

T3

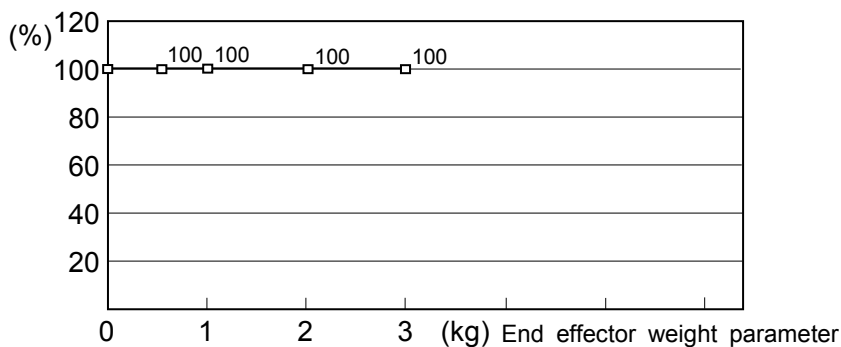

\* The percentage in the graph is based on the speed at rated weight (1 kg) as 100%.

T6

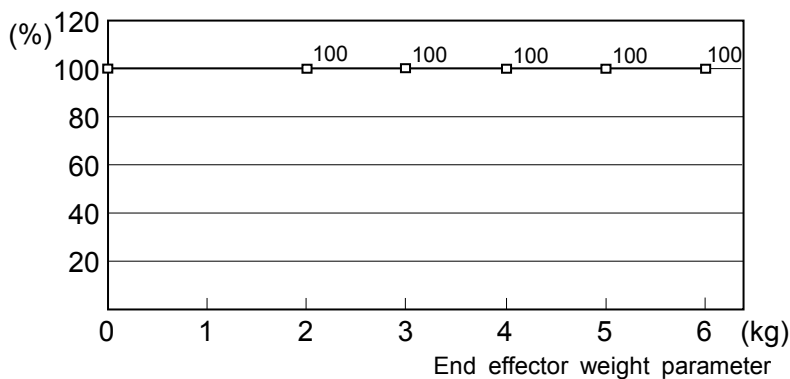

\* The percentage in the graph is based on the speed at rated weight (2 kg) as 100%.

Automatic acceleration/deceleration setting by Weight

T3

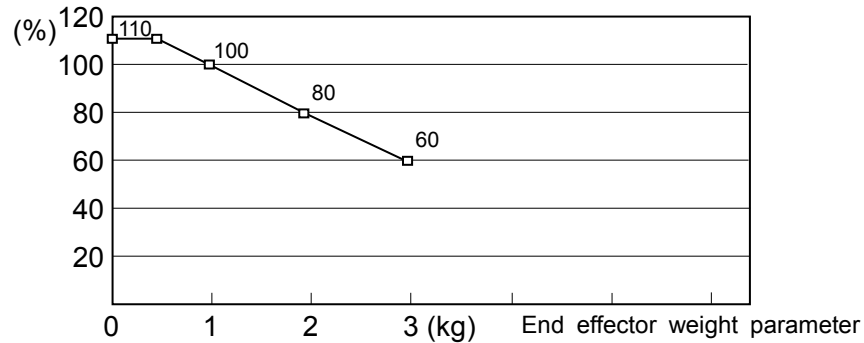

\* The percentage in the graph is based on the speed at rated weight (1 kg) as 100%.

T6

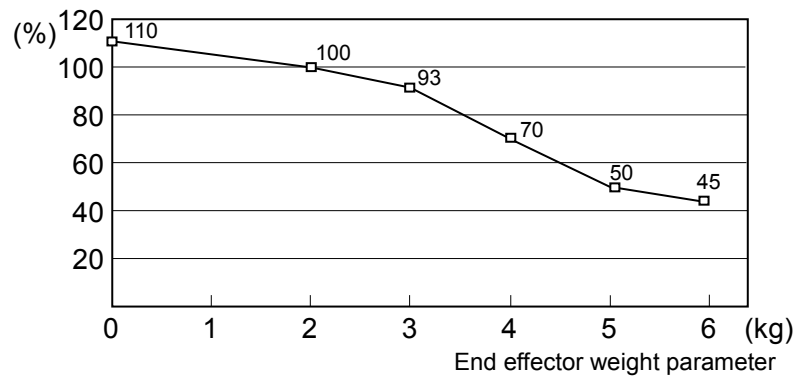

\* The percentage in the graph is based on the speed at rated weight (2 kg) as 100%.

4.3.2 Inertia Setting

Moment of Inertia and the Inertia Setting

The moment of inertia is defined as “the ratio of the torque applied to a rigid body and its resistance to motion”. This value is typically referred to as “the moment of inertia”, “inertia”, or “GD<sup>2</sup>”. When the Manipulator operates with additional objects (such as an end effector) attached to the shaft, the moment of inertia of load must be considered.

 CAUTION	<p>■ The moment of inertia of the load (weight of the end effector and work piece) must be T3: 0.01 kg·m<sup>2</sup> / T6: 0.08 kg·m<sup>2</sup> or less. The T series Manipulators are not designed to work with a moment of inertia exceeding T3: 0.01 kg·m<sup>2</sup> / T6: 0.08 kg·m<sup>2</sup>. Always set the Weight parameters according to the load. Setting a value that is smaller than the actual load may cause errors, excessive shock and insufficient function of the Manipulator. Also, the life cycle of parts is shortened and positional gap due to belt tooth bumping occurs.</p>
--	---

The acceptable moment of inertia of load for a T series Manipulator:

- T3: default rating 0.003 kg·m<sup>2</sup>, the maximum 0.01 kg·m<sup>2</sup>
- T6: default rating 0.01 kg·m<sup>2</sup>, the maximum 0.08 kg·m<sup>2</sup>

When the moment of inertia of the load exceeds the rating, change the setting of the moment of inertia parameter of the Inertia command. After the setting is changed, the maximum acceleration/deceleration speed of Joint #4 at PTP motion corresponding to the “moment of inertia” value is set automatically.

**Moment of inertia of load on the shaft**

The moment of inertia of load (weight of the end effector and work piece) on the shaft can be set by the “moment of inertia” parameter of the Inertia command.

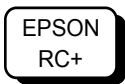

Enter a value into the [Load inertia:] text box on the [Inertia] panel ([Tools]-[Robot Manager]). (You may also execute the Inertia command from the [Command Window].)

**Automatic acceleration/deceleration setting of Joint #4 by Inertia (moment of inertia)**

T3

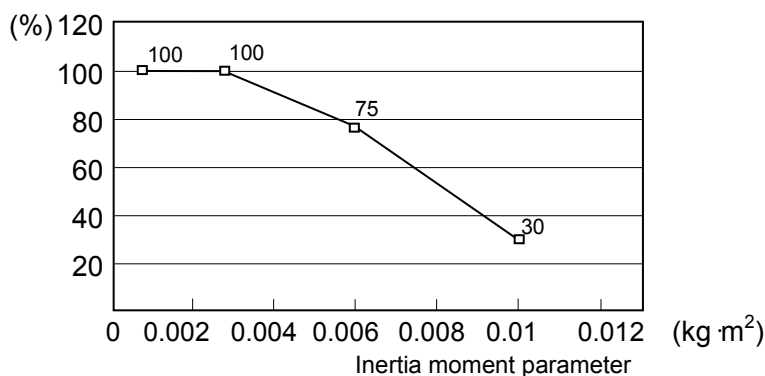

T6

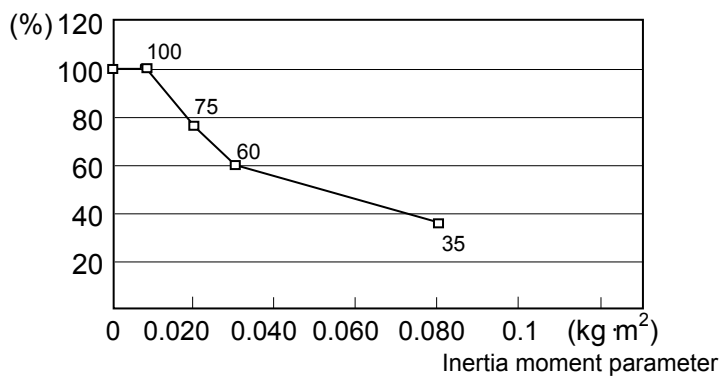

Eccentric Quantity and the Inertia Setting

 CAUTION	<ul style="list-style-type: none"> <li>The eccentric quantity of load (weight of the end effector and work piece) must be T3: 100mm / T6: 150mm or less. The T series Manipulators are not designed to work with eccentric quantity exceeding T3: 100mm / T6: 150mm. Always set the Weight parameters according to the load. Setting a value that is smaller than the actual load may cause errors, excessive shock and insufficient function of the Manipulator. Also, the life cycle of parts is shortened and positional gap due to belt tooth bumping occurs.</li> </ul>
--	--

The acceptable eccentric quantity of load in T series:

T3: default rating 0 mm, at the maximum: 100 mm

T6: default rating 0 mm, at the maximum: 150 mm

When the eccentric quantity of load exceeds the rating, change the setting of eccentric quantity parameter of Inertia command. After the setting is changed, the maximum acceleration/deceleration speed of the Manipulator at PTP motion corresponding to the “eccentric quantity” is set automatically.

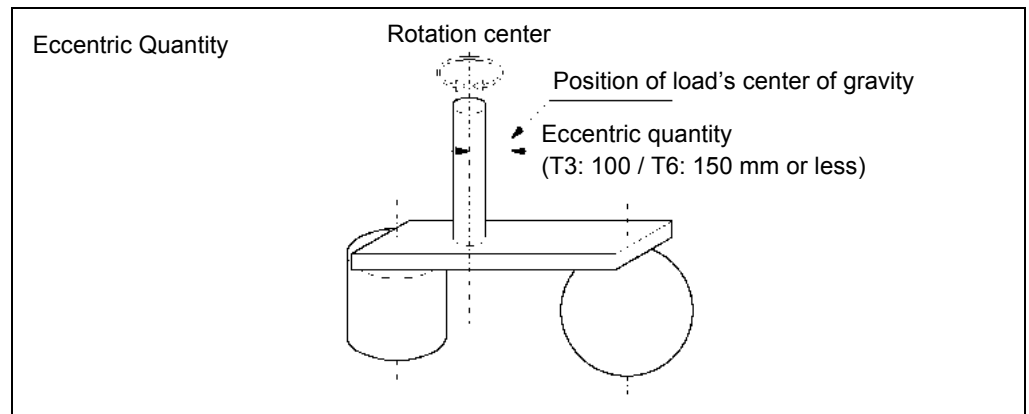

Eccentric quantity of load on the shaft

The eccentric quantity of load (weight of the end effector and work piece) on the shaft can be set by “eccentric quantity” parameter of Inertia command.

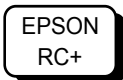

Enter a value into the [Eccentricity:] text box on the [Inertia] panel ([Tools]-[Robot Manager]). (You may also execute the Inertia command from the [Command Window].)

Automatic acceleration/deceleration setting by Inertia (eccentric quantity)

T3

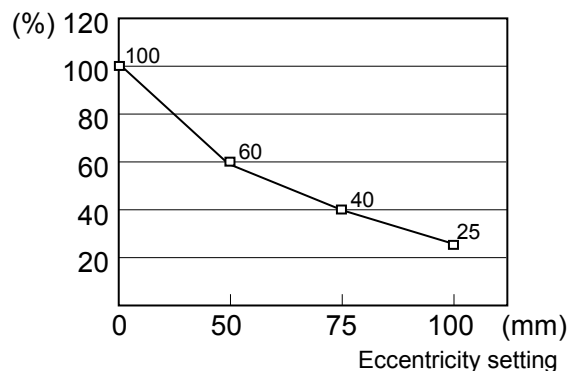

T6

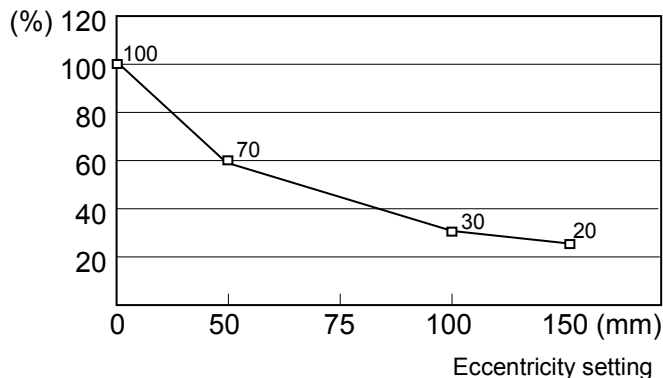

\* The percentage in the graph is based on the acceleration / deceleration at rated eccentricity (0 mm) as 100%.

### Calculating the Moment of Inertia

Refer to the following examples of formulas to calculate the moment of inertia of load (end effector with work piece).

The moment of inertia of the entire load is calculated by the sum of each part (a), (b), and (c).

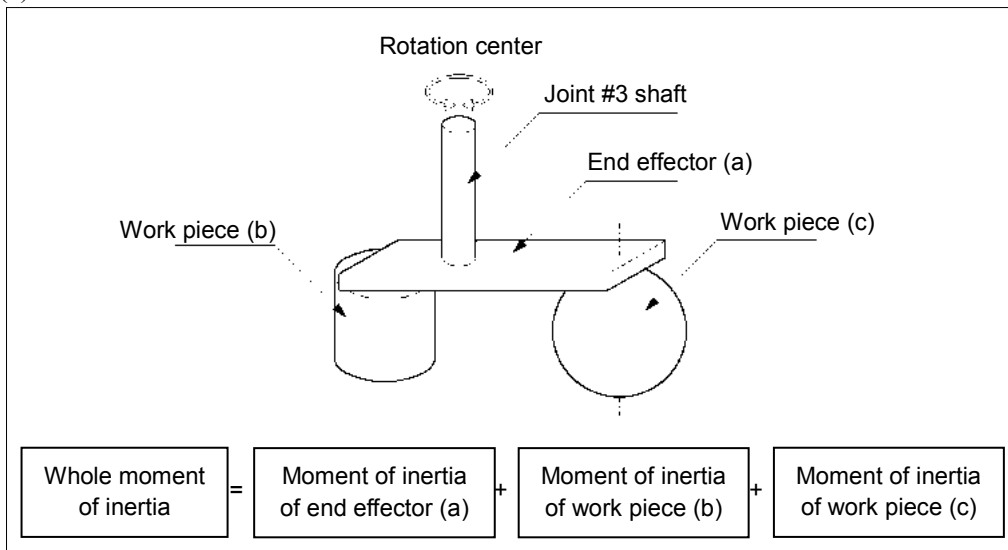

The methods for calculating the moment of inertia for (a), (b), and (c) are shown below. Calculate the total moment of inertia using the basic formulas.



(a) Moment of inertia of a rectangular parallelepiped

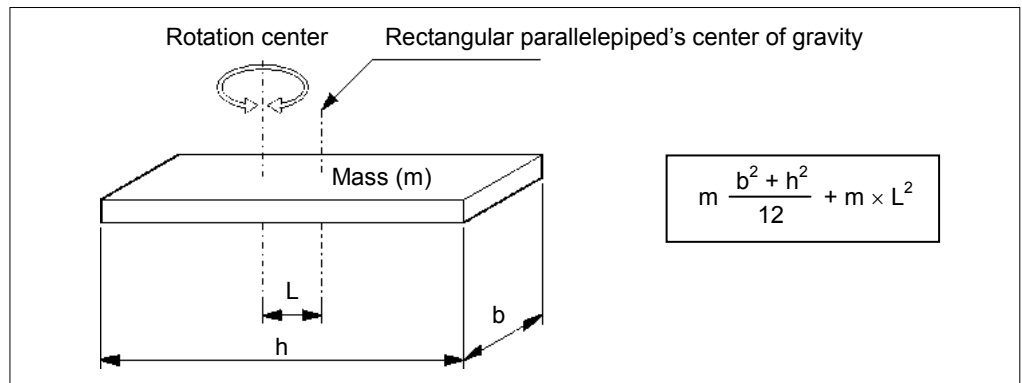

(b) Moment of inertia of a cylinder

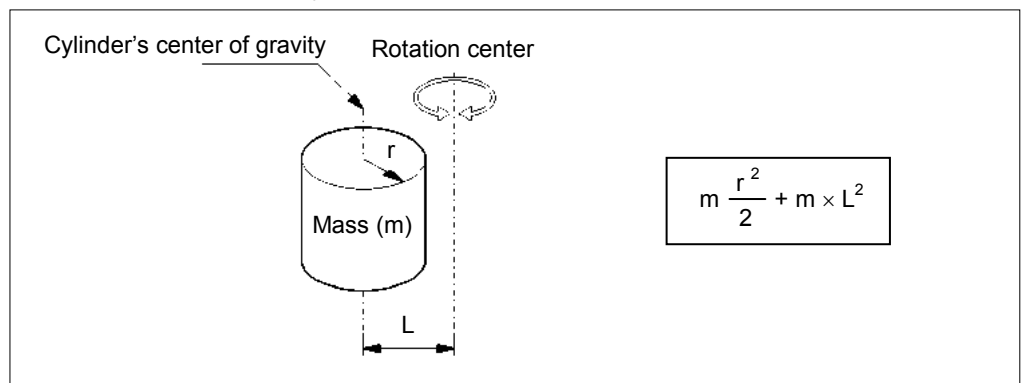

(c) Moment of inertia of a sphere

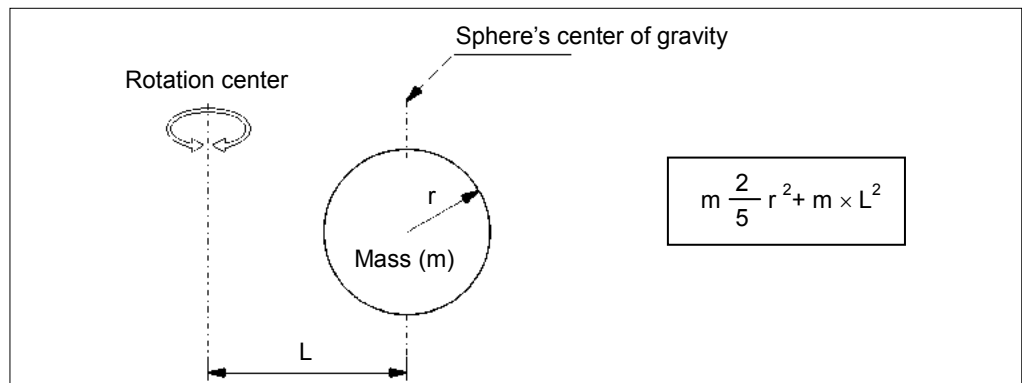

### 4.4 Precautions for Auto Acceleration/Deceleration of Joint #3

When you move the Manipulator in horizontal PTP motion with Joint #3 (Z) at a high position, the motion time will be faster.

When Joint #3 gets below a certain point, then auto acceleration/deceleration is used to reduce acceleration/deceleration. (Refer to the figures below) The higher the position of the shaft is, the faster the motion acceleration/deceleration is. However, it takes more time to move Joint #3 up and down. Adjust the position of Joint #3 for the Manipulator motion after considering the relation between the current position and the destination position.

The upper limit of Joint #3 during horizontal motion using Jump command can be set by the LimZ command.

#### Automatic acceleration/deceleration vs. Joint #3 position

T3

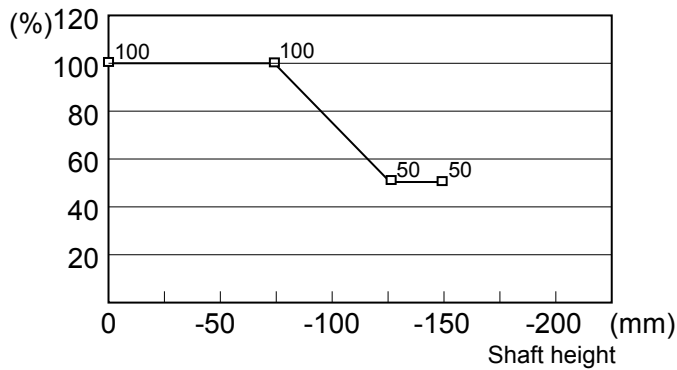

T6

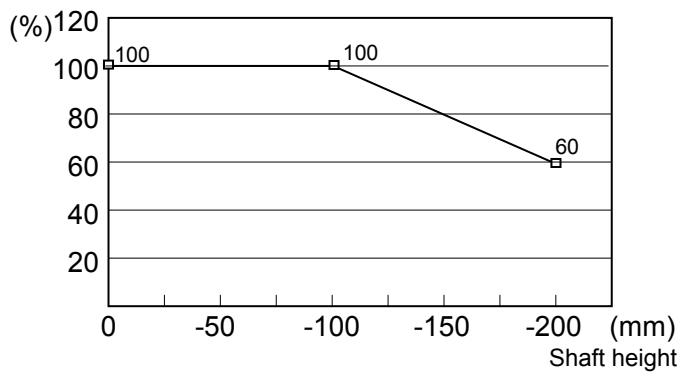

\* Figures on the graph (%) are the proportion to the acceleration/deceleration speed at the shaft upper limit position.



When moving the Manipulator horizontally while the shaft is being lowered, it may cause over-shoot at the time of final positioning.

## 5. Motion Range



- When setting up the motion range for safety, both the pulse range and mechanical stops must always be set at the same time.

The motion range is preset at the factory as explained in *Setup & Operation: 5.4 Standard Motion Range*. That is the maximum motion range of the Manipulator.

There are three methods for setting the motion range described as follows:

1. Setting by pulse range (for all joints)
2. Setting by mechanical stops (for Joints #1 to #3)
3. Setting the Cartesian (rectangular) range in the X, Y coordinate system of the Manipulator (for Joints #1 and #2)

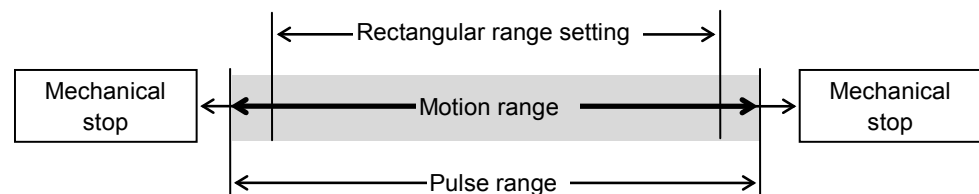

When the motion range is changed due to layout efficiency or safety, follow the descriptions in 5.1 to 5.3 to set the range.

### 5.1 Motion Range Setting by Pulse Range (for All Joints)

Pulses are the basic unit of Manipulator motion. The motion range of the Manipulator is controlled by the pulse range between the pulse lower limit and upper limit of each joint. Pulse values are read from the encoder output of the servo motor.

For the maximum pulse range, refer to the following sections.

The pulse range must be set inside of the mechanical stop range.

*5.1.1 Max. Pulse Range of Joint #1*

*5.1.2 Max. Pulse Range of Joint #2*

*5.1.3 Max. Pulse Range of Joint #3*

*5.1.4 Max. Pulse Range of Joint #4.*



Once the Manipulator receives an operating command, it checks whether the target position specified by the command is within the pulse range before operating. If the target position is out of the set pulse range, an error occurs and the Manipulator does not move.



The pulse range can be set on the [Range] panel shown by selecting [Tools]-[Robot Manager]. (You may also execute the Range command from the [Command Window].)

### 5.1.1 Max. Pulse Range of Joint #1

The 0 (zero) pulse position of Joint #1 is the position where Arm #1 faces toward the positive (+) direction on the X-coordinate axis.

When the 0 pulse is a starting point, the counterclockwise pulse value is defined as the positive (+) and the clockwise pulse value is defined as the negative (-).

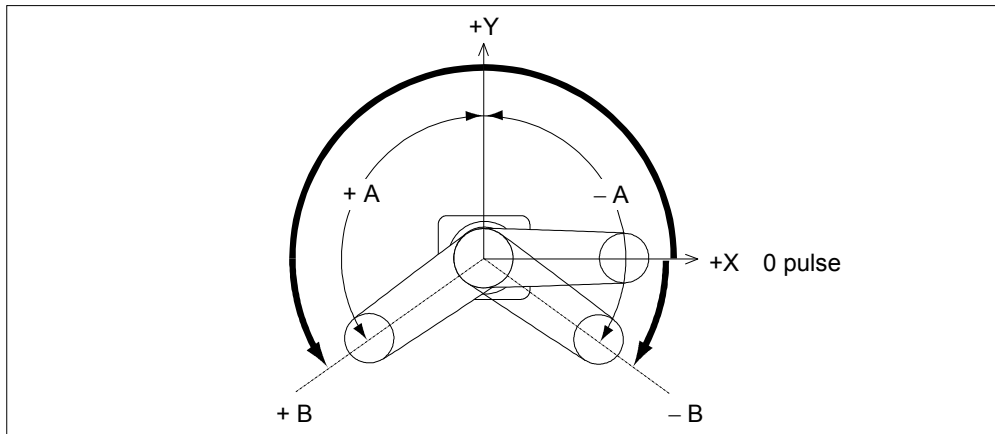

	A: Max. Motion Range	B: Max. Pulse Range
T3	± 132 deg.	- 95574 to 505174 pulse
T6		-152918 to 808278 pulse

### 5.1.2 Max. Pulse Range of Joint #2

The 0 (zero) pulse position of Joint #2 is the position where Arm #2 is in-line with Arm #1.

With the 0 pulse as a starting point, the counterclockwise pulse value is defined as the positive (+) and the clockwise pulse value is defined as the negative (-).

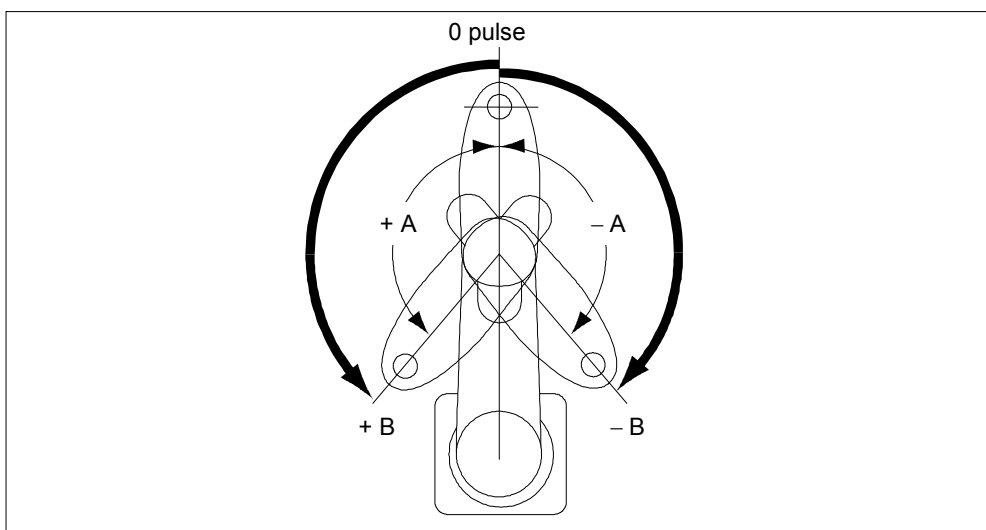

	A: Max. Motion Range	B: Max. Pulse Range
T3	± 141 deg.	± 320854 pulse
T6	± 150 deg.	± 341334 pulse

**5.1.3 Max. Pulse Range of Joint #3**

The 0 (zero) pulse position of Joint #3 is the position where the shaft is at its upper limit. The pulse value is always negative because Joint #3 always moves lower than the 0 pulse position.

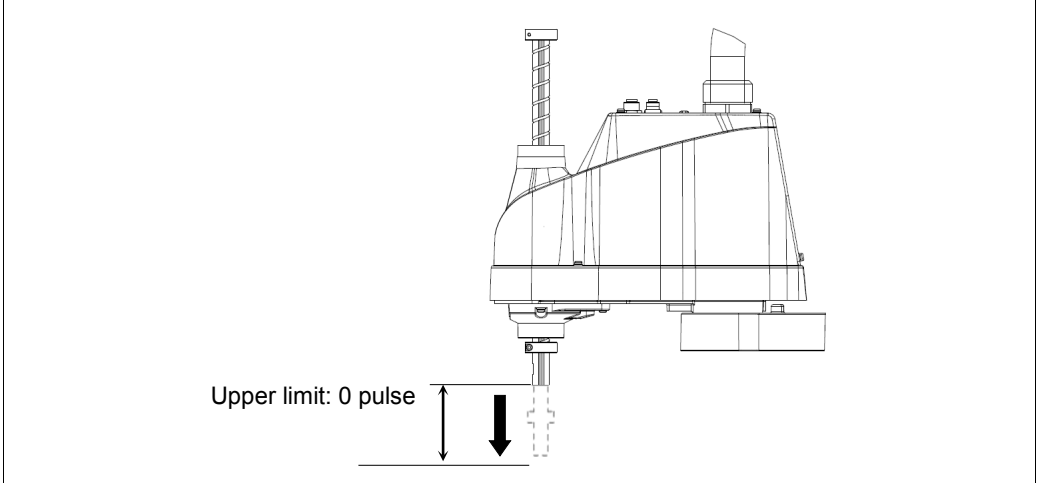

	Joint #3 Stroke	Lower Limit Pulse
T3	150 mm	-187734 pulse
T6	200 mm	-245760 pulse

**5.1.4 Max. Pulse Range of Joint #4**

The 0 (zero) pulse position of Joint #4 is the position where the flat near the end of the shaft faces toward the end of Arm #2. With the 0 pulse as a starting point, the counterclockwise pulse value is defined as the positive (+) and the clockwise pulse value is defined as the negative (-).

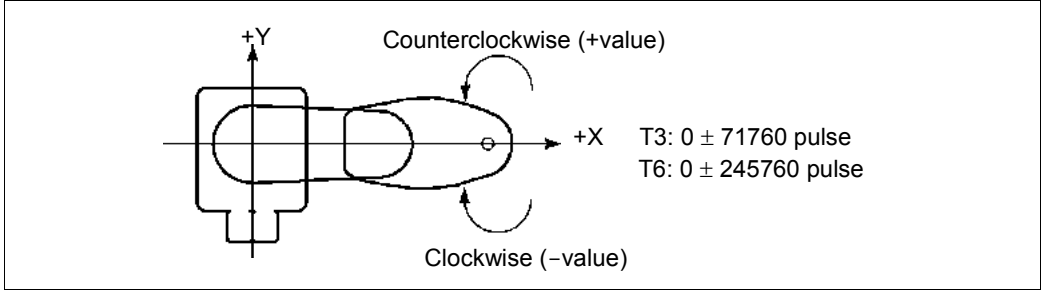

## 5.2 Motion Range Setting by Mechanical Stops

Mechanical stops physically limit the absolute area that the Manipulator can move.

Both Joints #1 and #2 have threaded holes in the positions corresponding to the angle for the mechanical stop settings. Install the bolts in the holes corresponding to the angle that you want to set.

Joints #3 can be set to any length less than the maximum stroke.

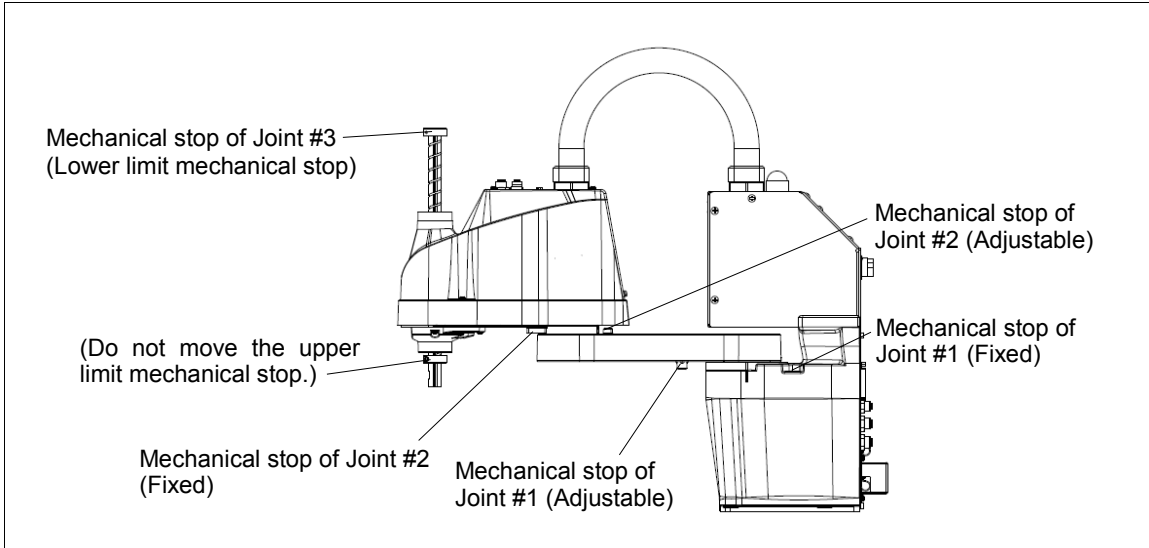

### 5.2.1 Setting the Mechanical Stops of Joints #1 and #2

Both Joints #1 and #2 have threaded holes in the positions corresponding to the angle for the mechanical stop settings. Install the bolts in the holes corresponding to the angle that you want to set.

Install the bolts for the mechanical stop to the following position.  
 Joint #1 Mechanical Stops (Views from the bottom of Arm #1)

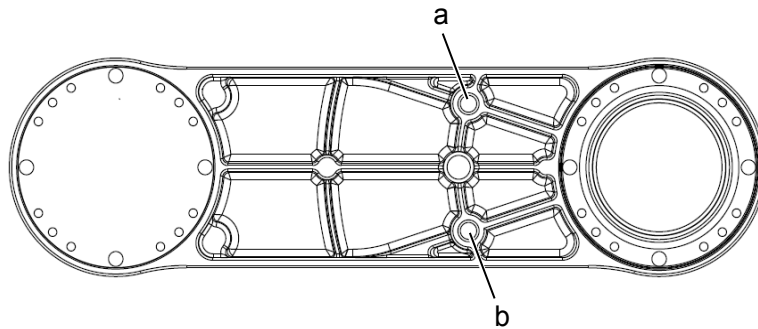

		a	b
T3	Setting Angle	110°	-110°
	Pulse Value	455112 pulse	-45512 pulse
T6	Setting Angle	115°	-115°
	Pulse Value	466489 pulse	-56889 pulse

Joint #2 Mechanical Stops (Views from the top of Arm #1)

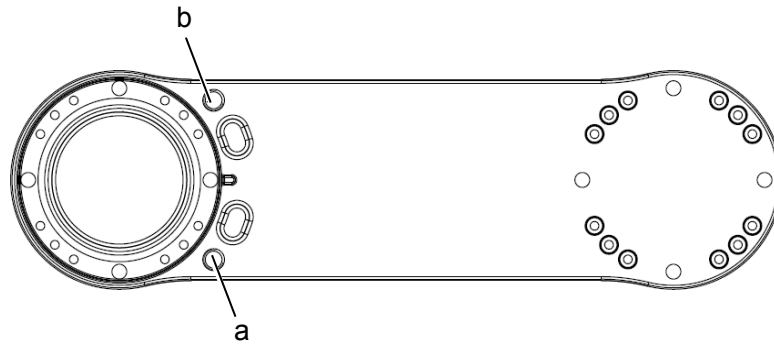

		a	b
T3	Setting Angle	120°	-120°
	Pulse Value	273066pulse	-273066pulse
T6	Setting Angle	125°	-125°
	Pulse Value	284444pulse	-284444pulse

- (1) Turn OFF the Manipulator.
- (2) Install a hexagon socket head cap bolt into the hole corresponding to the setting angle, and tighten it.

T3 Joint #2 only

Remove the user plate on the arm cover.

For details, refer to *Maintenance: 7. Cover*.

Joint	Hexagon socket head cap bolt (fully threaded)	The number of bolts	Recommended tightening torque
1	M8×10 All screws	One for each One side	12.3 N·m (125 kgf·cm)

- (3) Turn ON the Manipulator.
- (4) Set the pulse range corresponding to the new positions of the mechanical stops.

NOTE



Be sure to set the pulse range inside the positions of the mechanical stop range.

Example: Using T3-401S

The angle of Joint #1 is set from -110 degrees to +110 degrees.

The angle of Joint #2 is set from -120 degrees to +120 degrees.



Execute the following commands from the [Command Window]

```
>JRANGE 1, -45512, 455112      ' Sets the pulse range of Joint #1
>JRANGE 2, -273066, 273066    ' Sets the pulse range of Joint #2
>RANGE                          ' Checks the setting using Range
-45512, 455112, -273066, 273066, -187734
,0, -71760, 71760
```

- (5) Move the arm by hand until it touches the mechanical stops, and make sure that the arm does not hit any peripheral equipment during operation.

- (6) Operate the joint changed at low speeds until it reaches the positions of the minimum and maximum pulse range. Make sure that the arm does not hit the mechanical stops. (Check the position of the mechanical stop and the motion range you set.)

Example: Using T3-401S

The angle of Joint #1 is set from -110 degrees to +110 degrees.

The angle of Joint #2 is set from -120 degrees to +120



Execute the following commands from the [Command Window].

>MOTOR ON	' Turns ON the motor
>POWER LOW	' Enters low-power mode
>SPEED 5	' Sets at low speeds
>PULSE -45512, 0, 0, 0	' Moves to the min. pulse position of Joint #1
>PULSE 455112, 0, 0, 0	' Moves to the max. pulse position of Joint #1
>PULSE 204800, -273066, 0, 0	' Moves to the min. pulse position of Joint #2
>PULSE 204800, 273066, 0, 0	' Moves to the max. pulse position of Joint #2

The Pulse command (Go Pulse command) moves all joints to the specified positions at the same time. Specify safe positions after considering motion of not only the joints whose pulse range have been changed, but also other joints.

In this example, Joint #1 is moved to the center of its motion range (pulse value: 204800) when checking Joint #2.

If the arm is hitting the mechanical stops or if an error occurs after the arm hits the mechanical stops, either reset the pulse range to a narrower setting or extend the positions of the mechanical stops within the limit.

### 5.2.2 Setting the Mechanical Stop of Joint #3

- (1) Turn ON the Manipulator and turn OFF the motors using the Motor OFF command.
- (2) Push up the shaft while pressing the brake release switch.

Do not push the shaft up to its upper limit or it will be difficult for the arm top cover to be removed. Push the shaft up to a position where the Joint #3 mechanical stop can be changed.

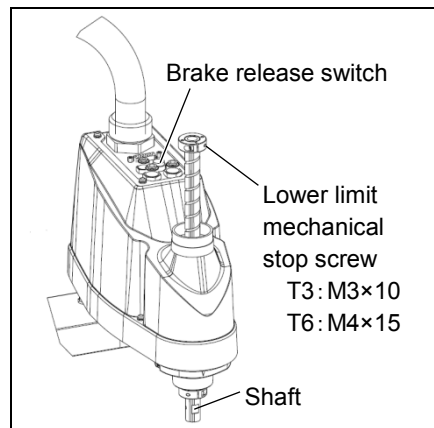

When you press the brake release switch, the shaft may lower due to the weight of the end effector. Be sure to hold the shaft by hand while pressing the button.

- (3) Turn OFF the Manipulator.
- (4) Loosen the lower limit mechanical stop screw (T3: M3x10, T6: M4x15).



**NOTE**  A mechanical stop is mounted on both the top and bottom of Joint #3. However, only the position of the lower limit mechanical stop on the top can be changed. Do not remove the upper limit mechanical stop on the bottom because the calibration point of Joint #3 is specified using the stop.

- (5) The upper end of the shaft defines the maximum stroke. Move the lower limit mechanical stop down by the length you want to limit the stroke.

For example, when the lower limit mechanical stop is set at “150 mm” stroke, the lower limit Z coordinate value is “-150”. To change the value to “-130”, move the lower limit mechanical stop down “20 mm”. Use calipers to measure the distance when adjusting the mechanical stop.

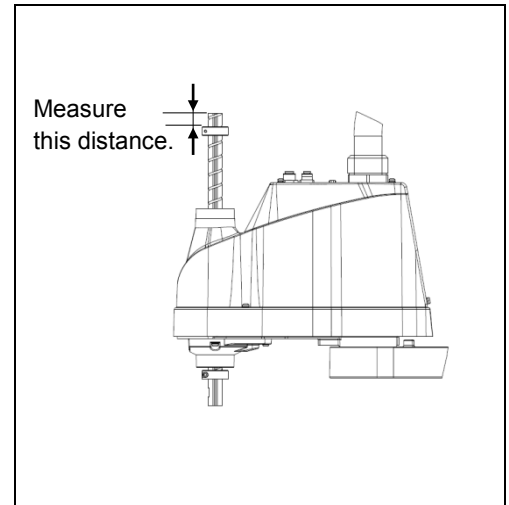

- (6) Firmly tighten the lower limit mechanical stop screw (T3: M3×10, T6: M4×15).

Recommended tightening torque:

T3:  $2.4 \pm 0.1$  N·m

T6:  $5.5 \pm 0.25$  N·m

- (7) Turn ON the Manipulator.
- (8) Move Joint #3 to its lower limit while pressing the brake release switch, and then check the lower limit position. Do not lower the mechanical stop too far. Otherwise, the joint may not reach a target position.
- (9) Calculate the lower limit pulse value of the pulse range using the formula shown below and set the value.

The result of the calculation is always negative because the lower limit Z coordinate value is negative.

$$\begin{aligned} &\text{Lower limit of pulse (pulse)} \\ &= \text{lower limit Z coordinate value (mm)} / \text{Joint \#3 resolution (mm/pulse)**} \end{aligned}$$

\*\* For the Joint #3 resolution,

refer to the section *Setup & Operation 2.4 Specifications*.

**EPSON  
RC+**

Execute the following command from the [Command Window]. Enter the calculated value in X.

>JRANGE 3, X, 0 ' Sets the pulse range of Joint #3

- (10) Using the Pulse command (Go Pulse command), move Joint #3 to the lower limit position of the pulse range at low speed. If the mechanical stop range is less than the pulse range, Joint #3 will hit the mechanical stop and an error will occur. When the error occurs, either change the pulse range to a lower setting or extend the position of the mechanical stop within the limit.

## NOTE



If it is difficult to check whether Joint #3 hits a mechanical stop, turn OFF the Manipulator and lift the arm top cover to check the condition causing the problem from the side.

EPSON  
RC+

Execute the following commands from the [Command Window]. Enter the value calculated in Step (9) in X.

>MOTOR ON ' Turns ON the motor

>SPEED 5 ' Sets low speed

>PULSE 0, 0, X, 0 ' Moves to the lower limit-pulse position of Joint #3.

(In this example, all pulses except those for Joint #3 are “0”. Substitute these “0s” with the other pulse values specifying a position where there is no interference even when lowering Joint #3.)

### 5.3 Setting the Cartesian (Rectangular) Range in the XY Coordinate System of the Manipulator (for Joints #1 and #2)

Use this method to set the upper and lower limits of the X and Y coordinates.

This setting is only enforced by software. Therefore, it does not change the physical range. The maximum physical range is based on the position of the mechanical stops.

EPSON  
RC+

Set the XYLim setting on the [XYZ Limits] panel shown by selecting [Tools]-[Robot Manager].

(You may also execute the XYLim command from the [Command Window].)

### 5.4 Standard Motion Range

The following “motion range” diagrams show the standard (maximum) specification. When each Joint motor is under servo control, the center of Joint #3’s (shaft’s) lowest point moves in the areas shown in the figure.

“Area limited by mechanical stop” is the area where the center of Joint #3’s lowest point can be moved when each joint motor is not under servo control.

“Mechanical stop” sets the limited motion range so that the center of Joint #3 cannot move beyond the area mechanically.

“Maximum space” is the area that contains the farthest reach of the arms. If the maximum radius of the end effector is over 60 mm, add the “Area limited by mechanical stop” and “radius of the end effector”. The total value is specified as the maximum area.

For the motion area figures, refer to *Setup & Operation 3.3 Mounting Dimensions*.

## 6. Operation Mode & LED

### 6.1 Overview

The Robot system has three operation modes.

- |                   |  |
|-------------------|--|
| <b>TEACH mode</b> | This mode enables point data teaching and checking close to the Manipulator using the Teach Pendant.<br>In this mode the Manipulator operates in Low power status.   |
| <b>AUTO mode</b>  | This mode enables automatic operation (program execution) of the Robot system for the manufacturing operation, and also programming, debug, adjustment, and maintenance of the Robot system.<br>This mode cannot operate the Manipulators or run programs with the Safety Door open.   |
| <b>TEST mode</b>  | This mode enables program verification while the Enable Switch is held down and the safeguard is open.<br>This is a low speed program verification function (T1: manual deceleration mode) which is defined in Safety Standards.<br>This mode can operate the specified Function with multi-task / single-task, multi-manipulator / single-manipulator at low speed. |

### 6.2 Switch Operation Mode

Change the operation mode using the mode selector key switch on the Teach Pendant.

- |                   |  |
|-------------------|--|
| <b>TEACH mode</b> | Turn the mode selector key switch to “Teach” for TEACH mode.<br>Switching to TEACH mode pauses the program if it was running.<br>The operating manipulator stops by Quick Pause. |
| <b>AUTO mode</b>  | Turn the mode selector key switch to “Auto” and turn on the latch release input signal for AUTO mode.  |
| <b>TEST mode</b>  | Turn the mode selector key switch to “Teach” for “TEACH” mode.<br>Push <F1> key-[Test Mode] in [Jog & Teach] dialog of TEACH mode. The mode will be changed to TEST              |

## 6.3 Program Mode (AUTO)

### 6.3.1 What is Program Mode (AUTO)?

Program mode is for programming, debug, adjustment, and maintenance of the Robot system.

Follow the procedures below to switch to the Program mode.

### 6.3.2 Setup from EPSON RC+ 7.0

Switch the mode to Program mode from the EPSON RC+ 7.0.

- (1) Select EPSON RC+ 7.0 menu-[Setup]-[System Configuration] to display the [System Configuration] dialog.

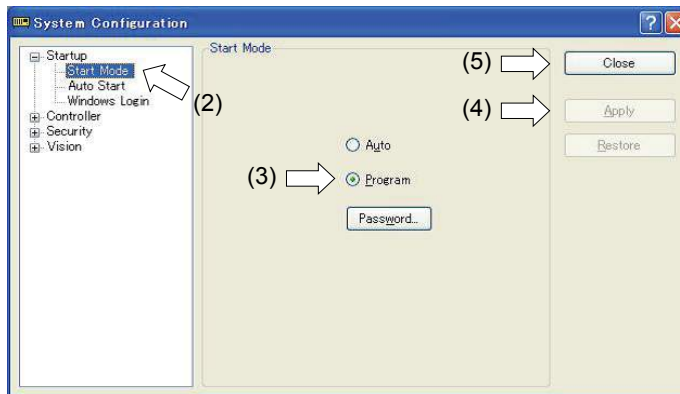

- (2) Select [Startup].
- (3) Select [Start mode]-<Program> button.
- (4) Click the <Apply> button.
- (5) Click the <Close> button.

## 6.4 Auto Mode (AUTO)

### 6.4.1 What is Auto mode (AUTO)?

Auto mode (AUTO) is for automatic operation of the Robot system.

Procedures for switching to the Auto mode (AUTO) are the following.

A : Set the start mode of the EPSON RC+ 7.0 to “Auto” and start the EPSON RC+ 7.0.

(Refer to *Setup & Operation 6.3.2 Setup from EPSON RC+ 7.0.*)

B : Offline the EPSON RC+ 7.0.



Execute and stop the program from the control device specified by the EPSON RC+ 7.0. (Refer to *Setup & Operation 6.4.3 Setup Control Device.*)

### 6.4.2 Setup from EPSON RC+ 7.0

Switch the mode to Auto mode (AUTO) from the EPSON RC+ 7.0.

- (1) Select EPSON RC+ 7.0 menu-[Setup]-[System Configuration] to display the [System Configuration] dialog.

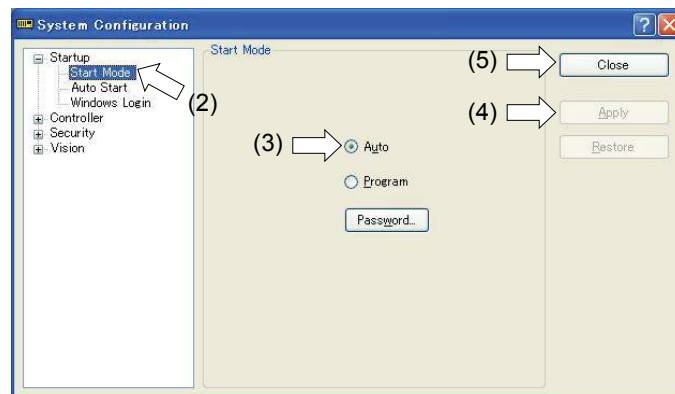

- (2) Select [Startup].
- (3) Select [Start Mode]-<Auto> button.
- (4) Click the <Apply> button.
- (5) Click the <Close> button.

### 6.4.3 Setup from Control Device

Set the control device from EPSON RC+ 7.0.

- (1) Select EPSON RC+ 7.0 menu-[Setup]-[System Configuration] to display the [System Configuration] dialog.

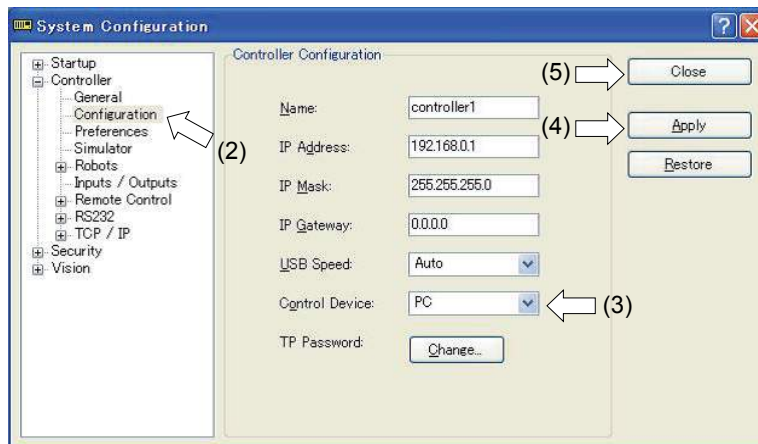

- (2) Select [Controller]-[Configuration].
- (3) Select [Control Device] to select the control device from the following two types.
  - PC
  - Remote (I/O)
- (4) Click the <Apply> button.
- (5) Click the <Close> button.

## 6.5 LED

Six LEDs are located on the front panel of the Manipulator.

LEDs (ERROR, E-STOP, TEACH, TEST, AUTO, PROGRAM) turn ON according to the Controller status (error, Emergency Stop, TEACH mode, Auto mode, Program mode).

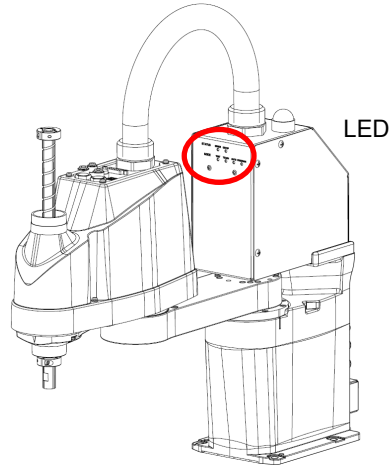

(Illustration: T3-401S)

Controller status	LED display
Start up (Required time is different depending on the connection status of the device.)	<ol style="list-style-type: none"> <li>1. TEST, TEACH, AUTO, and PROGRAM blink (15 seconds)</li> <li>2. All turn OFF (10 seconds)</li> <li>3. All turn ON (10 seconds)</li> <li>4. All turn OFF (10-30 seconds)</li> <li>5. Either of TEACH, AUTO, or PROGRAM turns ON</li> </ol>
Execute Controller status storage function to the USB memory	TEACH AUTO, PROGRAM blink.
Complete Controller status storage to USB memory	TEACH, AUTO, PROGRAM turn ON (for 2 seconds). ERROR turns OFF even if an error occurs.
Failure of Controller status storage to USB memory	ERROR, TEACH, AUTO, PROGRAM turn ON (for 2 seconds).
Error	ERROR turns ON
Warning	ERROR blinks.
Emergency Stop	E-STOP turns ON.
TEACH mode	TEACH blinks.
Auto mode (AUTO mode)	AUTO blinks.
Program mode (AUTO mode)	PROGRAM blinks.
AC power supply drop	TEACH, AUTO turn ON.
Test mode	TEACH blinks.

## 7. Development PC Connection Port

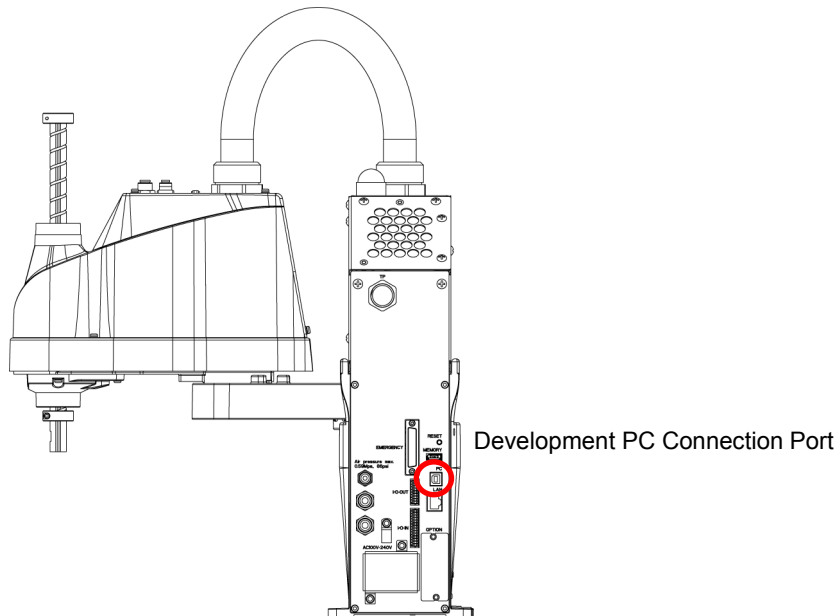

(Illustration: T3-401S)



- NOTE**
- For other details of development PC and Manipulator connection, refer to *EPSON RC+ 7.0 User's Guide 5.12.1 PC to Controller Communications Command*.
  - Be sure to install the EPSON RC+ 7.0 to the development PC first, then connect the development PC and Manipulator with the USB cable.  
If Manipulator and the development PC are connected without installing the EPSON RC+ 7.0 to the development PC, [Add New Hardware Wizard] appears. If this wizard appears, click the <Cancel> button.

### 7.1 What is Development PC Connection Port

The development PC connection port supports the following USB types.

- USB2.0 HighSpeed/FullSpeed (Speed auto selection, or FullSpeed mode)
- USB1.1 FullSpeed

Interface Standard : USB specification Ver.2.0 compliant  
(USB Ver.1.1 upward compatible)

Connect the Manipulator and development PC by a USB cable to develop the robot system or set the Manipulator configuration with the EPSON RC+ 7.0 software installed in the development PC.

Development PC connection port supports hot plug feature. Cables insert and remove from the development PC and the Manipulator are available when the power is ON. However, stop occurs when USB cable is removed from the Manipulator or the development PC during connection.



## 7.2 Precaution

When connecting the development PC and the Manipulator, make sure of the following:

- Connect the development PC and the Manipulator with a 5 m or less USB cable.  
Do not use the USB hub or extension cable.
- Make sure that no other devices except the development PC are used for development PC connection port.
- Use a PC and USB cable that supports USB2.0 HighSpeed mode to operate in USB2.0 HighSpeed mode.
- Do not pull or bend the cable strongly.
- Do not allow unnecessary strain on the cable.
- When the development PC and the Manipulator are connected, do not insert or remove other USB devices from the development PC. Connection with the Manipulator may be lost.

## 7.3 Software Setup and Connection Check

Connection of the development PC and the Manipulator is indicated.

- (1) Make sure that software EPSON RC+ 7.0 is installed to the Manipulator connected to the development PC.  
(Install the software when it is not installed. Refer to *Robot System Safety and Installation* or *EPSON RC+ 7.0 User's Guide*.)
- (2) Connect the development PC and the Manipulator using a USB cable.
- (3) Turn ON the Manipulator.
- (4) Start EPSON RC+ 7.0.
- (5) Select the EPSON RC+ 7.0 menu-[Setup]-[PC to Controller Communications] to display the [PC to Controller Communications] dialog.

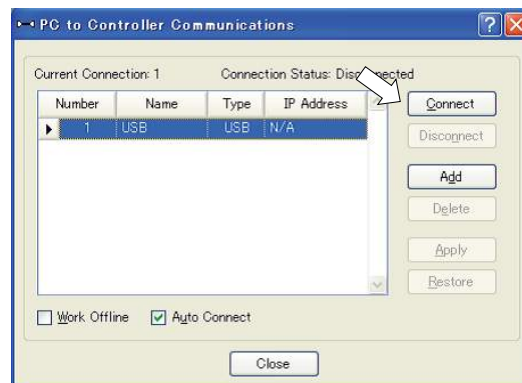

- (6) Select "No.1 USB" and click the <Connect> button.

- (7) After the development PC and the Manipulator connection has completed, “Connected” is displayed at [Connection status]. Make sure that “Connected” is displayed and click the <Close> button to close the [PC to Controller Communications] dialog.

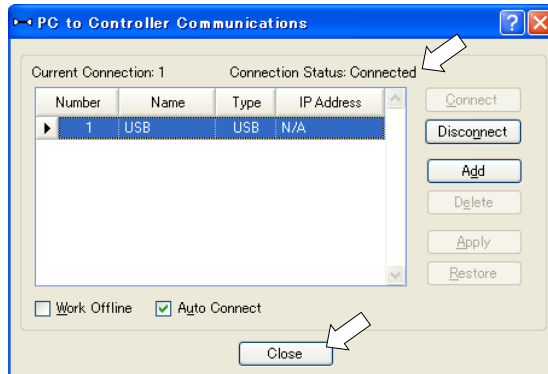

The connection between the development PC and the Manipulator is completed. Now the robot system can be used from EPSON RC+ 7.0.

## 7.4 Disconnection of Development PC and Manipulator

Disconnection of the development PC and the Manipulator communication.

- (1) Select the EPSON RC+ 7.0 menu-[Setup]-[PC to Controller Communications] to display the [PC to Controller Communications] dialog.
- (2) Click the <Disconnect> button.  
Communication between the Manipulator and the development PC is disconnected and the USB cable can be removed.



If the USB cable is removed when the Manipulator and the development PC are connected, the Manipulator will stop. Be sure to click the <Disconnect> button in the [PC to Controller Communications] dialog before USB cable is removed.

## 8. Memory Port

Connect a commercial USB memory to the Manipulator memory port to use the Controller status storage function to the USB memory.

### 8.1 What is Controller Status Storage Function?

This function saves various kinds of Manipulator data to the USB memory. Data saved in USB memory is loaded to EPSON RC+ 7.0 to get the status of the Manipulator and the program simply and accurately.

The saved data can also be used for restoring the Manipulator.

Unable to execute status storage to USB memory when operating the Manipulator.

### 8.2 Before Using Controller Status Storage Function

#### 8.2.1 Precautions



CAUTION

- Controller status storage function is available at any time and in any Manipulator status after starting the Manipulator. However, operations from the console including stop and pause are not available while executing this function. Also, this function influences the Manipulator cycle time and the communication with EPSON RC+ 7.0. Other than only when it is necessary, do not execute this function when operating the Manipulator.

- Make sure that the USB port is used only for USB memory even though the port on the Controller is a universal USB port.
- Insert the USB memory directly into the Manipulator memory port. Connection with cables or hubs between the Manipulator and the USB memory is not assured.
- Make sure that the USB memory is inserted or removed slowly.
- Do not edit the saved files with an editor. Operation of the robot system after data restoration to the Manipulator is not assured.

#### 8.2.2 Adoptable USB Memory

Use USB memory that meets following conditions.

- USB2.0 supported
- Without security function  
USB memory with password input function cannot be used.
- No installation of a driver or software is necessary for Windows XP, Windows 7, Windows 8, or Windows 10, Linux.  
(For supported operating systems for the EPSON RC+ 7.0, refer to *Setup & Operation 2.5 System Example*.)

## 8.3 Controller Status Storage Function

### 8.3.1 Controller Status Storage



CAUTION

- Controller status storage function is available at any time and in any Manipulator status after starting the Manipulator.  
However, operations from the console including stop and pause are not available while executing this function.  
Also, this function influences the Manipulator cycle time and the communication with EPSON RC+ 7.0. Other than only when it is necessary, do not execute this function when operating the Manipulator.

Use this procedure to save the status of the Manipulator to USB memory.

(1) Insert the USB memory into the memory port.

When the data transfer starts, the LED of TEACH, AUTO, and PROGRAM starts blinking. Wait until the LED status changes.

(The data transfer time varies according to the data size such as of the projects.)

(2) When the Manipulator status storage is completed successfully, the LED of TEACH, AUTO, and PROGRAM are turned ON for two seconds. Note that the LED of ERROR turns OFF even in the error status.

If it ends in failure, the LED of ERROR, TEACH, AUTO, and PROGRAM are turned ON for two seconds.

(3) Remove the USB memory from the Manipulator.

#### NOTE



- USB memory with LED is recommended to check the status changes.
- When storage is executed during Motor ON status, it may fail to store the status. Use another USB memory or execute the storage during Motor OFF status.

### 8.3.2 Load Data with EPSON RC+ 7.0

The following shows the procedure to load the data stored in the USB memory by EPSON RC+ 7.0 and display the Controller status.

- (1) Insert the USB memory into the PC with EPSON RC+ 7.0.
- (2) Make sure that the following folder is indicated in the USB memory.  
B\_T\_serial number\_data status was saved  
→ Exmaple: B\_T\_12345\_2013-10-29\_092951
- (3) Copy the folder confirmed in procedure (2) to the “¥EpsonRC70¥Backup” folder.
- (4) Select the EPSON RC+ 7.0 menu-[Tools]-[Controller] to display the [Controller Tools] dialog.

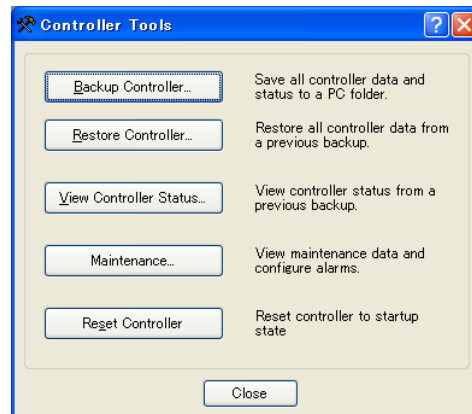

- (5) Click the <View Controller Status...> button.
- (6) [Browse For Folder] dialog appears. Select the folder copied in procedure (3) and click the <OK> button.



- (7) [Controller Status Viewer] dialog appears to confirm the Controller status.  
 For details, refer to *View Controller Status* in *EPSON RC+ 7.0 User's Guide 5.11.8 Controller Command (Tools Menu)*.

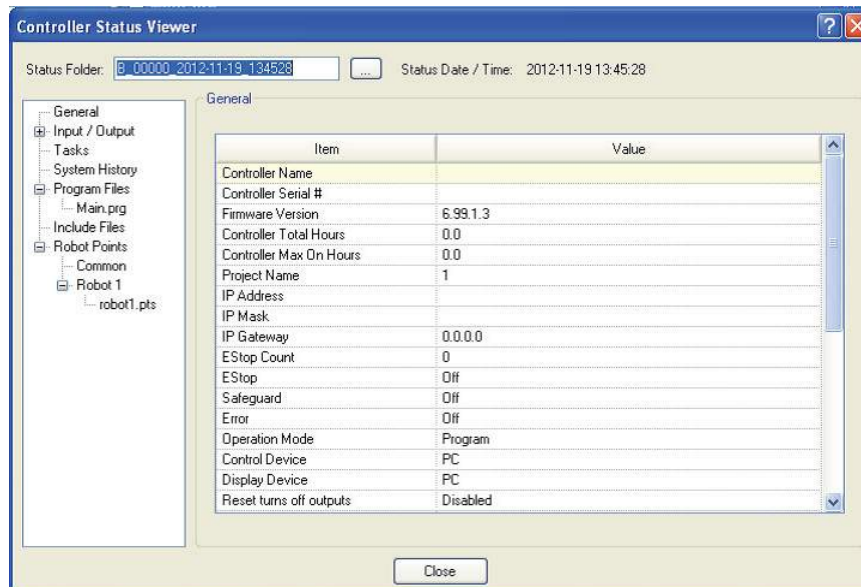

### 8.3.3 Transfer with E-mail

Follow this procedure to transfer the data by e-mail that was saved to the USB memory.

- (1) Insert the USB memory to a PC that supports sending of e-mail.
- (2) Make sure that the USB memory has following folders.  
 B\_T\_serial number\_data status was saved  
 → Exmaple: B\_T\_12345\_2013-10-29\_092951
- (3) Send all the folders by e-mail.

**NOTE**



Delete files that do not relate to the project before transfer.

This function is used to send the data to the system director and EPSON from the end users for problem analysis.

## 8.4 Details of Data

The following data files are created by the Controller status storage function.

File Name	Outline	
Backup.txt	Information file for restore	File with information for Manipulator restore.
CurrentMnp01.PRM	Robot parameter	Saves information such as ToolSet.
CurrentStatus.txt	Save status	Saves program and I/O status.
ErrorHistory.csv	Error history	
InitFileSrc.txt	Initial setting	Saves various settings of the Controller.
MCSys01.MCD	Robot setting	Saves information of connected Manipulator.
SrmeStat.txt	Hardware information	Saves installation information of hardware.
ProjectName.obj	OBJ file	Result of project build. Prg file is not included.
GlobalPreserves.dat	Global Preserve variables	Saves values of Global Preserve variables.
WorkQueues.dat	WorkQue information	Saves information of Queues information of the WorkQue.
MCSRAM.bin MCSYSTEMIO.bin MCTABLE.bin MDATA.bin SERVOSRAM.bin VXDWORK.bin	Inner information of Manipulator	
All files related to project except ProjectName.obj *1	Project	When [Include project files when status exported] check box is checked in EPSON RC+ 7.0 menu-[Setup]-[System Configuration]-[Controller]-[Preference], the project file is stored. Includes program files.

\*1 Storage of “All files related to project except ProjectName.obj” can be specified by a setting.

## 9. LAN (Ethernet Communication) Port

NOTE



- Refer to *EPSON RC+ 7.0 User's Guide 5.12.1 [PC to Controller Communications] Command (Setup Menu)* for other details for the development PC and Manipulator connection.
- For Ethernet (TCP/IP) communication with robot application software, refer to *EPSON RC+ 7.0 Online Help* or *User's Guide 14. TCP/IP Communications*.

### 9.1 What is the LAN (Ethernet Communication) Port

Ethernet communication port supports 100BASE-TX / 10 BASE-T.

This port is used for two different purposes.

#### Connection with development PC

LAN (Ethernet communication) port is used for connection of the Manipulator and the development PC.

Equivalent operation is available to connect between the Manipulator and the development PC with the development PC connection port.

(Refer to *Setup & Operation 7. Development PC Connection Port*)

#### Connection with other Manipulator, Controller, or PC

The LAN (Ethernet communication) port can be used as an Ethernet (TCP/IP) communication port to communicate between multiple controllers from robot application software.

### 9.2 IP Address

Set the proper IP address or subnet mask depending on the Manipulator and development PC configuration to use the LAN port.

Do not input a random value for the IP address of the network configured TCP/IP. This is the only address that specifies the computer using an Internet connection.

The IP address is assigned from the company or organization that has control of IP address.

Use an address from the following Internet private environment such as P2P or line. Make sure that the address is not redundantly assigned inside the closed network.

Private Address List

10.0.0.1	to	10.255.255.254
172.16.0.1	to	172.31.255.254
192.168.0.1	to	192.168.255.254

The following is the configuration of the controller Manipulator at delivery.

- IP Address : 192.168.0.1
- IP Mask : 255.255.255.0
- IP Gateway : 0.0.0.0



### 9.3 Changing Manipulator IP Address

In this section, the procedure to change the Manipulator IP address when connecting Manipulator development PC connection port and the development PC by the USB cable is indicated.

- (1) For connection between the development PC and the Manipulator.  
Refer to *Setup & Operation: 7. Development PC Connection Port*.
- (2) Select the EPSON RC+ 7.0 menu-[Setup]-[Controller] to display the following dialog.

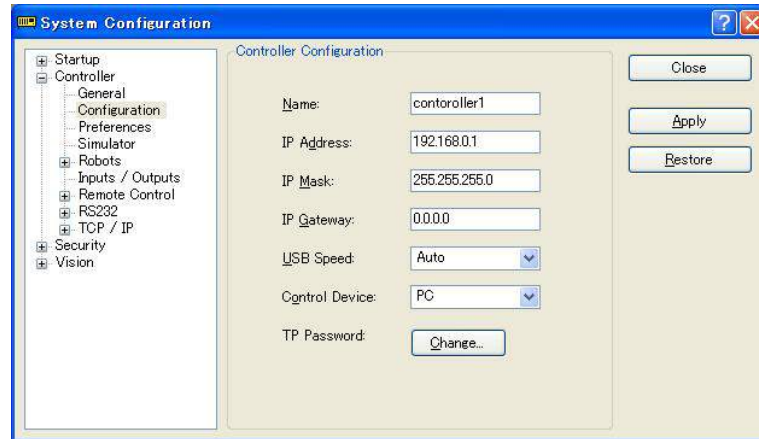

- (3) Select [Controller]-[Configuration].

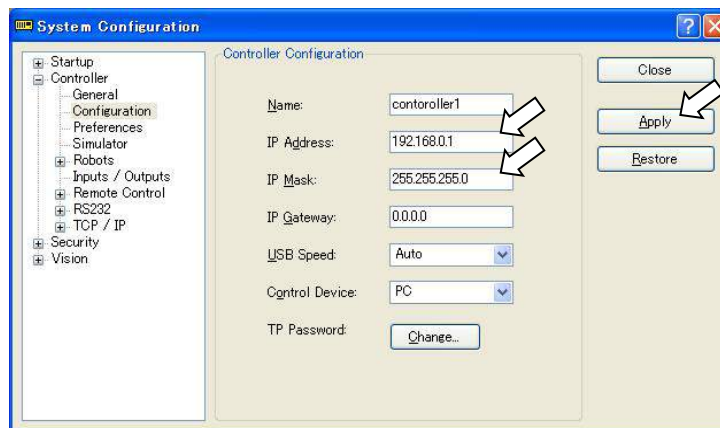

- (4) Enter the proper IP address and subnet mask and click the <Apply> button.
- (5) Click the <Close> button. The Manipulator reboots automatically.  
IP address configuration is completed and the Manipulator reboot dialog disappears.



When the Manipulator and the development PC are connected via the Ethernet, the Manipulator IP address can also be changed. However, Manipulator and the development PC do not connect automatically after rebooting the Manipulator at Ethernet connection.

## 9.4 Connection of Development PC and Manipulator with Ethernet

Connection between the development PC and the Manipulator is shown below.

- (1) Connect the development PC and the Manipulator using the Ethernet cable.
- (2) Turn on the Manipulator.
- (3) Start EPSON RC+ 7.0.
- (4) Display the [PC to Controller Communication] dialog from [Setup] in EPSON RC+ 7.0 menu.
- (5) Click the <Add> button.

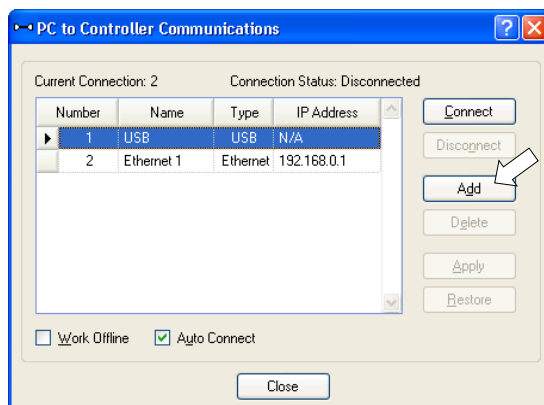

- (6) Connection “No.2” is added. Set the following and click the <Apply> button.  
 Name : Valid value to identify the Manipulator to connect  
 IP Address : IP address for Manipulator to connect

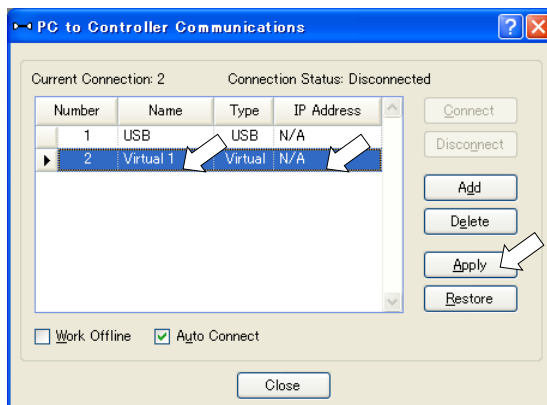

- (7) [Name] and [IP Address] specified in procedure (6) is displayed.

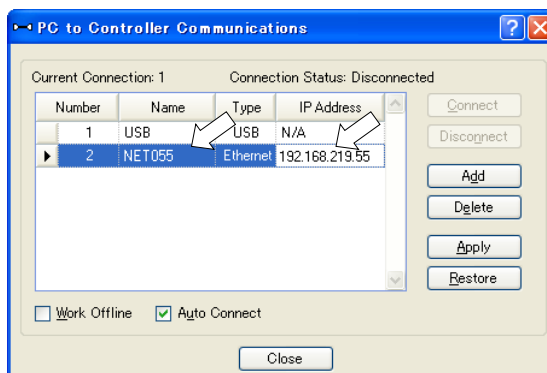

- (8) Make sure that “No.2” is selected, and click the <Connect> button.

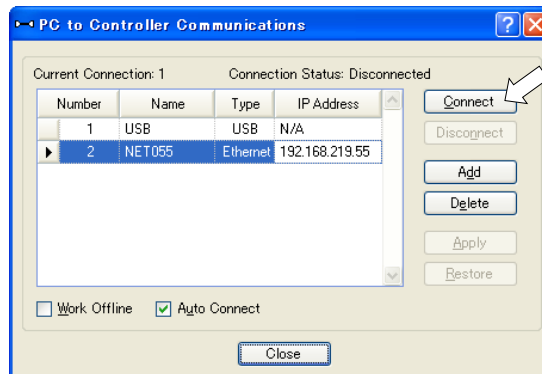

- (9) After the development PC and Manipulator connection is completed, “Connected” is displayed in the [Connection status:]. Make sure that “Connected” is displayed and click the <Close> button to close the [PC to Controller Communications] dialog.

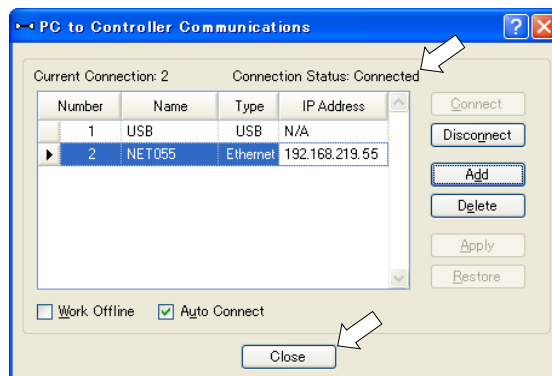

Connection between the development PC and the Manipulator is complete. Now the robot system can be used via an Ethernet connection from EPSON RC+ 7.0.

## 9.5 Disconnection of Development PC and Manipulator with Ethernet

Disconnection of the development PC and the Manipulator is shown below.

- (1) Display [PC-Controller Connection] dialog from [Setup] in EPSON RC+ 7.0 menu.
- (2) Click the <Disconnect> button.

Communication between the Manipulator and the development PC is disconnected and the Ethernet cable can be removed.



If the Ethernet cable is removed when the Manipulator and the development PC is connected, Emergency Stop occurs and the Manipulator stops. Be sure to click the <Disconnect> button in the [PC to Controller Communications] dialog before the Ethernet cable is removed.

## 10. TP Port

### 10.1 What is the TP Port?

The TP port connects the Teach Pendant to the manipulator. You can connect the Teach Pendant (TP2, TP3).

Dedicated convert cable\* is necessary if connecting TP2 to T series manipulator. Contact to regional office if only convert cable is necessary.

\* TP Exchange Cable: R12NZ900L6



When nothing is connected to the TP port, Emergency Stop status occurs in the Manipulator. When the Teach Pendant is not connected, connect the TP bypass plug.

Do not connect the devices except TP2, TP3 to the TP port. Connecting these devices may result in malfunction of the device since the pin assignments are different.

### 10.2 Teach Pendant Connection

A dedicated cable is attached to the Teach Pendant. Connect this cable connector to the TP port.

Communication is set automatically. Enable the Teach Pendant by one of the following procedures.

- Insert the Teach Pendant connector to the Manipulator and turn ON the Manipulator.
- Insert the Teach Pendant connector while the Manipulator is turned ON.



Teach Pendant connection and disconnection from the Controller are allowed when the Manipulator power is ON.

When the Teach Pendant connector is removed from the Manipulator with the mode selector key switch of the Teach Pendant in the “Teach” position, the operation mode will remain in the TEACH mode. The operation mode cannot be switched to AUTO mode. Be sure to remove the Teach Pendant after switching the operation mode to “Auto” mode.

For details, refer to manual

*Robot Controller RC700/RC90 Option Teach Pendant TP2.*

*Robot Controller RC700-A Option Teach Pendant TP3.*

# 11. EMERGENCY

**NOTE**  The details of safety requirements for this section are described in *EPSON RC+ 7.0 User's Guide 2. Safety*. Please refer to them to keep the robot system safe.

 <b>WARNING</b>	<ul style="list-style-type: none"> <li>■ Make sure that emergency stop or safeguard operate properly before operating, not only booting but also usage changed such as options added or parts replaced as maintenance.</li> <li>■ Before connecting the connector, make sure that the pins are not bent. Connecting with the pins bent may damage the connector and result in malfunction of the robot system.</li> </ul>
---	---

Connect a safeguard switch or Emergency Stop switch to the EMERGENCY connector for safety.  
 When nothing is connected to the EMERGENCY connector, the robot system does not operate normally.

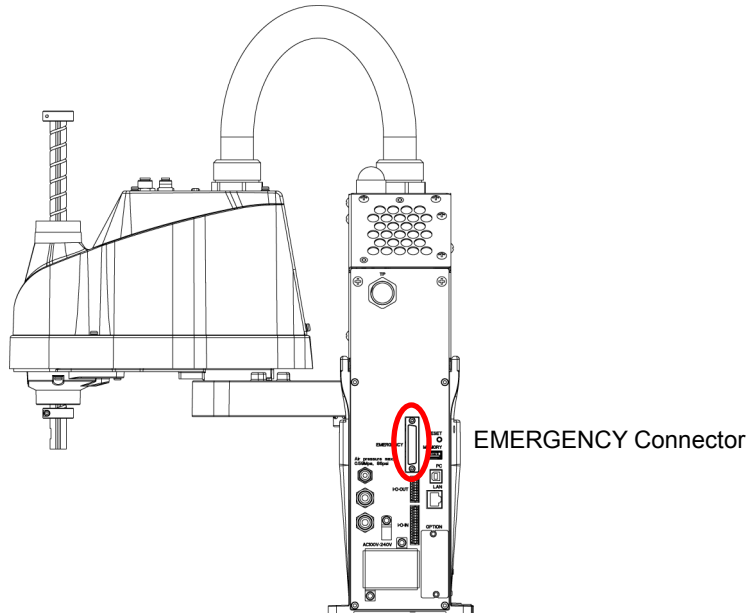

(Illustration: T3-401S)

## 11.1 Safeguard Switch and Latch Release Switch

The EMERGENCY connector has input terminals for the Safeguard switch and the Emergency Stop switch. Be sure to use these input terminals to keep the system safe.

Connector	Standard
EMERGENCY connector (Manipulator side)	D-Sub 25 pin female (cable side) D-Sub 25 pin male (board side)

\* The E-STOP BOX, EMERGENCY connector cable, terminal block, and EMERGENCY connector kit are offered as options.

**11.1.1 Safeguard Switch**

 WARNING	<ul style="list-style-type: none"> <li>■ The interlock of the Safeguard must be functioning when the robot system is operated. Do not operate the system under the condition that the switch cannot be turned ON/OFF (e.g. The tape is put around the switch.). Operating the robot system when the switch is not functioning properly is extremely hazardous and may cause serious safety problems as the Safeguard input cannot fulfill its intended function.</li> </ul>
--	---

In order to maintain a safe working zone, a safeguard must be erected around the Manipulator. The safeguard must have an interlock switch at the entrance to the working zone. The Safeguard that is described in this manual is one of the safeguards and an interlock of the Safeguard is called a Safeguard switch. Connect the Safeguard switch to the Safeguard input terminal on the EMERGENCY connector.

The Safeguard switch has safety features such as temporary hold-up of the program or the operation-prohibited status that are activated whenever the Safeguard is opened.

Observe the following in designing the Safeguard switch and the Safeguard.

- For the Safeguard switch, select a switch that opens as the Safeguard opens, and not by the spring of the switch itself.
- The signal from the Safeguard (Safeguard input) is designed to input to two redundant signals. If the signals at the two inputs differ by two seconds or more, the system recognizes it to be a critical error. Therefore, make sure that the Safeguard switch has two separate redundant circuits and that each connects to the specified pins at the EMERGENCY connector on the Controller.
- Make sure to design the safeguard to prevent the door from closing accidentally.

**11.1.2 Latch Release Switch**

The controller software latches these conditions:

- The safeguard is open.
- The operation mode is set to “TEACH”.

The EMERGENCY connector has an input terminal for a latch release switch that cancels the latched conditions.

Open : The latch release switch latches conditions that the safeguard is open or the operation mode is “TEACH”.

Closed : The latch release switch releases the latched conditions.



When the latched TEACH mode is released while the safeguard is open, the status of Manipulator power is operation-prohibited because the safeguard is open at that time. To execute a Manipulator operation, close the safeguard again, and then close the latch release input.

### 11.1.3 Checking Latch Release Switch Operation

After connecting the safeguard switch and latch release switch to the EMERGENCY connector, be sure to check the switch operation for safety by following the procedures described below before operating the Manipulator.

- (1) Turn ON the Controller while the safeguard is open in order to boot the controller software.
- (2) Make sure that “Safety” is displayed on the main window status bar.
- (3) Close the safeguard, and turn ON the switch connecting to the latch release input. Make sure that the “Safety” is dimmed on the status bar.

The information that the safeguard is open can be latched by software based on the latch release input condition.

Open : The latch release switch latches the condition that the safeguard is open.  
To cancel the condition, close the safeguard, and then close the safeguard latch release input.

Closed : The latch release switch does not latch the condition that the safeguard is open.



The latch release input also functions to acknowledge the change of to TEACH mode. In order to change the latched condition of TEACH mode, turn the mode selector key switch on the Teach Pendant to “Auto”. Then, close the latch release input.

## 11.2 Emergency Stop Switch Connection

### 11.2.1 Emergency Stop Switch

If it is desired to add an external Emergency Stop switch(es) in addition to the Emergency Stop on the Teach Pendant and Operator Panel, be sure to connect such Emergency Stop switch(es) to the Emergency Stop input terminal on the EMERGENCY connector.

The Emergency Stop switch connected must comply with the following and related safety standard (IEC60947-5-5, etc.):

- It must be a push button switch that is “normally closed”.
- A button that does not automatically return or resume.
- The button must be mushroom-shaped and red.
- The button must have a double contact that is “normally closed”.



The signal from the Emergency Stop switch is designed to use two redundant circuits. If the signals at the two circuits differ by two seconds or more, the system recognizes it as a critical error. Therefore, make sure that the Emergency Stop switch has double contacts and that each circuit connects to the specified pins on the EMERGENCY connector at the Controller. Refer to the *Setup & Operation 11.4 Circuit Diagrams*.

### 11.2.2 Checking Emergency Stop Switch Operation

Once the Emergency Stop switch is connected to the EMERGENCY connector, continue the following procedure to make sure that the switch functions properly. For the safety of the operator, the Manipulator must not be powered ON until the following test is completed.

- (1) Turn ON the Manipulator to boot the controller software while pressing the Emergency Stop switch.
- (2) Make sure that E-STOP LED of the Manipulator is lighting.
- (3) Make sure that “E.Stop” is displayed on the status bar on the main window.
- (4) Release the Emergency Stop Switch.
- (5) Execute the RESET command.
- (6) Make sure that E-STOP LED is turned OFF and that “E-Stop” is dimmed on the main window status bar.

### 11.2.3 Recovery from Emergency Stop

To recover from the emergency stop condition, follow the procedure of safety check as required by the system.

After safety check, the operations below are required to recover from the emergency stop condition.

- Release the Emergency Stop Switch
- Execute the RESET command



## 11.3 Pin Assignments

The EMERGENCY connector pin assignments are as follows: (D-Sub 25 pin male)

Pin No.	Signal	Function	Pin No.	Signal	Function
1	ESW11	Emergency Stop switch contact (1) <sup>*3</sup>	14	ESW21	Emergency Stop switch contact (2) <sup>*3</sup>
2	ESW12	Emergency Stop switch contact (1) <sup>*3</sup>	15	ESW22	Emergency Stop switch contact (2) <sup>*3</sup>
3	ESTOP1+	Emergency Stop circuit 1 (+) <sup>*4</sup>	16	ESTOP2+	Emergency Stop circuit 2 (+) <sup>*4</sup>
4	ESTOP1-	Emergency Stop circuit 1 (-) <sup>*4</sup>	17	ESTOP2-	Emergency Stop circuit 2 (-) <sup>*4</sup>
5	Not Used	<sup>*1</sup>	18	SDLATCH1	Safeguard Latch Release
6	Not Used	<sup>*1</sup>	19	SDLATCH2	Safeguard Latch Release
7	SD11	Safeguard input (1) <sup>*2</sup>	20	SD21	Safeguard input (2) <sup>*2</sup>
8	SD12	Safeguard input (1) <sup>*2</sup>	21	SD22	Safeguard input (2) <sup>*2</sup>
9	24V	+24V output	22	24V	+24V output
10	24V	+24V output	23	24V	+24V output
11	24VGND	+24V GND output	24	24VGND	+24V GND output
12	24VGND	+24V GND output	25	24VGND	+24V GND output
13	Not Used	<sup>*1</sup>			

<sup>\*1</sup> Do not connect anything to these pins.

<sup>\*2</sup> A critical error occurs if the input values from the Safeguard 1 and Safeguard 2 are different for two or more seconds. They must be connected to the same switch with two sets of contacts.

<sup>\*3</sup> A critical error occurs if the input values from the Emergency Stop switch contact 1 and Emergency Stop switch contact 2 are different for two or more seconds. They must be connected the same switch with two sets of contacts.

<sup>\*4</sup> Do not apply reverse voltage to the Emergency Stop circuit.

Emergency Stop switch output rated load	+30 V 0.3 A or under	1-2, 14-15 pin
Emergency Stop rated input voltage range	+24 V $\pm 10\%$	3-4, 16-17 pin
Emergency Stop rated input current	37.5 mA $\pm 10\%$ /+24 V input	
Safeguard rated input voltage range	+24 V $\pm 10\%$	7-8, 20-21 pin
Safeguard rated input current	10 mA/+24 V input	
Latch Release rated input voltage range	+24 V $\pm 10\%$	18-19 pin
Latch Release rated input current	10 mA/+24 V input	



The total electrical resistance of the Emergency Stop switches and their circuit should be 1  $\Omega$  or less.



CAUTION

- The 24 V output is for emergency stop. Do not use it for other purposes. Doing so may result in system malfunction.
- Do not apply reverse voltage to the Emergency Stop circuit. Doing so may result in system malfunction.

### 11.4 Circuit Diagrams

#### 11.4.1 Example 1: External emergency stop switch typical application

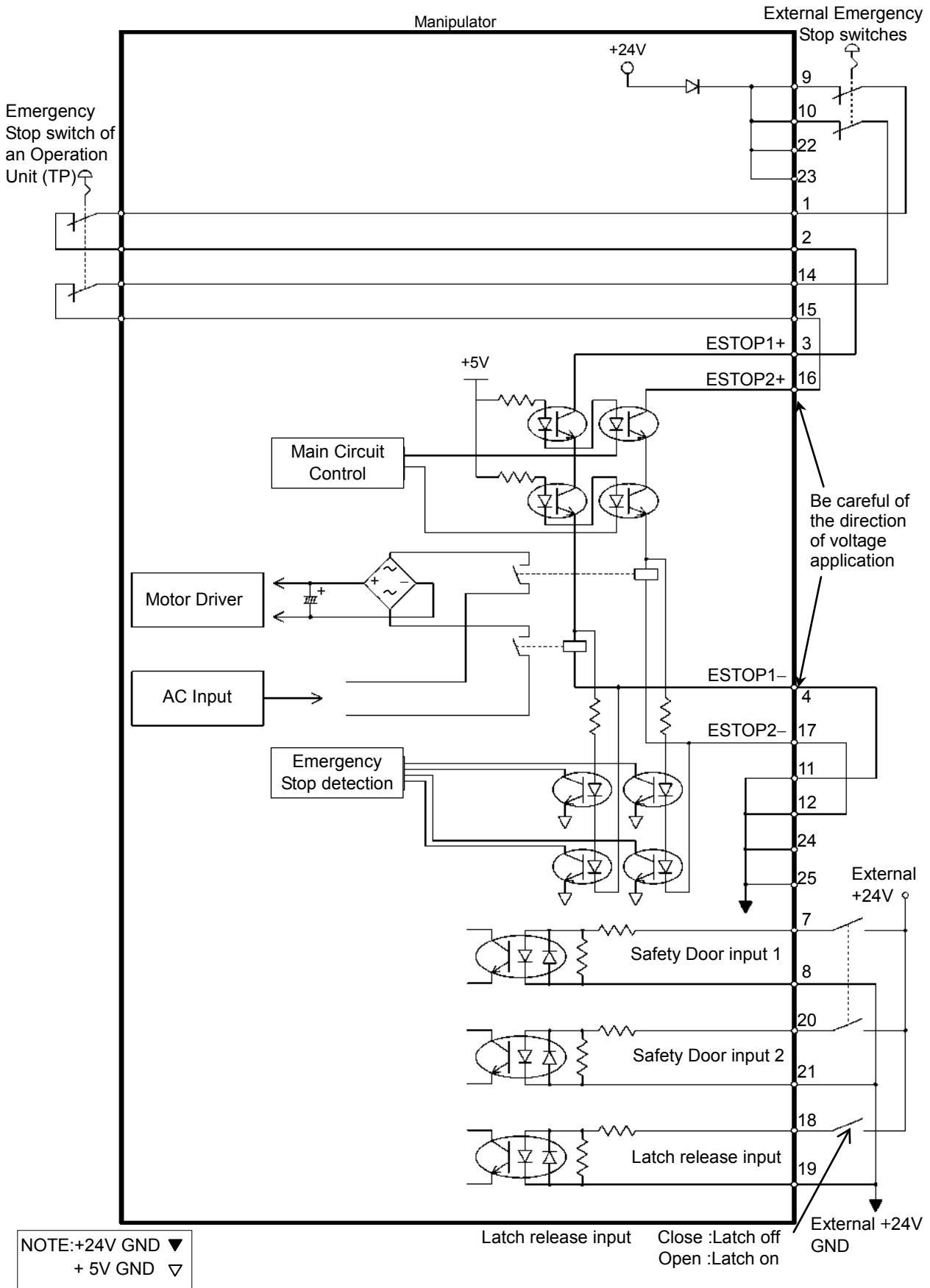

11.4.2 Example 2: External safety relay typical application

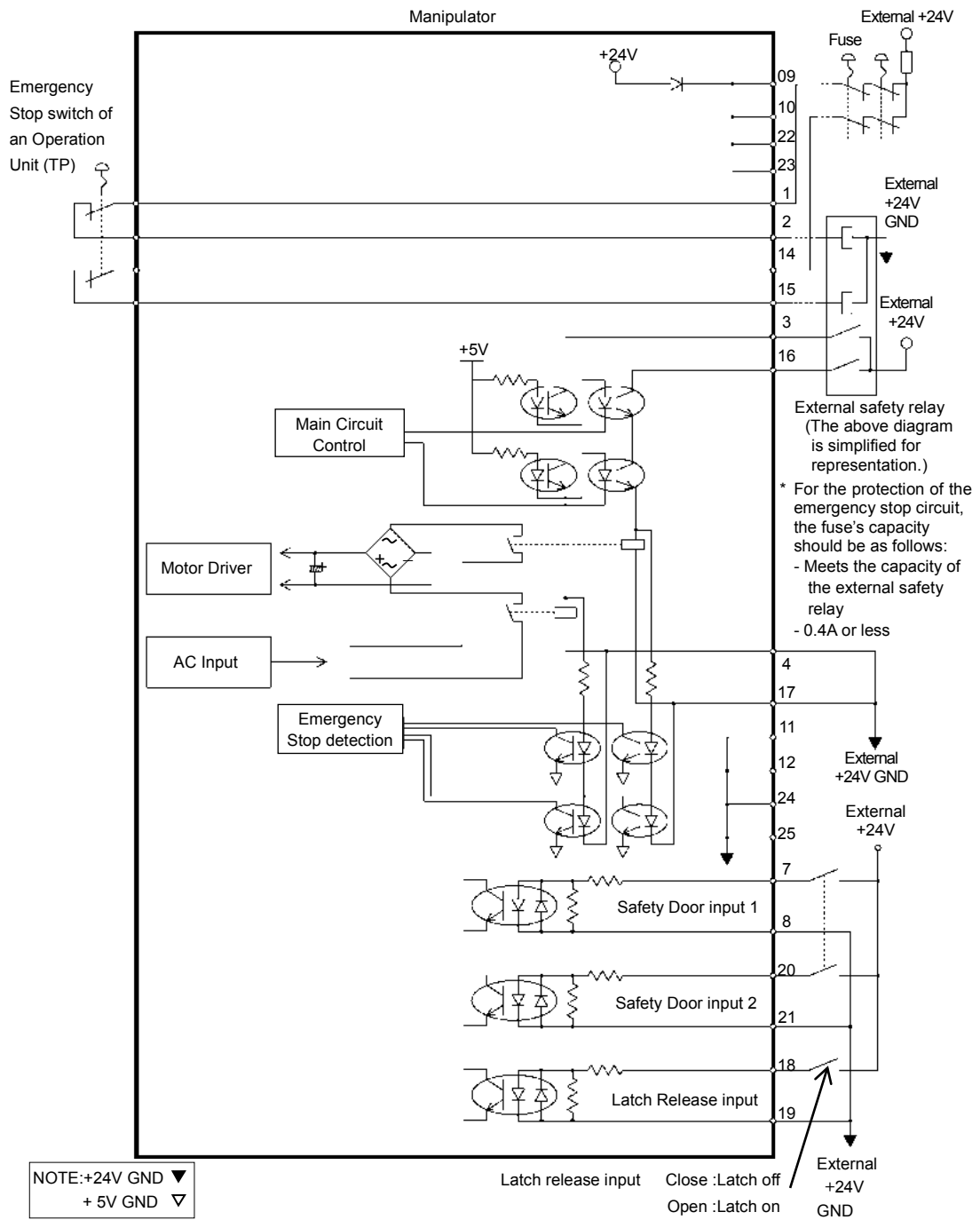

## 12. Standard I/O Connector



CAUTION

- Be careful not to exceed rated current range or rated current which are defined in manual.  
If exceeding rated current, the Manipulator may now operate at worst.

Standard I/O Connector is a connector mounted on back side of the Manipulator for connecting your input/output equipment to the system.

Connector name	Pins	Bit number
I/O (Input) Connector	18	0-17
I/O (Output) Connector	12	0-11

For cable wiring, refer to the *Setup & Operation 3.7.2 Noise Countermeasures* in order to prevent noise.

Remote function is initially assigned to both input and output from 0 to 7. For further details, refer to *Setup & Operation 14. I/O Remote Settings*.

Also, for details of hand I/O, refer to the *Setup & Operation 13.Hand I/O Connector*

### 12.1 Input Circuit

Input Voltage Range	: +12 to 24 V $\pm$ 10%
ON Voltage	: +10.8 V (min.)
OFF Voltage	: +5 V (max.)
Input Current	: 10 mA (TYP) at +24 V input

Two types of wiring are available for use with the two-way photo coupler in the input circuit.

### 12.1.1 Typical Input Circuit Application

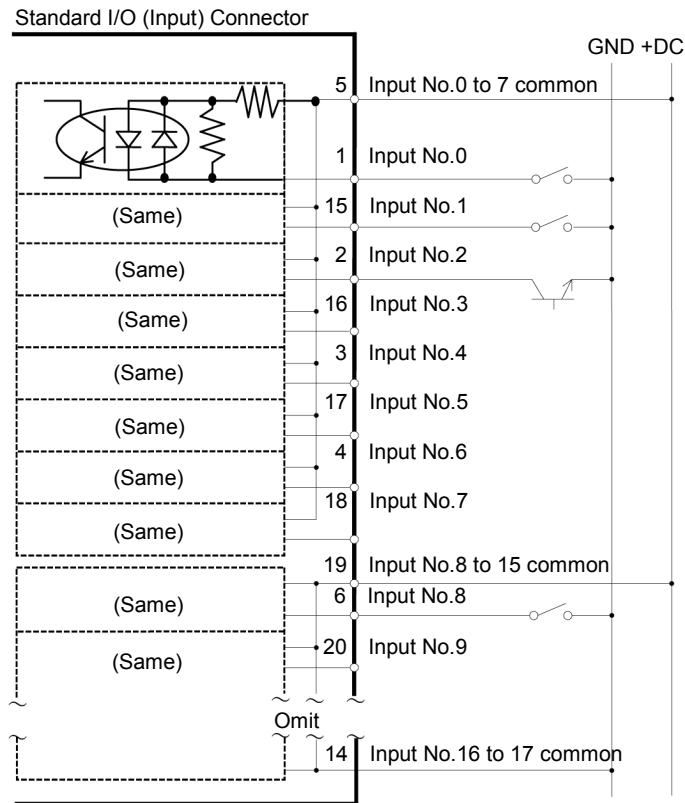

### 12.1.2 Typical Input Circuit Application 2

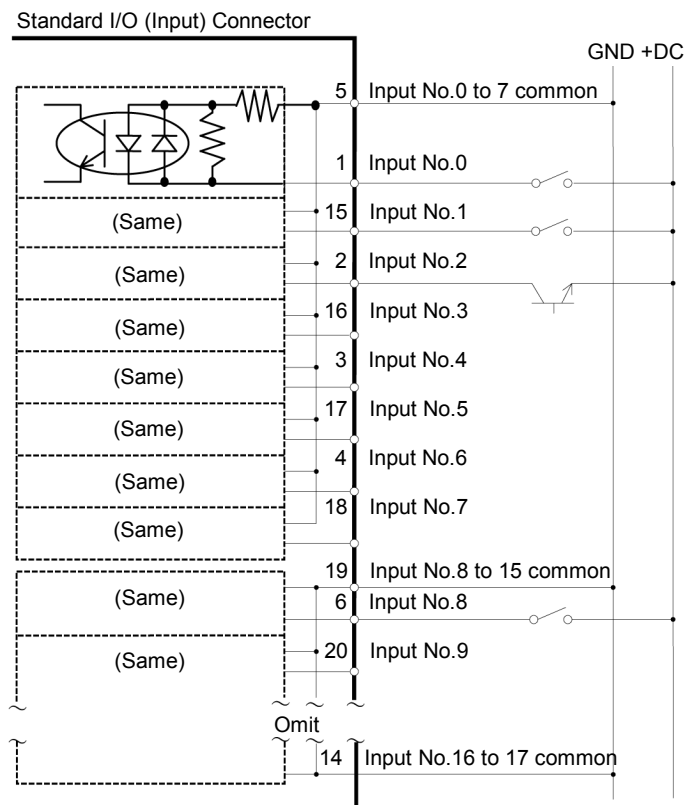

### 12.1.3 Pin Assignments of Input Circuit

Pin No.	Signal Name	Pin No.	Signal Name
1	Input No. 0 (Start)	15	Input No. 1 (SelProg1)
2	Input No. 2 (SelProg2)	16	Input No. 3 (SelProg4)
3	Input No. 4 (Stop)	17	Input No. 5 (Pause)
4	Input No. 6 (Continue)	18	Input No. 7 (Reset)
5	Input common No. 0 to 7	19	Input common No. 8 to 15
6	Input No. 8	20	Input No. 9
7	Input No. 10	21	Input No. 11
8	Input No. 12	22	Input No. 13
9	Input No. 14	23	Input No. 15
10	Input No. 16	24	Input No. 17
11	Not Used	25	Not Used
12	Not Used	26	Not Used
13	Not Used	27	Not Used
14	Input common No. 16 to 17	28	Not Used

Remote function inside ( ) in the table above is initially assigned to input from 0 to 7. For further details, refer to *Setup & Operation 14. I/O Remote Settings*.

Connector	Connector model
I/O (Input) Connector	DMC 0,5/14-G1-2,54 P20THR R72 (Board side) DFMC 0,5/14-ST-2,54 (Cable side) (PHOENIX CONTACT)

\* I/O connector is included with shipment.

I/O (Input) Connector pin assignment

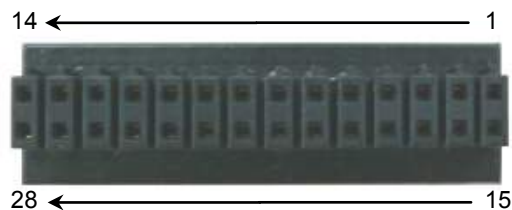

## 12.2 Output Circuit

Rated Output Voltage : +12 V to +24 V  $\pm 10\%$

Maximum Output Current : TYP 100 mA/1 output

Output device : PhotoMOS relay

ON resistance : Less than 0.7  $\Omega$

The following two wirings are available since non-polar PhotoMOS relay is used for output circuit.



- Be sure to wire the output circuit properly because it has no protection circuitry for short-circuit and reverse-connection. Improper wiring may cause malfunction of the parts on the board and then improper function of the robot system.

### 12.2.1 Typical Output Circuit Application 1

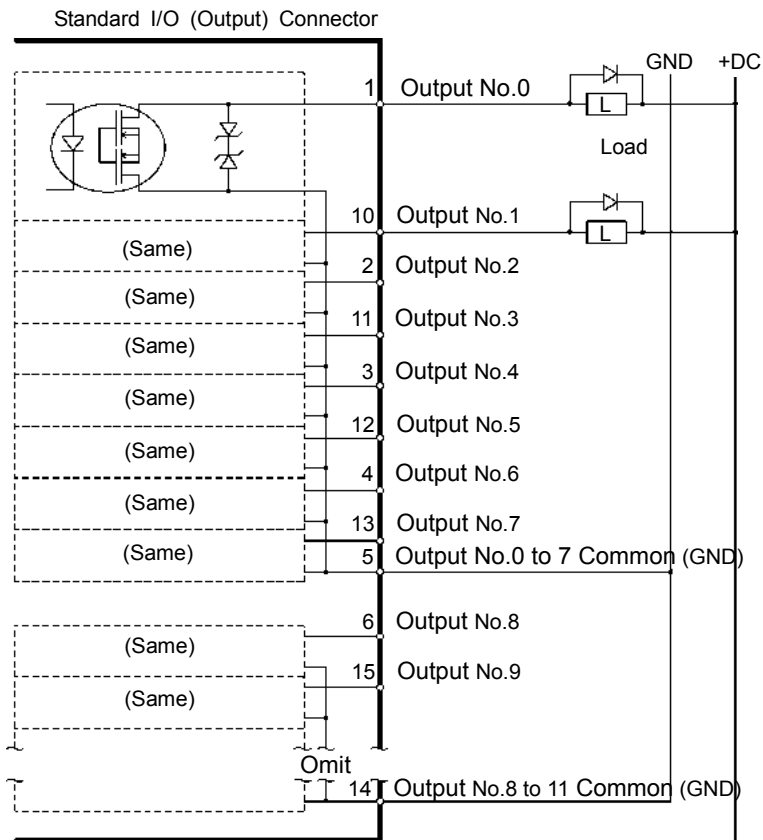

### 12.2.2 Typical Output Circuit Application 2

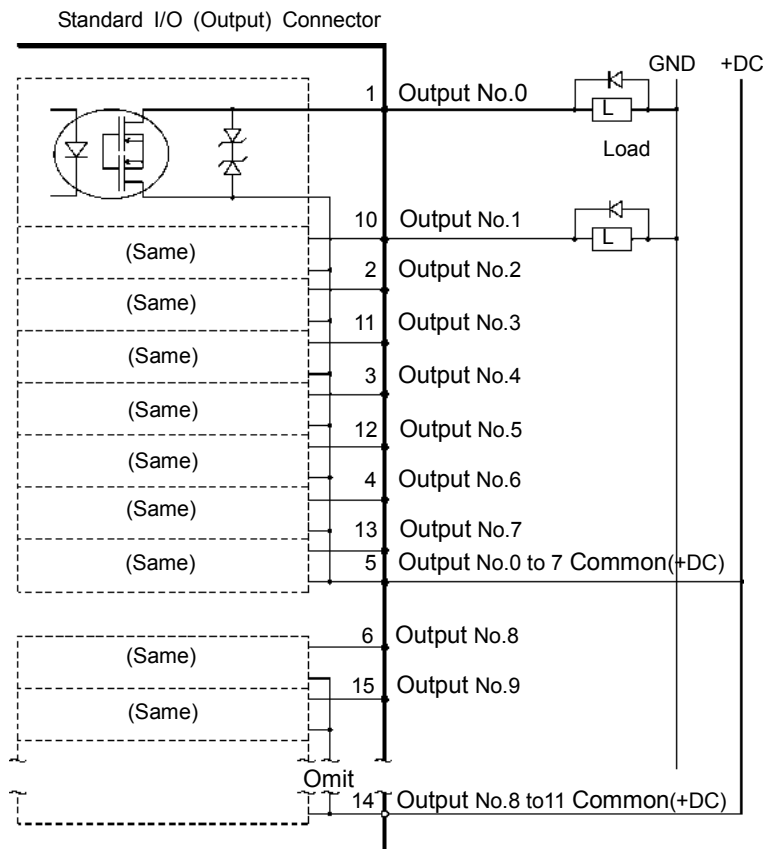

12.2.3 Pin Assignments of Output Circuit

Pin No.	Signal Name	Pin No.	Signal Name
1	Output No. 0 (Ready)	10	Output No.1 (Running)
2	Output No.2 (Paused)	11	Output No.3 (Error)
3	Output No.4 (EstopOn)	12	Output No.5 (SafeguardOn)
4	Output No.6 (SError)	13	Output No.7 (Warning)
5	Output common No. 0 to 7	14	Output common No. 8 to 11
6	Output No. 8	15	Output No. 9
7	Output No.10	16	Output No.11
8	Not Used	17	Not Used
9	Not Used	18	Not Used

Remote function inside ( ) in the table above is initially assigned to output from 0 to 7. For further details, refer to *Setup & Operation 14. I/O Remote Settings*.

Connector	Connector model
I/O (Output) Connector	DMC 0,5/9-G1-2,54 P20THR R44 (Board side) DFMC 0,5/ 9-ST-2,54 (Cable side) (PHOENIX CONTACT)

\* I/O connector is included with shipment.

I/O (Output) Connector pin assignment





## 12.3 I/O Cable Product Procedure

The following describes I/O cable product procedure for connecting user's input/output devices.

### 12.3.1 I/O Cable Connecting Method

- (1) Prepare for I/O connector and cable which are included with shipment.

Adaption cable:

Electric wire capacity: 0.14 to 0.5mm<sup>2</sup>

Wire type: single wire, stranded wire, stranded wire with rod terminal.

- (2) Push the edge of cable into wire insertion slot.

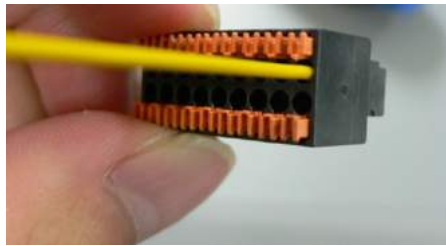

For single wire and stranded wire, peel off the covering of the cable.

NOTE  

- If using a twisted wire or finer single wire, insert it while pushing orange colored open button.
- Orange push pins are easy to come off. Be careful during operation.
- There is a cable check hole above the open button. You can check cables using tester.

### 12.3.2 How to Fix the I/O Cable

You can fix the I/O cables using cable clamp on the back of the manipulator.

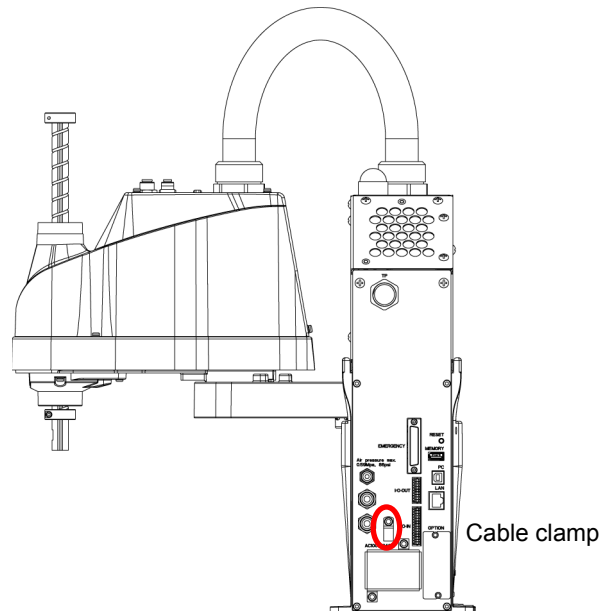

(Illustration: T3-401S)

NOTE  

Fixing cables with I/O cable clamp, wiring of I/O cables is difficult to disconnect.

## 13. Hand I/O Connector



- Be careful not to exceed rated current range or rated current which are defined in manual.  
If exceeding rated current, the Manipulator may now operate at worst.

Hand I/O connector is a connector for connecting your input/output equipment to the system. It is mounted on upper of Arm #2.

Connector name	Polarity	Pins	Bit number
Hand I/O connector	Input	6	18-23
	Output	4	12-15

For cable wiring, refer to the *Setup & Operation 3.7.2 Noise Countermeasures* in order to prevent noise.

Also, for details of standard I/O mounted on back side of the manipulator, refer to the *Setup & Operation 12 Standard. I/O Connector*.

### 13.1 Power Supply Specifications

Hand I/O connector has a power supply which user can use. Enable to use this power supply to operate external devices.

Be careful not to exceed allowable current when using power supply.

- Voltage: 24V ±5%
- Allowable current: T3: 500mA  
T6: 700mA

## 13.2 Input Circuit

Input Voltage Range	: +12 to 24 V $\pm$ 10%
ON Voltage	: +10.8 V (min.)
OFF Voltage	: +5 V (max.)
Input Current	: 10 mA (TYP) at +24 V input

Two types of wiring are available for use with the two-way photo coupler in the input circuit.

### 13.2.1 Typical Input Circuit Application 1

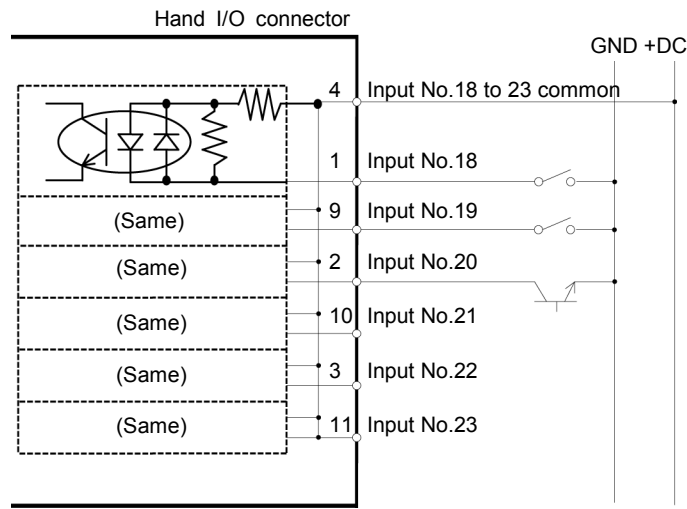

### 13.2.2 Typical Input Circuit Application 2

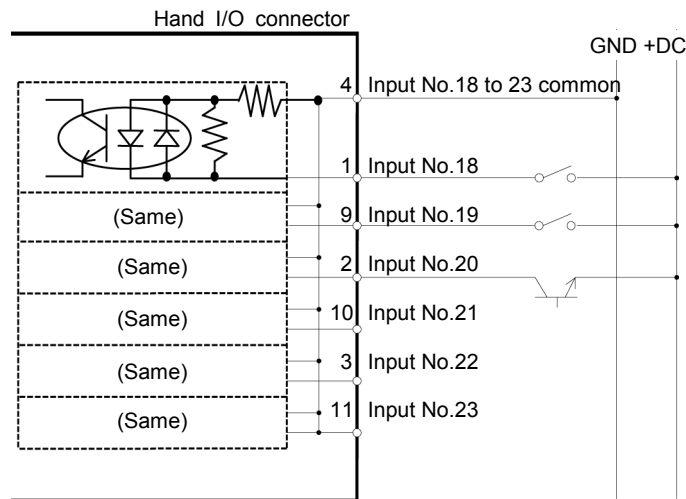

### 13.3 Output Circuit

- Rated Output Voltage : +12 V to +24 V  $\pm$ 10%
- Maximum Output Current : TYP 100 mA/1 output
- Output device : PhotoMOS relay
- On resistance : Less than 0.7  $\Omega$

The following two wirings are available since non-polar PhotoMOS relay is used for output circuit.



- Be sure to wire the output circuit properly because it has no protection circuitry for short-circuit and reverse-connection. Improper wiring may cause malfunction of the parts on the board and then improper function of the robot system.

#### 13.3.1 Typical Output Circuit Application 1

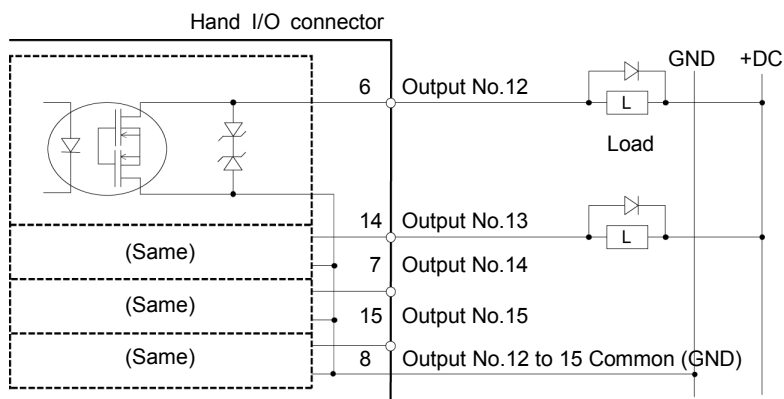

#### 13.3.2 Typical Output Circuit Application 2

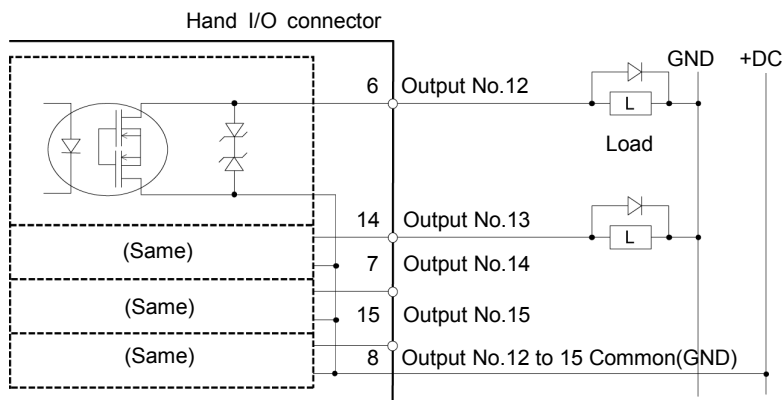

## 13.4 Pin Assignments

The following is pin assignments of Hand I/O connector (D-sub 15 pin male).

Pin No.	Signal Name	Pin No.	Signal Name
1	Input No.18	9	Input No.19
2	Input No.20	10	Input No.21
3	Input No.22	11	Input No.23
4	Input common No.18 to 23	12	Not Used
5	+24V	13	GND
6	Output No.12	14	Output No.13
7	Output No.14	15	Output No.15
8	Output common No.12 to 15		

Connector	Standard
Hand I/O connector	D-Sub 15 pin female (manipulator side) D-Sub 15 pin male (cable side)

\* I/O connector is included with shipment.

## 13.5 How to Control Hand I/O

T series has I/O (Input: 6 bit, Output: 4 bit) for hand control I/O.

Input bit port: 18, 19, 20, 21, 22, 23

Output bit port: 12, 13, 14, 15

### How to operate

Hand I/O is only supported for bit port operation commands. Byte or word commands are not supported.

### Available commands

Command	Function
Sw	Input bit port I/O.
SetSw	Set an input of virtual I/O.
On	Turn ON the output bit.
Off	Turn OFF the output bit.

### Restriction 1: Remote I/O

Hand I/O cannot be set in Remote I/O.

### Restriction 2: Input/Output by byte port or word port

There are restrictions to operate input/output of standard I/O by byte or word port since hand I/O is included in byte port and word port.

Input: Always "0" is read for bit of hand I/O.

Output: Execute error occurs when specifying "1" for bit of hand I/O.

Input example:

When operating byte input by following conditions

Input hand I/O23: ON

Input standard I/O bit: 16=OFF, 17=ON

In (2) ---> 0x02 (0000 0010B)

Output example:

When operating byte output by following conditions

Output standard I/O bit port 11=ON,10~8=OFF

Out 1, 'H08

Error output example:

When operating byte output by following conditions

Output standard I/O bit port 11=ON,10~8=OFF

Out 1, 'H18 <---- Error since hand I/O bit is ON

	Byte port		Word port	
	Port	Description	Port	Description
Input	2	“0” is read for upper 6 bits 0000 00xx	1	“0” is read for upper 6 bits 0000 00xx xxxx xxxx
Output	1	Always specify “0” for upper 4 bits. 0000 xxxx	0	Always specify “0” for upper 4 bits. 0000 xxxx xxxx xxxx

## 14. I/O Remote Settings

This section describes the functions and timings of input and output signals.

The remote functions may be assigned to your standard I/O board(s), or fieldbus I/O board(s) to enhance robot system control - either from an operational unit of your choice or a sequencer.

Remote function is initially assigned to both input and output from 0 to 7.

To accept external remote inputs, assign the remote function and the control device is remote. For further details, refer to the section, *Remote Control Software Configuration* in *EPSON RC+ 7.0 User's Guide - Remote Control*.

The user defines the I/O number that a remote function is assigned to using software configuration. For further details, refer to the section, *Remote Control Software Configuration* in *EPSON RC+ 7.0 User's Guide - Remote Control*.

For details about I/O cable connection, refer to sections on *Setup & Operation 12: Standard I/O Connector*, *13. Hand I/O Connector* and *17. Fieldbus I/O*.

For details about communication with external equipment, refer to *EPSON RC+ 7.0 User's Guide -12. Remote Control*.



- When using remote I/O, always make sure of the following. Using the robot system under unsatisfactory conditions may cause malfunction of the system and/or safety problems.

- Assign remote functions to inputs/outputs correctly and wire correctly when setting up remote I/O signals.
- Make sure that the functions correspond to the correct input/output signals before turning ON the system.

When verifying the robot system operation, prepare for failures with initial settings or wiring. If the Manipulator functions unusually by the failures with initial settings or wiring, press the Emergency Stop switch immediately to stop the Manipulator.



Remote function is available when virtual I/O is enabled.

When you set up a remote I/O signal, please either keep a written record of the settings or store the data in a file for later reference.

When you set up a fieldbus I/O signal to the remote function, response depends on the baud rate of the fieldbus. For details of fieldbus response, refer to *Robot Controller RC700 / RC90 Option Fieldbus I/O*.

Hand I/O connector cannot be set in remote signal.

## 14.1 I/O Signal Description

Remote function is initially assigned to both input and output from 0 to 7.

To change the function assignment from the initial setting, use EPSON RC+ 7.0.

To use all signals, you will need to add Fieldbus I/O module.

### 14.1.1 Remote Input Signals

Remote inputs are used to control the Manipulators and start programs. Certain conditions must be met before inputs are enabled, as shown in the table below.

To accept external remote inputs, assign the remote function and set remote to the control device. When external remote input is available, “AutoMode output” turns ON.

Except “SelProg”, the signals execute each function when the signal starts in input acceptance condition. The function executes automatically. Therefore, no special programming is needed.



When an error occurs, you must execute a “Reset” to clear the error condition before any other remote input commands can be executed. Use the “Error output” and “Reset input” to monitor the error status and clear error conditions from the remote device.

Name	Initial	Description	Input Acceptance Condition (*1)
Start	0	Execute function selected at SelProg. (*2)	Ready output ON Error output OFF EStopOn output OFF SafeguardOn output OFF Pause input OFF Stop input OFF
SelProg1 SelProg2 SelProg4 SelProg8 SelProg16 SelProg32	1 2 3 Not Set Not Set Not Set	Specify the executing Main function number. (*2)	
Stop	4	All tasks and commands are stopped.	
Pause	5	All tasks are paused. (*3)	Running output ON
Continue	6	Continue the paused task.	Paused output ON Pause input OFF Stop input OFF
Reset	7	Reset emergency stop and error. (*4)	Ready output ON
Shutdown	Not set	Terminates the system	
ForcePowerLow (*6)	Not Set	Operates as the forced low power function. The manipulator is operated in the low power mode. Power High control from the command is not accepted. Executes the following according to the manipulator preferences. Stops or temporarily stops all the tasks and commands. (*12)	Any time This input is acceptable even AutoMode output is OFF.
SelRobot	Not Set	Changes the output condition of MotorsOn, AtHome, PowerHigh, and MCalReqd.(*9)	



Name	Initial	Description	Input Acceptance Condition (*1)
SelRobot1 SelRobot2 SelRobot4 SelRobot8 SelRobot16	Not set	Specify the number of manipulator which executes a command. (*5)	
SetMotorsOn	Not set	Turn ON manipulator motors. (*5) (*6)	Ready output ON EStopOn output OFF SafeguardOn output OFF SetMotorOff input OFF
SetMotorsOff	Not set	Turn OFF manipulator motors.	Ready output ON
SetPowerHigh	Not set	Set the manipulator power mode to High (*5)	Ready output ON EStopOn output OFF SafeguardOn output OFF SetPowerLow input OFF
SetPowerLow	Not set	Set the manipulator power mode to Low. (*5)	Ready output ON
Home	Not set	Move the manipulator Arm to the home position defined by the user.	Ready output ON Error output OFF EStopOn output OFF SafeguardOn output OFF MotorsOn output ON Pause input OFF Stop input OFF
MCal	Not set	Execute MCal (*5) (*7)	Ready output ON Error output OFF EStopOn output OFF SafeguardOn output OFF MotorsOn output ON Pause input OFF Stop input OFF
Recover	Not set	After the safeguard is closed, recover to the position where the safeguard is open.	Paused output ON Error output OFF EStopOn output OFF SafeguardOn output OFF RecoverReqd output ON Pause input OFF Stop input OFF
ResetAlarm	Not Set	Cancel the alarm (*11)	
SelAlarm1 SelAlarm2 SelAlarm4 SelAlarm8	Not Set	Specify the alarm number to cancel (*10)	
ALIVE	Not Set	Input signal for alive monitoring of the manipulator. Same signal as the input will be output to ALIVE output. The master equipment can perform alive monitoring of the manipulator by switching the input periodically and checking the output signal.	

(\*1) "AutoMode output" ON is omitted from the table. This is an input acceptance condition for all functions.

(\*2) “Start input” executes Function specified by the following six bits: SelProg 1, 2, 4, 8, 16, and 32.

Function name	SelProg1	SelProg2	SelProg4	SelProg8	SelProg16	SelProg32
Main	0	0	0	0	0	0
Main1	1	0	0	0	0	0
Main2	0	1	0	0	0	0
Main3	1	1	0	0	0	0
⋮						
Main60	0	0	1	1	1	1
Main61	1	0	1	1	1	1
Main62	0	1	1	1	1	1
Main63	1	1	1	1	1	1

0=OFF, 1=ON

- (\*3) “NoPause task” and “NoEmgAbort task” do not pause.  
For details, refer to *EPSON RC+ 7.0 Online Help* or *Pause* in *SPEL+ Language Reference*.
- (\*4) Turns OFF the I/O output and initializes the manipulator parameter.  
For details, refer to *EPSON RC+ 7.0 Online Help* or *Reset* in *SPEL+ Language Reference*.
- (\*5) T series is invalid.
- (\*6) Initializes the manipulator parameter.  
For details, refer to *EPSON RC+ 7.0 Online Help* or *Motor* in *SPEL+ Language Reference*.
- (\*7) For details, refer to *EPSON RC+ 7.0 Online Help* or *MCal* in *SPEL+ Language Reference*.
- (\*8) This is for experienced users only. Make sure that you fully understand the input specification before using.  
CmdRunning output and CmdError output will not change for this input.  
“NoEmgAbort task” will not stop by this input.  
When the input changes from ON to OFF, all tasks and commands will stop.
- (\*9) This function changes the output condition of MotorsOn, AtHome, PowerHigh, and MCalReqd.  
By setting this signal with the condition selected using SelRobot1 - SelRobot16, you can switch the output condition.  
Once you select the condition, it will be kept until you change it or turn off / restart the Controller. All manipulators are selected as default.

(\*10) The values specified by “SelAlarm1, 2, 4, and 8” correspond to the alarm numbers.

Alarm #	Target	SelAlarm1	SelAlarm2	SelAlarm4	SelAlarm8
1	Controller battery	1	0	0	0
2	-	0	1	0	0
3	Manipulator grease	1	1	0	0
4	-	0	0	1	0
5	-	1	0	1	0
6	-	0	1	1	0
7	-	1	1	1	0
8	-	0	0	0	1
9	-	1	0	0	1

0=OFF, 1=ON

The following parts are subject to grease up.

Ball screw spline unit on the Joint # 3

(\*11) The specified alarm can be canceled by selecting the conditions using SelAlarm1-SelAlarm8 and setting this signal.

(\*12) Operation of all tasks and commands, power mode of the manipulator, and PowerHigh command by the setting of the manipulator preferences.

Preferences (1): “Motor power low when ForcePowerLow signal OFF”

Preferences (2): “ForcePowerLow signal change pauses all tasks”

For details of the manipulator preferences, refer to *EPSON RC+ 7.0 User's Guide [Setup]-[System Configuration]-[Controller]-[Preferences]* in 5.12.2 *[System Configuration] Command (Setup Menu)*.

Preferences (1)	Preferences (2)	ForcePowerLow	All tasks and commands	Power mode	PowerHigh
0	0	1→0	Stop	Low only	Accept
0	0	0→1	Stop	Low only	Not accept
0	1	1→0	Continue	High/Low	Accept
0	1	0→1	Temp. stop	Low only	Not accept
1	0	1→0	Stop	Low only	Not accept
1	0	0→1	Stop	Low only	Accept
1	1	1→0	Temp. stop	Low only	Not accept
1	1	0→1	Continue	High/Low	Accept

### 14.1.2 Remote Output Signals

Remote output is a function to output a status of the Manipulator or operation mode.

Remote outputs provide the assigned function using with any control device. The outputs execute automatically. Therefore, no special programming is needed.

Name	Initial	Description
Ready	0	Turns ON when the manipulator startup completes and no task is running.
Running	1	Turns ON when task is running. However, turns OFF when “Paused output” is OFF.
Paused	2	Turns ON when pause task exists.
Error	3	Turns ON when an error occurs. Use “Reset input” to recover from the error.
EStopOn	4	Turns ON at Emergency Stop.
SafeguardOn	5	Turns ON when the safeguard is open.
SError	6	Turns ON when critical error occurs. When a critical error occurs, “Reset input” does not function. Reboot the controller to recover.
Warning	7	Turns ON when warning occurs. The task runs as normal with the warning. However, be sure to eliminate the cause of the warning as soon as possible.
MotorsOn	Not set	Turns ON when the manipulator motor is ON. (*5)
AtHome	Not set	Turns ON when the manipulator is in the home position. (*5)
PowerHigh	Not set	Turns ON when the manipulator’s power mode is High. (*5)
MCalReqd	Not set	Turns ON when the manipulator hasn’t executed MCal. (*5)
RecoverReqd	Not set	Turns ON when at least one manipulator is waiting for Recover after the safeguard is closed.
RecoverInCycle	Not set	Turns ON when at least one manipulator is executing Recover.
CmdRunning	Not set	Turns ON when an input command is executing.
CmdError	Not set	Turns ON when an input command cannot be accepted.
CurrProg1 CurrProg2 CurrProg4 CurrProg8 CurrProg16 CurrProg32	Not set	Indicates the running or the last main function number (*1)
AutoMode	Not set	Turns ON in remote input acceptable status. (*2)
TeachMode	Not set	Turns ON in TEACH mode.
ErrorCode1 ⋮ ErrorCode8192	Not set	Indicates the error number.
InsideBox1 ⋮ InsideBox15	Not set	Turns ON when the manipulator is in the approach check area. (*3)

Name	Initial	Description
InsidePlane1 ⋮ InsidePlane15	Not set	Turns ON when the manipulator is in the approach check plane. (*4)
Alarm	Not set	Turns ON when any of the alarms is occurring. (*9)
Alarm1	Not set	Turns ON when a battery alarm of the manipulator is occurring.
Alarm2	Not set	Turns ON when a battery alarm of the manipulator connected to CU is occurring.
Alarm3	Not set	Turns ON when a grease alarm of the manipulator connected to CU is occurring. (*10)
Alarm4	Not set	Turns ON when a battery alarm of the manipulator connected to DU1 is occurring.
Alarm5	Not set	Turns ON when a grease alarm of the manipulator connected to DU1 is occurring. (*10)
Alarm6	Not set	Turns ON when a battery alarm of the manipulator connected to DU2 is occurring.
Alarm7	Not set	Turns ON when a grease alarm of the manipulator connected to DU2 is occurring. (*10)
Alarm8	Not set	Turns ON when a battery alarm of the manipulator connected to DU3 is occurring.
Alarm9	Not set	Turns ON when a grease alarm of the manipulator connected to DU3 is occurring. (*10)
PositionX	Not set	Outputs current X coordinate in the World coordinate system (*6) (*7)
PositionY	Not set	Outputs current Y coordinate in the World coordinate system (*6) (*7)
PositionZ	Not set	Outputs current Z coordinate in the World coordinate system (*6) (*7)
PositionU	Not set	Outputs current U coordinate in the World coordinate system (*6) (*7)
PositionV	Not set	Outputs current V coordinate in the World coordinate system (*6) (*7)
PositionW	Not set	Outputs current W coordinate in the World coordinate system (*6) (*7)
Torque1	Not set	Outputs the current torque value of Joint #1 (*6) (*7)
Torque2	Not set	Outputs the current torque value of Joint #2 (*6) (*7)
Torque3	Not set	Outputs the current torque value of Joint #3 (*6) (*7)
Torque4	Not set	Outputs the current torque value of Joint #4 (*6) (*7)
Torque5	Not set	Outputs the current torque value of Joint #5 (*6) (*7)
Torque6	Not set	Outputs the current torque value of Joint #6 (*6) (*7)
CPU	Not set	Outputs the CPU load factor of the user program (*8)
ESTOP	Not set	Outputs how many times emergency stops have been executed.
ALIVE	Not set	Output signal for alive monitoring of the manipulator. The signal input by ALIVE input will be output. The master equipment can perform alive monitoring of the manipulator by switching the input periodically and checking the output signal.

(\*1) Outputs the current or the last function number of CurrProg1, 2, 4, 8, 16, or 32.

Function name	CurrProg1	CurrProg2	CurrProg4	CurrProg8	CurrProg16	CurrProg32
Main	0	0	0	0	0	0
Main1	1	0	0	0	0	0
Main2	0	1	0	0	0	0
Main3	1	1	0	0	0	0
⋮						
Main60	0	0	1	1	1	1
Main61	1	0	1	1	1	1
Main62	0	1	1	1	1	1
Main63	1	1	1	1	1	1

0=OFF, 1=ON

(\*2) Remote function is available in the following conditions.

- The setting is Auto mode and the control device is remote.
- The setting is Program mode and Remote I/O is enabled.

(\*3) For details, refer to *EPSON RC+ 7.0 Online Help* or *Box* in *SPEL+ Language Reference*.

(\*4) For details, refer to *EPSON RC+ 7.0 Online Help* or *Plane* in *SPEL+ Language Reference*.

(\*5) Manipulator status is output as follows, according to the condition selected in SelRobot.

Wait at least 40 ms before inputting the signal after changing the condition in SelRobot.

Name	(SelRobot1- SelRobot16) condition when inputting SelRobot	
	0: All robots are selected	1 - 16: Particular robot number is selected
MotorsOn	Turns ON when at least one manipulator motor is ON.	Turns ON when the motor of the selected manipulator is ON.
AtHome	Turns ON when all manipulators are in the home position.	Turns ON when the selected manipulator is in the home position.
PowerHigh	Turns ON when at least one manipulator's power mode is High.	Turns ON when the selected manipulator's power mode is High.
MCalReqd	Turns ON when at least one manipulator hasn't executed MCal.	Turns ON when the selected manipulator hasn't executed MCal.

(\*6) T series is invalid.

(\*7) Outputs information in Real format.

(\*8) Outputs the total load factor of the user created tasks. For details on the CPU load factor, refer to the task manager.

(\*9) The signal turns on when the alarm occurs in the manipulator alarm information.

(\*10) The following parts are subject to grease up.

Ball screw spline unit on the Joint # 3

## 14.2 Timing Specifications

### 14.2.1 Precautions for Remote Input Signals

The following charts indicate the timing sequences for the primary operations of the Controller.

The indicated time lapses (time durations) should be referred to only as reference values since the actual timing values vary depending on the number of tasks running, as well as CPU speed of the Manipulator. Check carefully and refer to the following charts for the timing interrelation when you enter an input signal.

During system design, make sure that you actuate only one remote input operation at a time, otherwise an error will occur.

The pulse width of an input signal must be 25 or more milliseconds to be detected.

[Unit: ms]

### 14.2.2 Timing Diagram for Operation Execution Sequence

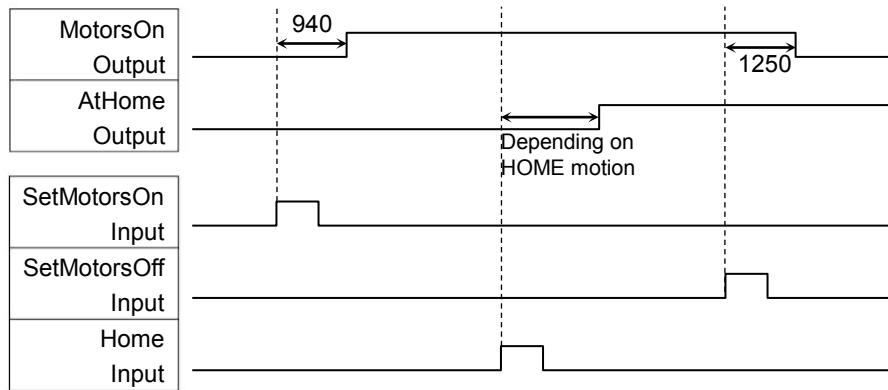

### 14.2.3 Timing Diagram for Program Execution Sequence

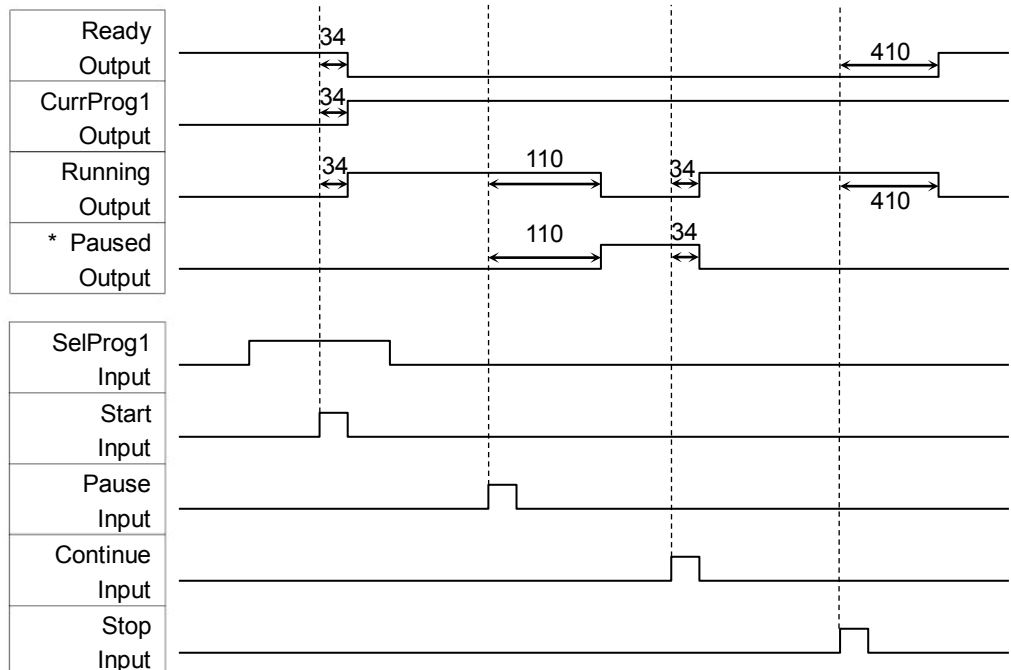

\* The duration varies depending on the Quick Pause (QP) setting and the program's operating status at the time of Pause input

### 14.2.4 Timing Diagram for Safety Door Input Sequence

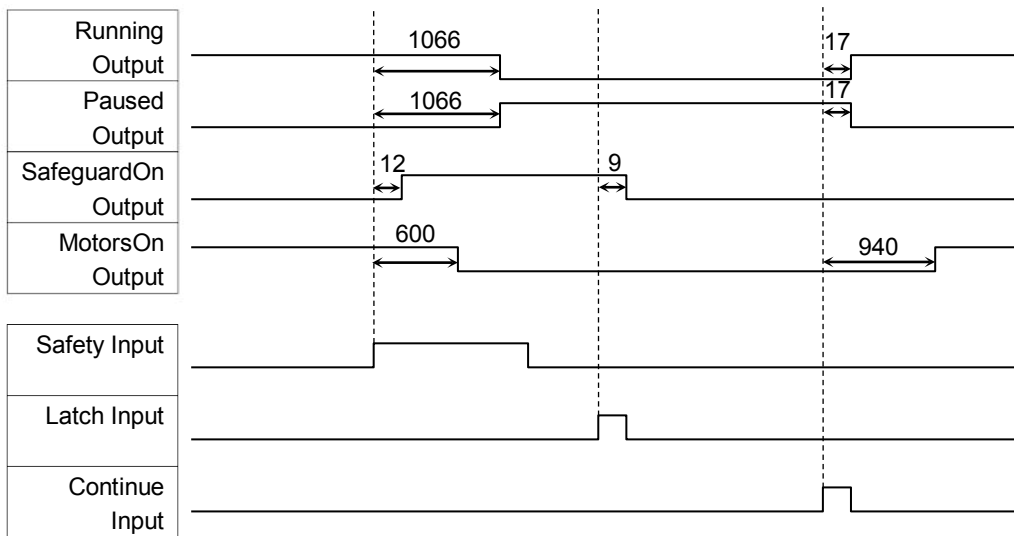

### 14.2.5 Timing Diagram for Emergency Stop Sequence

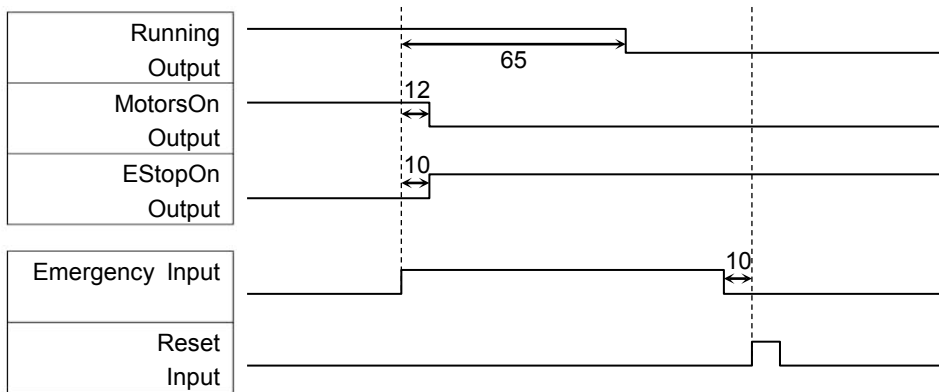



## 15. SD Card Slots



CAUTION

- Do not use any SD card other than accessories.  
If using other SD card, system may not operate properly.
- SD card is only available for robot system.  
SD card is written only for robot system. Unable to use for reading/writing data.  
If you write data on SD card, robot system may not operate properly.

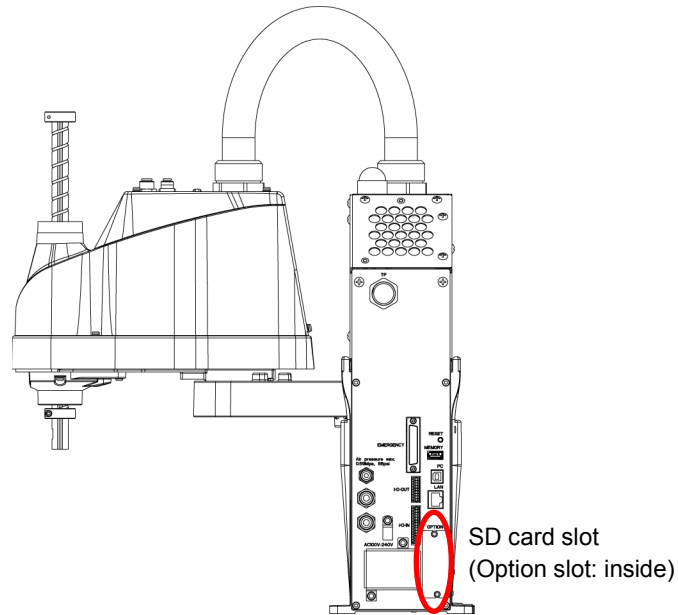

(Illustration: T3-401S)

SD card slot is a slot for inserting SD card.  
Firmware to operate the manipulator is written on SD card.

For replacement method, refer to *Maintenance: 14.3 Replacement of SD card.*

# 16. RESET Switch

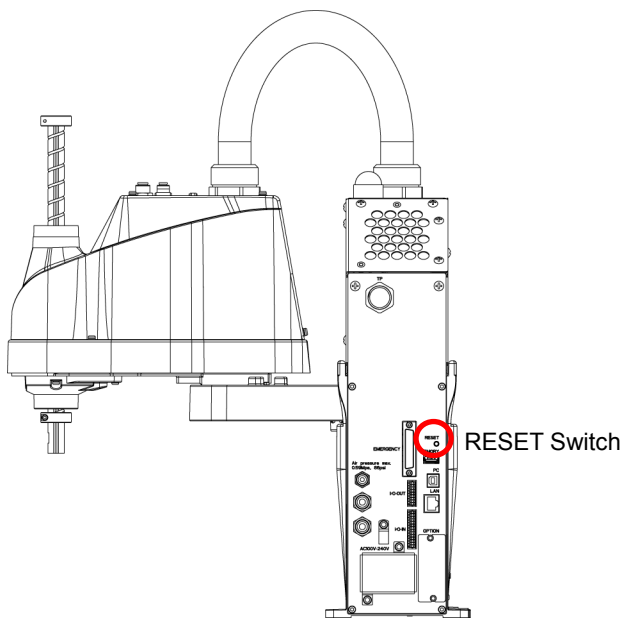

(Illustration: T3-401S)

RESET switch has following function.

### Manipulator reboot

Push the RESET switch for three seconds when booting the manipulator.  
Manipulator reboots.

Shape of RESET switch is difficult to push. Push with sharp edged object as shown in the figure below when pushing the RESET switch.

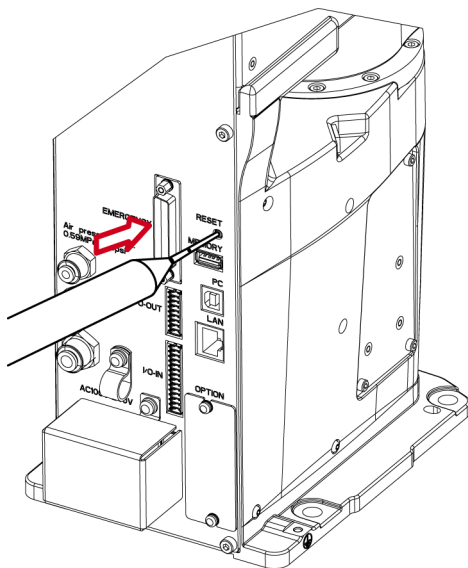

## 17. Fieldbus I/O

Fieldbus I/O of the T series supports the following model.

DeviceNet™	CC-Link
PROFIBUS-DP	PROFINET
EtherNet/IP™	EtherCAT®

For details, refer to the following manual.

*Robot Controller RC700 / RC90 Option Fieldbus I/O*

 <b>WARNING</b>	<ul style="list-style-type: none"> <li>■ Do not connect or disconnect the motor connectors while the power to the robot system is turned ON. Connecting or disconnecting the motor connectors with the power ON is extremely hazardous and may result in serious bodily injury as the Manipulator may move abnormally, and also may result in electric shock and/or malfunction of the robot system.</li> <li>■ To shut off power to the robot system, disconnect the power plug from the power source. Be sure to connect the AC power cable to a power receptacle. DO NOT connect it directly to a factory power source.</li> <li>■ Be sure to perform installing procedure with turning OFF the robot system and related equipment and disconnect the power plug. Performing any replacement procedure with the power ON is extremely hazardous and may result in electric shock and/or malfunction of the robot system.</li> </ul>
---	--

 <b>CAUTION</b>	<ul style="list-style-type: none"> <li>■ Check the tabs of the fieldbus I/O module are securely hooked on the board when installing fieldbus I/O module. If tabs do not be hooked securely, connector or fieldbus I/O module may get damages.</li> </ul>
---	--

Fieldbus I/O  
Module  
Installation

- (1) Turn OFF the Manipulator.
- (2) Remove the option slot cover on the back side of the Manipulator.

Sems bolt: 2-M3×6

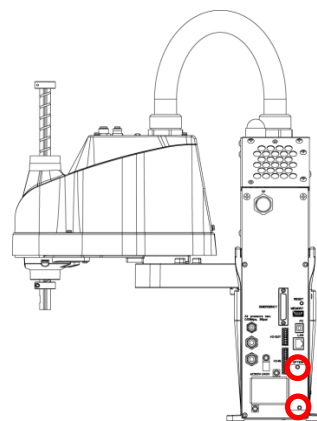

(Illustration: T3-401S)

- (3) Inset the fieldbus I/O module to the option slot.



■ Check the tabs of the fieldbus I/O module are securely hooked on the board when installing fieldbus I/O module. If tabs do not be hooked securely, connector or fieldbus I/O module may get damages.

- (4) Tighten screws by using special tool until fieldbus I/O module is fixed completely.



Image of installation



Front



Back

Fieldbus I/O  
Module  
Removal

- (1) Unscrew the screws by using special tool until fieldbus I/O module is loosened.
- (2) Remove the fieldbus I/O module.  
You can remove the module by pulling loosened screws toward.
- (3) Mount the option slot cover.

# Maintenance

This volume contains maintenance procedures with safety precautions for T series Manipulators.



# 1. Safety Maintenance

Please read this chapter, this manual, and other relevant manuals carefully to understand safe maintenance procedures before performing any routine maintenance.

Only authorized personnel who have taken safety training should be allowed to maintain the robot system.

Safety training is the program for industrial robot operators that follows the laws and regulations of each nation.

The personnel who have taken safety training acquire knowledge of industrial robots (operations, teaching, etc.), knowledge of inspections, and knowledge of related rules/regulations.

The personnel who have completed the robot system-training and maintenance-training classes held by the manufacturer, dealer, or locally-incorporated company are allowed to maintain the robot system.



- Do not remove any parts that are not covered in this manual. Follow the maintenance procedure strictly as described in this manual. Improper removal of parts or improper maintenance may not only cause improper function of the robot system but also serious safety problems.
- Keep away from the Manipulator while the power is ON if you have not taken the training courses. Do not enter the operating area while the power is ON. Entering the operating area with the power ON is extremely hazardous and may cause serious safety problems as the Manipulator may move even it seems to be stopped.
- When you check the operation of the Manipulator after replacing parts, be sure to check it while you are outside of the safeguarded area. Checking the operation of the Manipulator while you are inside of the safeguarded area may cause serious safety problems as the Manipulator may move unexpectedly.
- Before operating the robot system, make sure that both the Emergency Stop switches and safeguard switch function properly. Operating the robot system when the switches do not function properly is extremely hazardous and may result in serious bodily injury and/or serious damage to the robot system as the switches cannot fulfill their intended functions in an emergency.



- To shut off power to the robot system, disconnect the power plug from the power source. Be sure to connect the AC power cable to a power receptacle. DO NOT connect it directly to a factory power source.
- Before performing any replacement procedure, turn OFF the Controller and related equipment, and then disconnect the power plug from the power source. Performing any replacement procedure with the power ON is extremely hazardous and may result in electric shock and/or malfunction of the robot system.

 WARNING	<ul style="list-style-type: none"> <li>Be sure to connect the cables properly. Do not allow unnecessary strain on the cables. (Do not put heavy objects on the cables. Do not bend or pull the cables forcibly.) The unnecessary strain on the cables may result in damage to the cables, disconnection, and/or contact failure. Damaged cables, disconnection, or contact failure is extremely hazardous and may result in electric shock and/or improper function of the robot system.</li> </ul>
--	---

 CAUTION	<ul style="list-style-type: none"> <li>Manipulator may be warmed up due to motor heat or similar causes. Do not touch the Manipulator until temperature falls. Also, make sure the temperature of the Manipulator falls and is not hot when you touch it. Then perform teaching or maintenance.</li> </ul>
--	--

## 2. General Maintenance

This chapter describes maintenance inspections and procedures. Performing maintenance inspections and procedures properly is essential for preventing trouble and ensuring safety. Be sure to perform the maintenance inspections in accordance with the schedule.

### 2.1 Maintenance Inspection

#### 2.1.1 Schedule for Maintenance Inspection

Inspection points are divided into five stages: daily, monthly, quarterly, biannual, and annual. The inspection points are added every stage.

If the Manipulator is operated for 250 hours or longer per month, the inspection points must be added every 250 hours, 750 hours, 1500 hours, and 3000 hours operation.

	Inspection Point					
	Daily inspection	Monthly inspection	Quarterly inspection	Biannual inspection	Annual inspection	Overhaul (replacement)
1 month (250 h)	Inspect every day	√				
2 months (500 h)		√				
3 months (750 h)		√	√			
4 months (1000 h)		√				
5 months (1250 h)		√				
6 months (1500 h)		√	√	√		
7 months (1750 h)		√				
8 months (2000 h)		√				
9 months (2250 h)		√	√			
10 months (2500 h)		√				
11 months (2750 h)		√				
12 months (3000 h)		√	√	√	√	
13 months (3250 h)		√				
⋮	⋮	⋮	⋮	⋮	⋮	
20000 h					√	

h = hour



2.1.2 Inspection Point

Inspection While the Power is OFF (Manipulator is not operating)

Inspection Point	Inspection Place	Daily	Monthly	Quarterly	Biannual	Annual
Check looseness or backlash of bolts, screws. Tighten them if necessary. (For the tightening torque, refer to <i>Maintenance: 2.4 Tightening Hexagon Socket Head Cap Bolts.</i> )	End effector mounting bolts	√	√	√	√	√
	Manipulator mounting bolts	√	√	√	√	√
	Each arm locking bolts	√	√	√	√	√
	Bolts, screws around shaft					√
	Bolts, screws securing motors, reduction gear units, etc.					√
Check looseness of connectors. If the connectors are loosen, push it securely or tighten.	External connectors on Manipulator (on the connector plates etc.)	√	√	√	√	√
	Manipulator cable unit		√	√	√	√
Visually check for external defects. Clean up if necessary.	External appearance of Manipulator	√	√	√	√	√
	External cables		√	√	√	√
Check for bends or improper location. Repair or place it properly if necessary.	Safeguard etc.	√	√	√	√	√
Check tension of timing belts. Tighten it if necessary.	Inside of Arm #2				√	√
Grease conditions	Refer to <i>Maintenance: 2.3 Greasing.</i>					
Lithium Battery	Refer to <i>Maintenance: 14 Lithium Battery, SD Card, Boards, and Filter.</i>					

Inspection While the Power is ON (Manipulator is operating)

Inspection Point	Inspection Place	Daily	Monthly	Quarterly	Biannual	Annual
Check motion range	Each joint					√
Move the cables back and forth lightly to check whether the cables are disconnected.	External cables (including cable unit of the Manipulator)				√	√
Push each arm in MOTOR ON status to check whether backlash exists.	Each arm					√
Check whether unusual sound or vibration occurs.	Whole	√	√	√	√	√
Measure the accuracy repeatedly by a dial gauge when positional gap occurs.	Whole					√
Turn ON and OFF the brake release switch and check the sound of the solenoid brake. If there is no sound, replace the brake.	Brake	√	√	√	√	√

## 2.2 Overhaul (Parts Replacement)



- Overhaul timing is based on an assumption that all joints are operated for equal distance. If a particular joint has a high duty or high load, it is recommended to overhaul all joints (as many as possible) before exceeding 20,000 operation hours with the joint as a basis.

The parts for the manipulator joints may cause accuracy decline or malfunction due to deterioration of the manipulator resulting from long term use. In order to use the manipulator for a long term, it is recommended to overhaul the parts (parts replacement).

The time between overhauls is 20,000 operation hours of the Manipulator as a rough indication.

However, it may vary depending on usage condition and degree of the load (such as when operated with the maximum motion speed and maximum acceleration / deceleration in continuous operation) applied on the Manipulator.



NOTE For the EPSON RC+ 7.0 the recommended replacement time for the parts subject to maintenance (motors, reduction gear units, and timing belts) can be checked in the [Maintenance] dialog box.

Refer to the *Maintenance: 4. Alarm*.

Note:

The recommended replacement time for the maintenance parts is when it reaches the L10 life (time until 10% failure probability). In the [Maintenance] dialog box, the L10 life is displayed as 100%.

The manipulator operation hours can be checked in [Controller Status Viewer] dialog -[Motor On Hours].

- (1) Select EPSON RC+ menu-[Tools]-[Controller] to open the [Controller Tools] dialog.
- (2) Click the <View Controller Status> button to open the [Browse For Folder] dialog.
- (3) Select the folder where the information is stored.
- (4) Click <OK> to view the [Controller Status Viewer] dialog.
- (5) Select [Robot] from the tree menu on the left side.

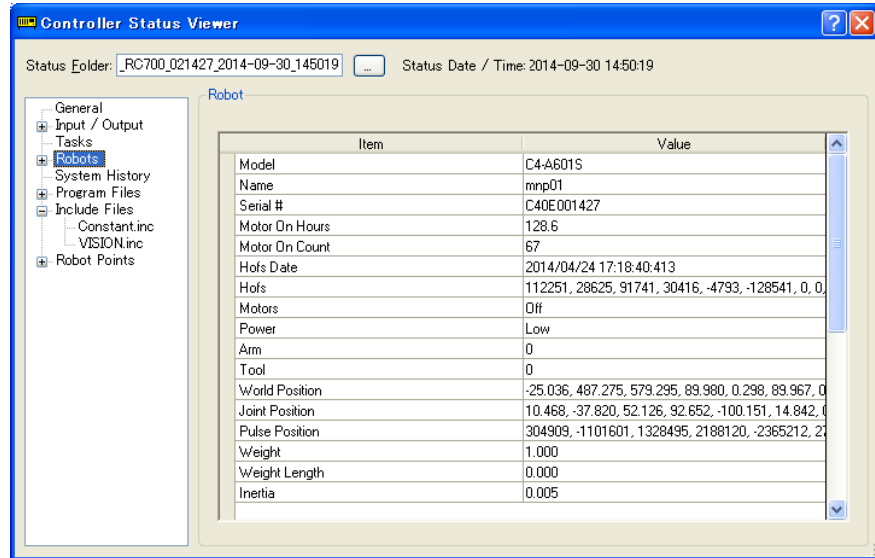

For the parts subject to overhaul, refer to *Maintenance: 19. Maintenance Parts List*.

For details of replacement of each part, refer to the *Maintenance* section.

Please contact the distributor of your region for further information.

## 2.3 Greasing

The ball screw spline and reduction gear units need greasing regularly. Only use the grease specified in the following table.

 CAUTION	<ul style="list-style-type: none"> <li>■ Keep enough grease in the Manipulator. Operating the Manipulator with insufficient grease will damage sliding parts and/or result in insufficient function of the Manipulator. Once the parts are damaged, a lot of time and money will be required for the repairs.</li> </ul>
--	--

 CAUTION	<ul style="list-style-type: none"> <li>■ If grease gets into your eyes, mouth, or on your skin, follow the instructions below.                     <ul style="list-style-type: none"> <li>If grease gets into your eyes                             <ul style="list-style-type: none"> <li>: Flush them thoroughly with clean water, and then see a doctor immediately.</li> </ul> </li> <li>If grease gets into your mouth                             <ul style="list-style-type: none"> <li>: If swallowed, do not induce vomiting. See a doctor immediately.</li> <li>: If grease just gets into your mouth, wash out your mouth with water thoroughly.</li> </ul> </li> <li>If grease gets on your skin                             <ul style="list-style-type: none"> <li>: Wash the area thoroughly with soap and water.</li> </ul> </li> </ul> </li> </ul>
--	--

	Greasing part	Greasing Interval	Grease	Refer to <i>Maintenance</i> :
Joint #1	Reduction gear units	Overhaul timing	T3:SK-2 T6: SK-1A	9. Joint #1
Joint #2				10. Joint #2
Joint #3	Ball screw spline unit	At 100 km of operation (50 km for first greasing)	AFB	13. Greasing the Ball Screw Spline Unit

### Joint #1, 2 reduction gear units

As a rough indication, perform greasing at the same timing as overhaul.

However, it may vary depending on usage condition and degree of the load (such as when operated with the maximum motion speed and maximum acceleration / deceleration in continuous operation) applied on the Manipulator.

### Joint #3 Ball screw spline unit

The recommended greasing interval is at 100 km of operation. However, greasing timing also can be checked from the grease condition. Perform greasing if the grease is discolored or becomes dry.



Normal grease



Discolored grease

Perform greasing at 50 km of operation for the first time of greasing.

**NOTE**  For the EPSON RC+ 7.0 the recommended replacement time for the grease on the ball screw spline unit can be checked in the [Maintenance] dialog box. For details, refer to the following manual.

Refer to the *Maintenance 4. Alarm*

## 2.4 Tightening Hexagon Socket Head Cap Bolts

Hexagon socket head cap bolts (herein after referred to as bolt) are used in places where mechanical strength is required. These bolts are fastened with the tightening torques shown in the following table.

When it is necessary to refasten these bolts in some procedures in this manual (except special cases as noted), use a torque wrench so that the bolts are fastened with the appropriate tightening torques as shown below.

Bolt	Tightening Torque
M3	2.0 ± 0.1 N·m (21 ± 1 kgf·cm)
M4	4.0 ± 0.2 N·m (41 ± 2 kgf·cm)
M5	8.0 ± 0.4 N·m (82 ± 4 kgf·cm)
M6	13.0 ± 0.6 N·m (133 ± 6 kgf·cm)
M8	32.0 ± 1.6 N·m (326 ± 16 kgf·cm)
M10	58.0 ± 2.9 N·m (590 ± 30 kgf·cm)
M12	100.0 ± 5.0 N·m (1,020 ± 51 kgf·cm)

Refer below for the set screw.

Set Screw	Tightening Torque
M4	2.4 ± 0.1 N·m (26 ± 1 kgf·cm)
M5	4.0 ± 0.2 N·m (41 ± 2 kgf·cm)

The bolts aligned on a circumference should be fastened in a crisscross pattern as shown in the figure below.

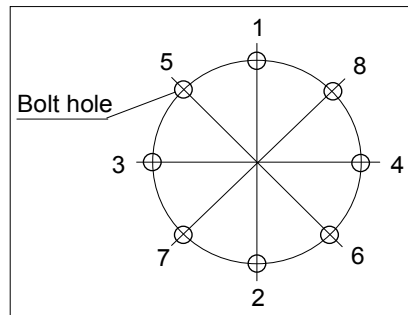

Do not fasten all bolts securely at one time. Divide the number of times that the bolts are fastened into two or three and fasten the bolts securely with a hexagonal wrench. Then, use a torque wrench so that the bolts are fastened with tightening torques shown in the table above.

## 2.5 Matching Origins

After parts have been replaced (motors, reduction gear units, a brake, timing belts, a ball screw spline unit, etc.), the Manipulator cannot operate properly because a mismatch exists between the origin stored in each motor and its corresponding origin stored in the Robot system.

Because of that, it is necessary to perform calibration (encoder rest and calibration) to match these origins.

For calibration, the pulse values for a specific position must be recorded in advance.

Before replacing parts, select easy point (pose) data from the registered point data to check the accuracy. Then, follow the steps below to display the pulse values and record them.

EPSON  
RC+

Execute the following command from the [Command Window].

```
>PULSE
```

```
PULSE: [Joint #1 Pulse value] pls [Joint #2 Pulse value] pls [Joint #3 Pulse value]
pls [Joint #4 Pulse value] pls
```

## 2.6 Layout of Maintenance Parts

T3

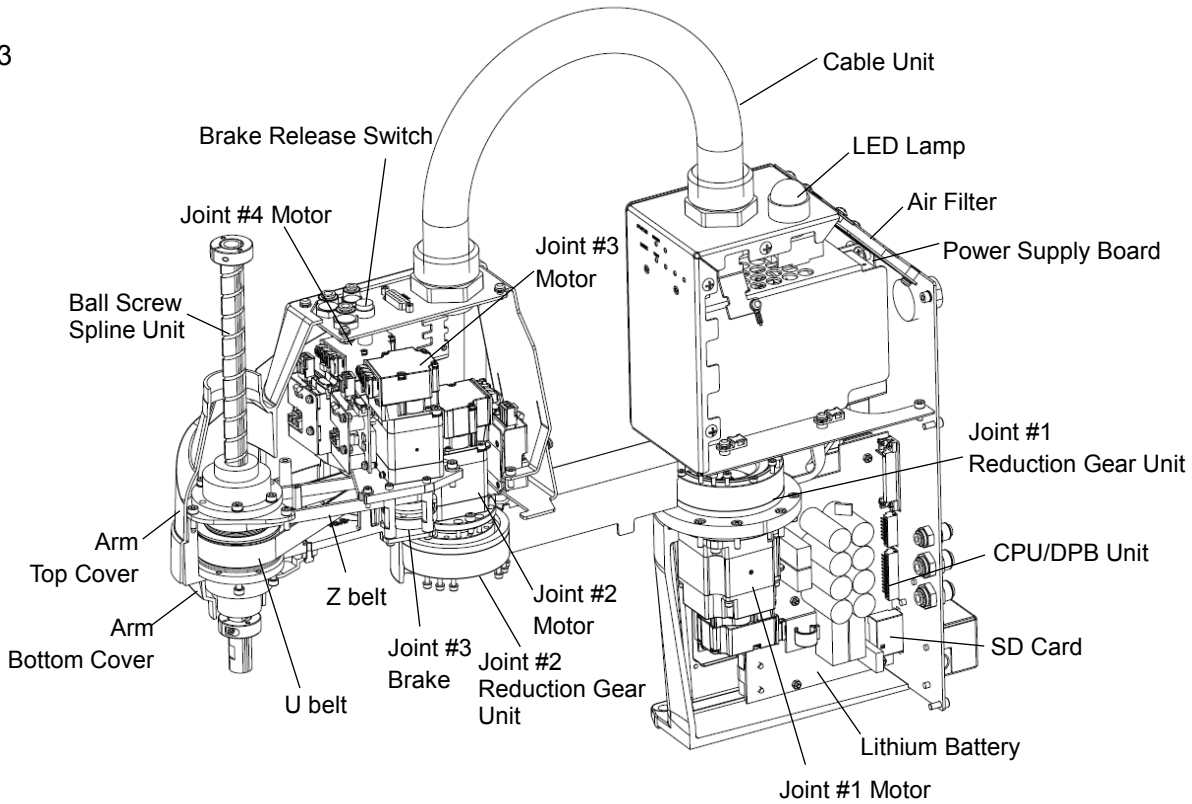

T6

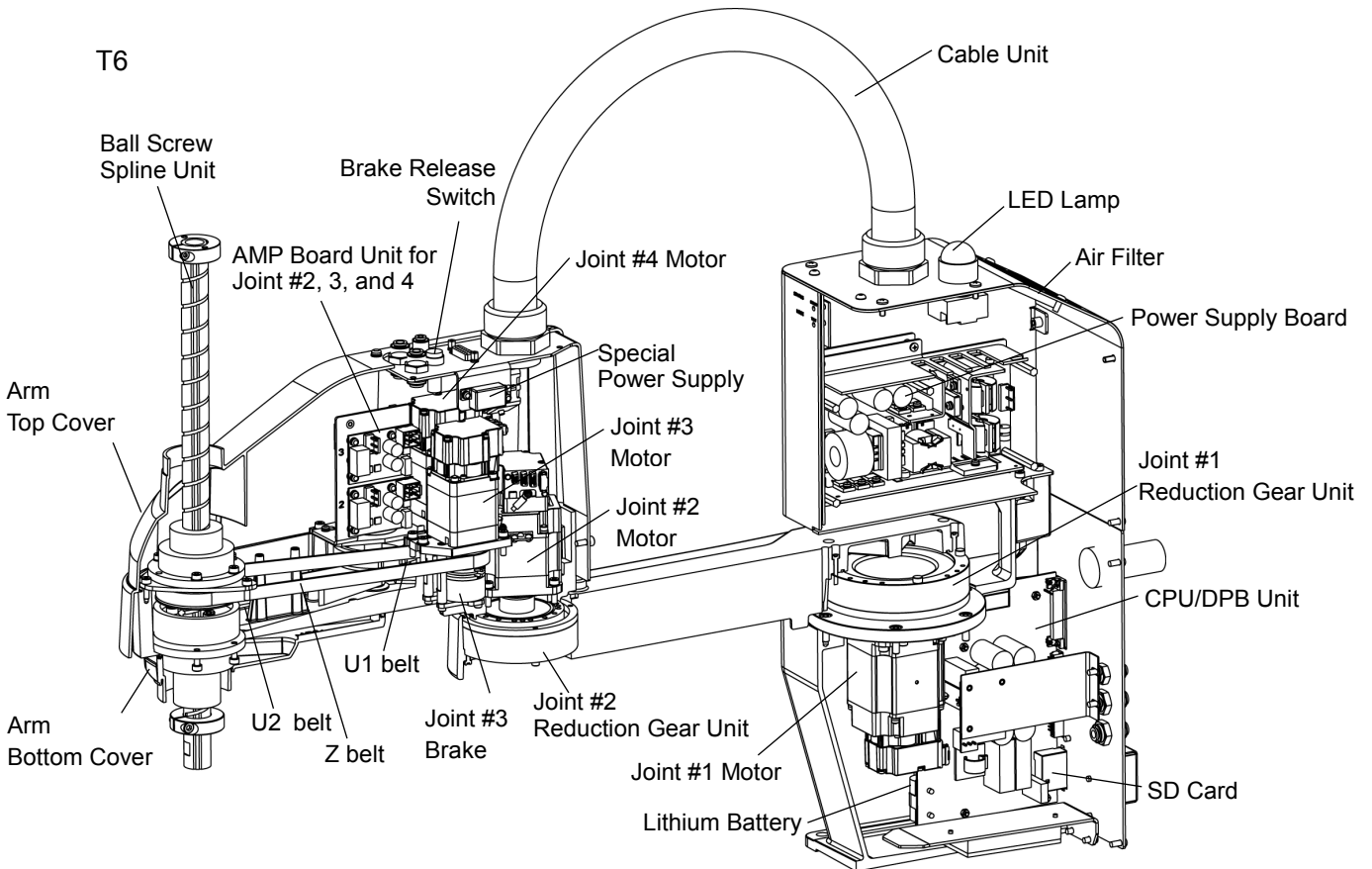

# 3. Manipulator Structure

T3

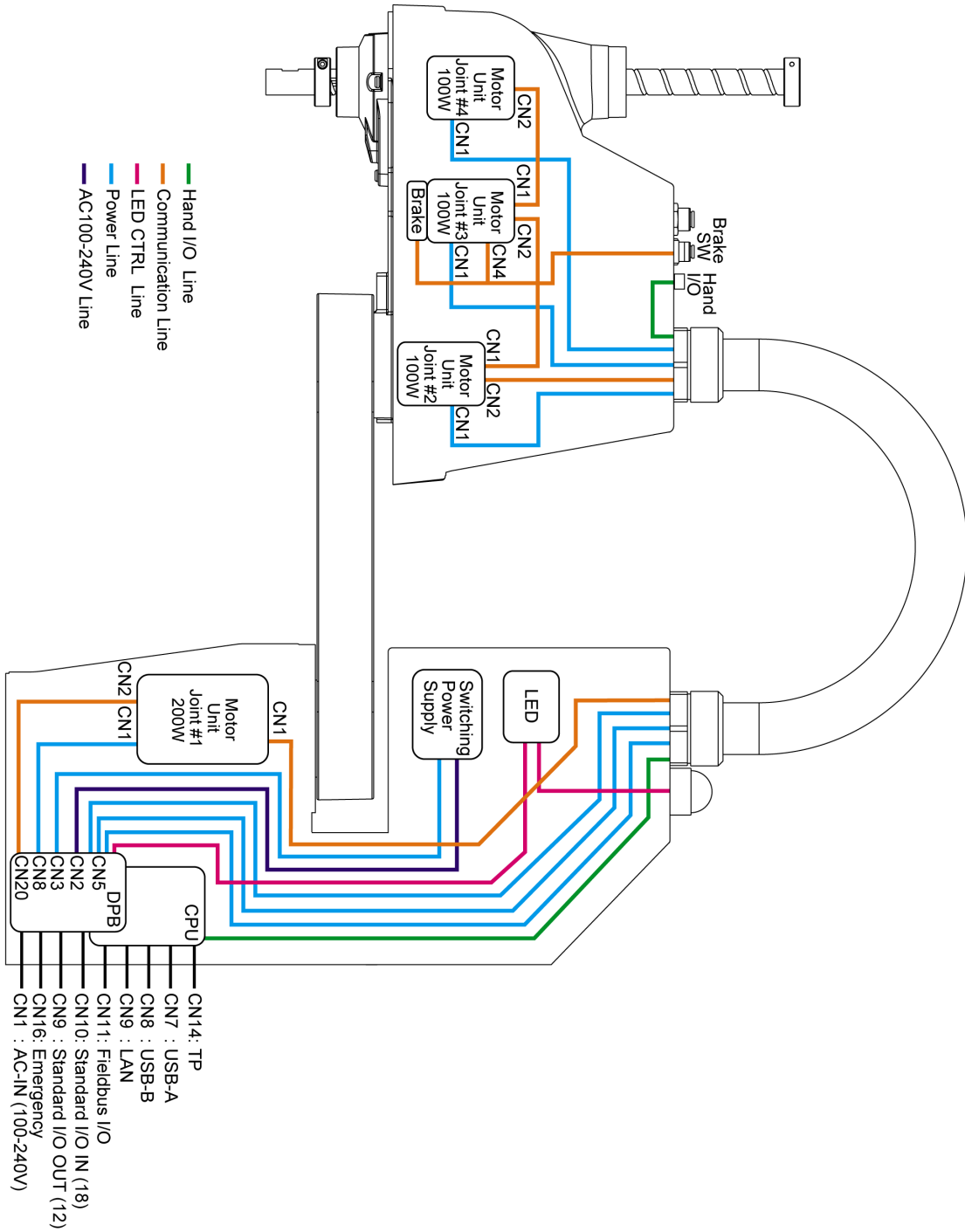

T6

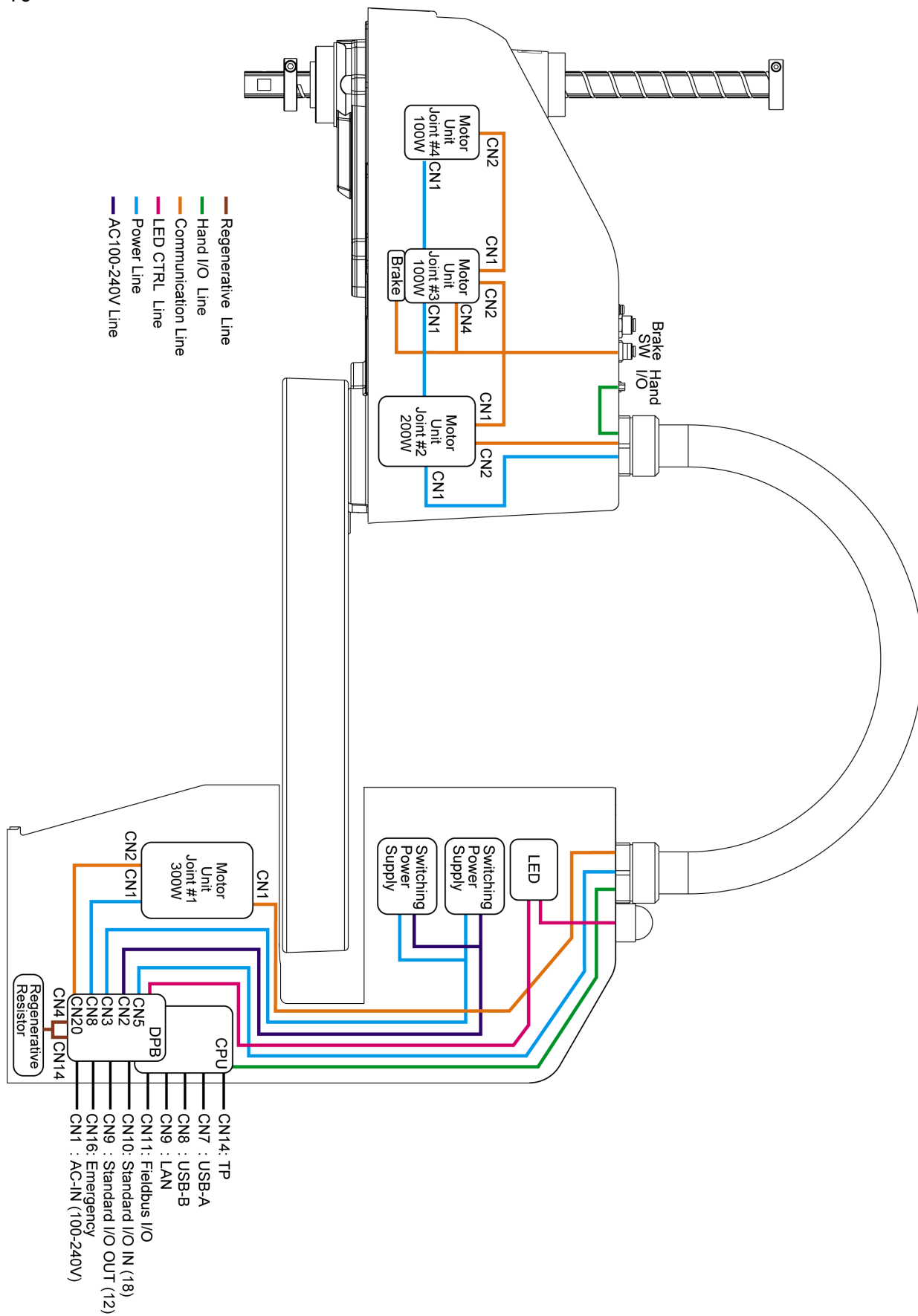



## 4. Alarm

When the lithium batteries run out, a voltage reduction alarm warning occurs. However, the warning does not guarantee that the battery lasts until you replace it. Therefore, you need to replace the battery immediately. If the battery has run out, the manipulator parameters will be lost and recalibration of the manipulator will be required.

In addition, the parts of the manipulator joints may cause accuracy decline or malfunction due to deterioration of the parts resulting from long term use. If the manipulator breaks down due to deterioration of the parts, it will take significant time and cost for repair.

The following sections describe the alarm function which announces the following maintenance timings in order to perform maintenance well ahead of time before the warning error.

- Battery replacement
- Grease up
- Replacement of the timing belt
- Replacement of the motor
- Replacement of the reduction gear unit
- Replacement of the ball screw spline unit

## 4.1 Maintenance

The recommended replacement time can be configured for the batteries, grease, timing belts, motors, reduction gear units, and ball screw spline units.

 CAUTION	<ul style="list-style-type: none"> <li>■ Make sure that the date and time on the Manipulator are set correctly. Maintenance cannot be performed properly with improper date and time setting.</li> <li>■ If the CPU/DPB board or SD card is replaced, the Maintenance information may be lost. When you replaced these parts, confirm the date and time of the Manipulator and the Maintenance information.</li> </ul>
--	--



NOTE Settings of the Maintenance are different depending on installation methods of the firmware.

Initial installation : Maintenance is enabled.

Upgrade : Maintenance inherits the previous data.  
(Disables as default)

For details for enabling or disabling the Maintenance, refer to the *EPSON RC+ 7.0 User's Guide 5.12.2 [System Configuration] Command (Setup Menu) - [Setup]-[System Configuration]-[Controller]-[Preferences] Page.*



NOTE Maintenance is enabled at shipment.

### 4.1.1 Manipulator Maintenance Information

If enabled, the Maintenance information for the battery, timing belts, motors, reduction gear units, ball screw spline unit, and grease up will be configured automatically when the robot is configured or changed.

The following parts are subject to grease up:

Ball screw spline unit on the Joint # 3

When the manipulator is deleted from the configuration, the Maintenance information will also be automatically deleted.

For details on the manipulator configuration, refer to *the EPSON RC+ 7.0 User's Guide 10.1 Setting the Robot Model.*

 CAUTION	<ul style="list-style-type: none"> <li>■ Changing of the manipulator should be done carefully. The alarm setting will be reset when the manipulator is changed.</li> </ul>
--	--

### 4.1.2 Manipulator Maintenance Information

If the Maintenance is enabled, the battery is automatically configured at the first connection.

## 4.2 Maintenance Information

### 4.2.1 How to View the Maintenance Information

The configured Maintenance information can be checked in the EPSON RC+.

- (1) Select the EPSON RC+ 7.0 menu-[Tools]-[Maintenance] to display the [Controller Tools] dialog box.

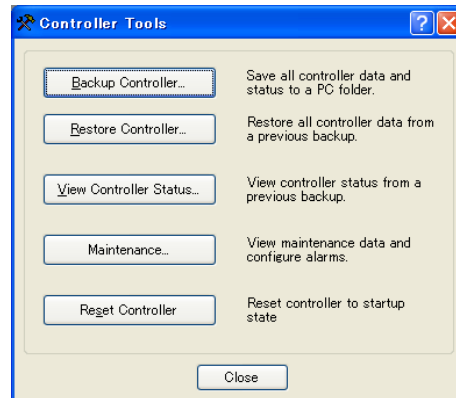

- (2) To check the controller Maintenance information, click the <Maintenance> button and display the [Maintenance] dialog box.

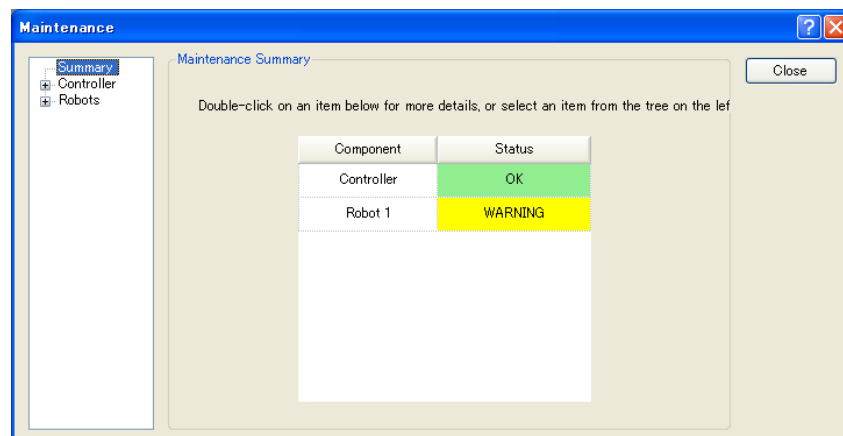

- (3) Select “General” or specify the axis from the tree to display information of the target parts.

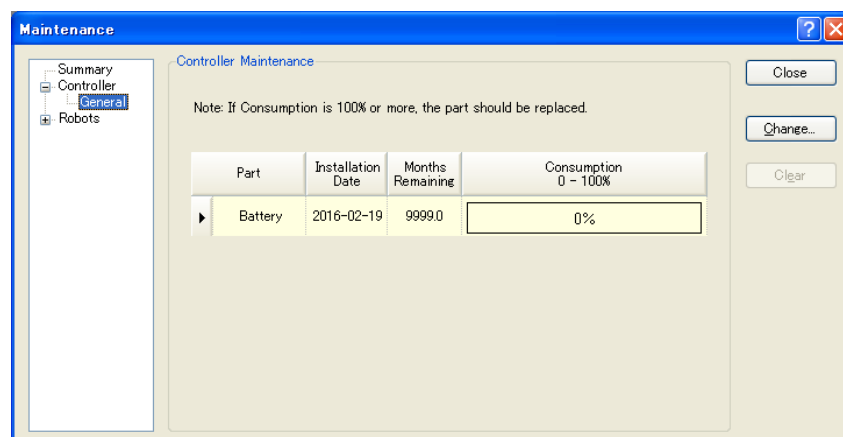

The recommended replacement time for the battery is calculated based on the battery capacity and the Manipulator ON time. The battery may run out if it passes the recommended replacement time.

**NOTE**  The recommended replacement time for the grease is calculated based on the elapsed days since date of grease up. The replacement time may be shorter or longer depending on usage condition, such the load applied on the robot.

**NOTE**  The recommended replacement time for the parts (timing belts, motors, reduction gear units, and ball screw spline unit) is when it reaches the L10 life (time until 10% failure probability). In the dialog window, the L10 life is displayed as 100%.

### 4.2.2 How to Edit the Maintenance Information

The configured Maintenance information can be edited in the EPSON RC+.

- (1) Select the EPSON RC+ 7.0 menu-[Tools]-[Maintenance] to display the [Controller Tools] dialog box.
- (2) To edit the Maintenance information, display the [Maintenance] dialog box.
- (3) Select “General” or specify the axis from the tree to display information of the target parts.
- (4) Select the alarm to be changed and click the <Change> button.
- (5) Display the [Change Alarm] dialog box and enter any of the following.



- Purchase or replacement date of the battery
- Date of grease up
- Purchase or replacement date of the timing belt
- Purchase or replacement date of the motor
- Purchase or replacement date of the reduction gear unit
- Purchase or replacement date of the ball screw spline unit

- (6) Click the <OK> button and change the specified alarm information.

**NOTE**  The offset can be set for the consumption rate of already installed parts. Follow the steps below to calculate a rough offset setting value.

1. Measure the usable months for the past operation by HealthRBAAnalysis.
2. Confirm the past Motor ON time in the controller status viewer.
3. Calculate a rough offset value with the following formula.

$$\text{Offset} = 100 \times \frac{\text{Motor On time}}{24 \times 30.4375 \times \text{Usable months}}$$

For details, refer to the *EPSON RC+ 7.0 SPEL+ Language Reference*.

### 4.2.3 Alarm Notifying Method

The Manipulator status becomes warning and displays warning message if any parts required to perform replacement or grease up.

For details, refer to the following manual.

*SPEL+ Language Reference SPEL+ Error Message*

The alarm notifying method can be configured by the output bit of the Remote I/O.

The Remote I/O can be configured in the EPSON RC+ 7.0- [Setup] - [System Configuration] - [Controller] - [Remote Control].

For details, refer to *EPSON RC+ 7.0 User's Guide 12.1 Remote I/O*.

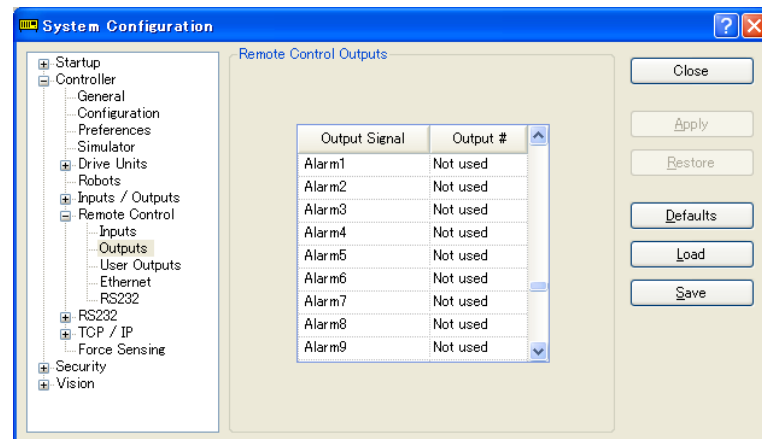

NOTE  

The controller enters the warning state if an alarm occurs.

### 4.2.4 How to Cancel the Alarm

An alarm occurs when the consumption rate of the parts reaches 100%.

NOTE  

The alarm cannot be canceled by executing the Reset command or restarting the controller. The alarm can be canceled by the following method.

Operation from [Maintenance] dialog box of the EPSON RC+ 7.0

HealthCtrlReset Command

HealthRBReset Command

Refer to *Maintenance 4.2.2 How to Edit the Maintenance Information* to change the alarm information in the same steps.

## 5. Backup and Restore

### 5.1 What is the Backup Controller Function

The Manipulator configuration set by EPSON RC+ 7.0 can be stored with the “Backup Controller” function.

The Manipulator settings can be restored easily using the data previously stored with “Backup Controller” after a configuration mistake or Manipulator problem.

Be sure to execute “Backup Controller” before changing the Manipulator setup, before maintenance, or after teaching.

For some problems, backup may not be available before maintenance has to be performed. Be sure to backup the data after making changes, before problems occur.

**NOTE**  “Controller Status Storage” is one of the T series functions. It saves the Controller setup data same as “Backup Controller.”

There data can be used as the backup data at restoring.

The methods for “Controller Status Storage” are as follows:

A: “Controller status storage to USB memory”

For details, refer to *Setup & Operation 8. Memory Port*.

B: “Export Controller Status function” in EPSON RC+ 7.0.

For details, refer to *EPSON RC+ 7.0 User's Guide 5.9.9 Import Command (Project Menu)*.

### 5.2 Backup Data Types

The table below shows the files created with “Backup Controller”.

File Name	Overview	
Backup.txt	Information file for restore	File including information for restoring the Manipulator.
CurrentMnp01.PRM	Manipulator parameters	Stores information such as ToolSet.
InitFileSrc.txt	Initial configuration	Stores various Manipulator parameters.
MCSys01.MCD	Manipulator configuration	Stores connected Manipulator information.
All the files related to Project	Project related	All the project files transferred to the Controller. Includes program files when EPSON RC+ 7.0 is configured to transfer source code to the Controller.
GlobalPreserves.dat	Global Preserve variables	Saves values of Global Preserve variables.
WorkQueues.dat	WorkQue information	Saves information of Queues information of the WorkQue.

## 5.3 Backup

Backup the Manipulator status from the EPSON RC+ 7.0.

- (1) Select EPSON RC+ 7.0 menu-[Tools]-[Controller] to display the [Controller Tools] dialog.

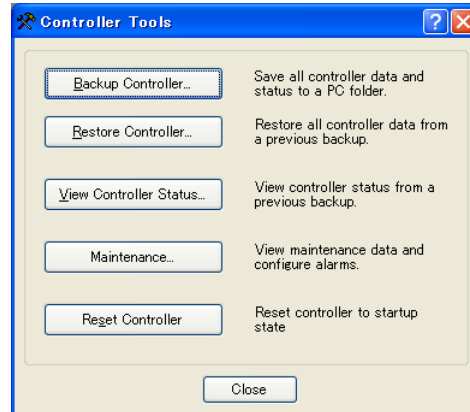

- (2) Click the <Backup Controller...> button to display the [Browse For Folder] dialog.



- (3) Specify the folder to save the backup data. Create a new folder if desired.
- (4) Click the <OK> button. A folder is created in the specified folder containing the backup data with a name in the following format.
- B\_T\_serial number\_date status was saved  
 → Example: B\_T\_12345\_2016-04-03\_092941



CAUTION

- Do not edit the backup files. Otherwise, operation of the robot system after data restoration to the Manipulator is not assured.

## 5.4 Restore

Restore the Manipulator status from the EPSON RC+ 7.0.

 <b>CAUTION</b>	<ul style="list-style-type: none"> <li>■ Make sure that the data used for restore was saved previously for same Manipulator.</li> <li>■ Do not edit the backup files. Otherwise, operation of the robot system after data restoration to the Manipulator is not assured.</li> </ul>
---	---

- (1) Select the EPSON RC+ 7.0 menu-[Tools]-[Controller] to display the [Controller Tools] dialog.

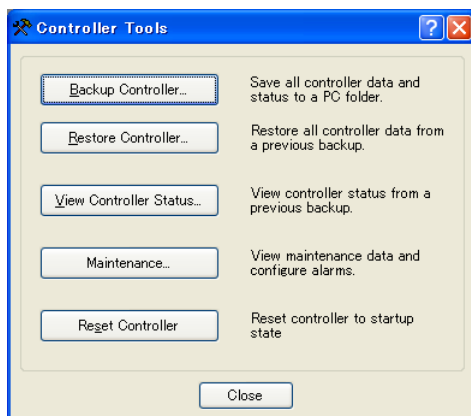

- (2) Click the <Restore Controller...> button to display the [Browse For Folder] dialog.



- (3) Specify the folder that contains the backup data. Backup data folders are named using the following format:

B\_T\_serial number\_date status was saved

→ Example: B\_T\_12345\_2016-04-03\_092941



Controller status backup to USB memory function can also be specified for restore. Specify the following folder.



- (4) Click the <OK> button to display the dialog to select the restore data.

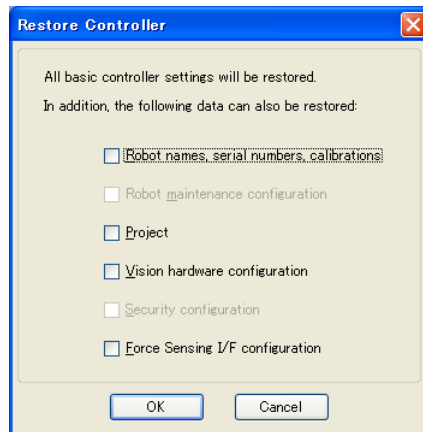

#### Robot name, serial #, calibration

This checkbox allows you to restore the robot (Manipulator) name, Manipulator serial number, Hofs data, and CalPIs data. Make sure that the correct Hofs data is restored. If the wrong Hofs data is restored, the Manipulator may move to wrong positions.

The default setting is unchecked.

#### Robot maintenance configuration

This checkbox allows you to restore the robot alarm related files.

For details, refer to *Maintenance 4. Alarm*.

This is not checked by the default setting.

#### Project

This checkbox allows you to restore the files related to projects.

The default is unchecked.

When a project is restored, the values of Global Preserve variables are loaded.

For details about Global Preserve variable backup, refer to *EPSON RC+ 7.0 User's Guide 5.10.10 Display Variables Command (Run Menu)*.

#### Vision hardware configuration

This checkbox allows you to restore the vision hardware configuration.

For details, refer to *EPSON RC+ 7.0 option Vision Guide 7.0*.

This is not checked by the default setting.

#### Security configuration

This checkbox allows you to restore the security configuration.

For details, refer to *EPSON RC+ 7.0 User's Guide 15. Security*.

This is not checked by the default setting.

- (5) Click the <OK> button to restore the system information.



Restore the system configuration saved using Backup Controller only for the same system. When different system information is restored, the following warning message appears.



Click the <No> button (do not restore data) except for special situations such a manipulator replacement.



When restoring the backup including the robot information other than T series, an error occurs.



You cannot restore the backup including T series robot created in the virtual controller of EPSON RC+ 7.0 to the T series robot.

## 6. Firmware Update

This chapter describes the firmware upgrade procedure and data file initialization when firmware or manipulator configuration errors cause Manipulator startup or operation failure.

### 6.1 Updating Firmware

Firmware (software stored in non-volatile memory) and data files necessary to control the Manipulator are preinstalled in the Manipulator. Controller configuration set from EPSON RC+ 7.0 is always saved in the Manipulator.

Firmware is supplied by CD-ROM as needed. Please contact us for information.

You must use a PC running EPSON RC+ 7.0 connected to a Manipulator with USB to update the Manipulator firmware. Firmware cannot be updated with an Ethernet connection.

### 6.2 Firmware Upgrade Procedure

The firmware upgrade procedure is described as follows:

 <b>CAUTION</b>	<ul style="list-style-type: none"> <li>■ DO NOT unplug the USB cable, or turn OFF the Manipulator or the development PC during upgrade of the firmware. Doing so may result in malfunction of the robot system.</li> </ul>
--	--

- (1) Connect the development PC and the Manipulator with a USB cable (the firmware cannot be changed with an Ethernet connection).
- (2) Turn ON the Manipulator. (Do not start the development software EPSON RC+ 7.0 until the firmware upgrade is completed.)
- (3) Insert the “firmware CD-ROM” in the development PC CD-ROM drive
- (4) Execute “CtrlsetupT.exe”. The following dialog appears.
- (5) Select the <Upgrade> option button and click the <Next> button.

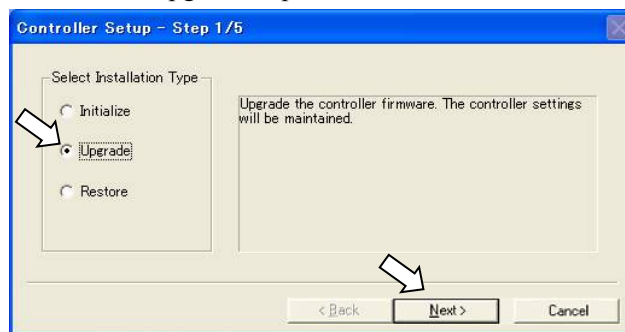

- (6) Make sure that the development PC is connected to the Manipulator with a USB cable and Click the <Next> button.

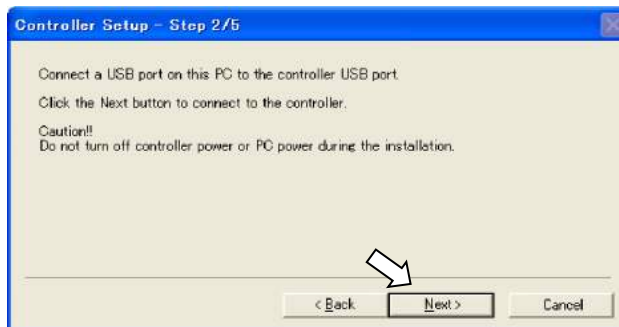

- (7) Check the current firmware version and the new firmware version and click the <Install> button.

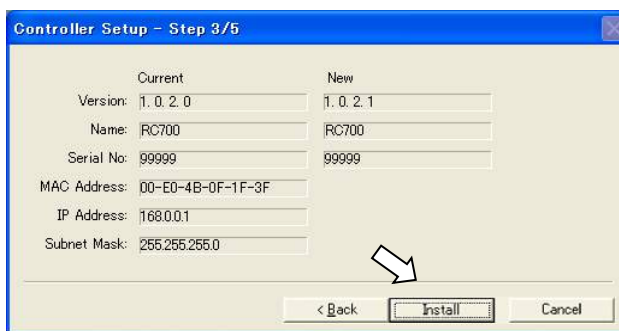

- (8) The firmware upgrade starts. It takes several minutes to complete.

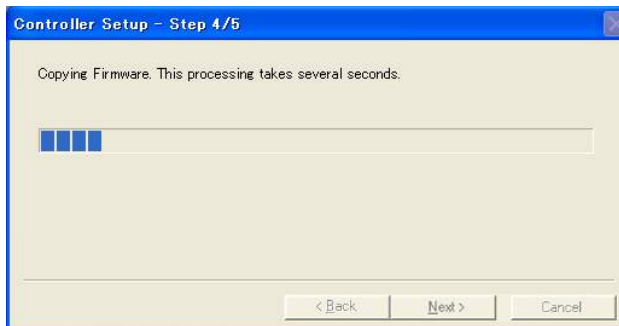

- (9) Continuous data file transfer starts.

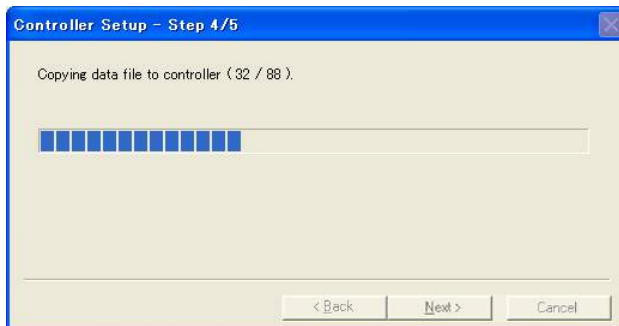

- (10) The following dialog appears when transfer has completed. Click the <Next> button to reboot the Manipulator.

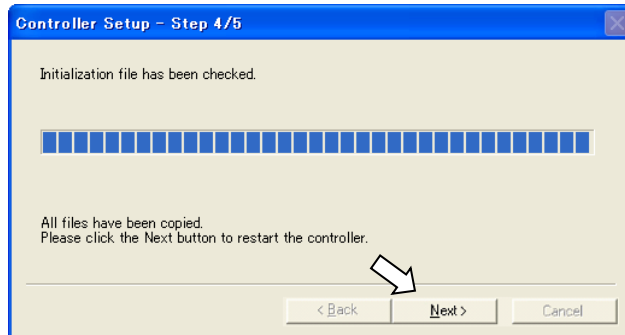

- (11) The following dialog appears after the Controller reboot. Click the <Finish> button.

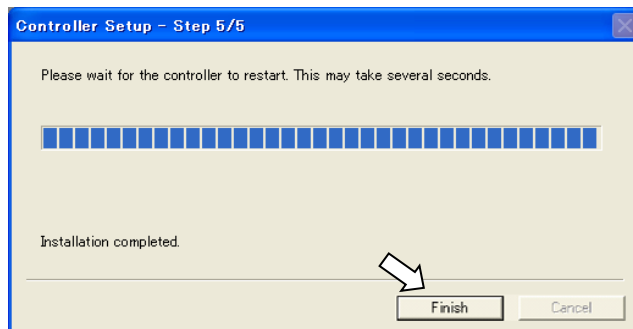

The firmware upgrade is complete.

NOTE  

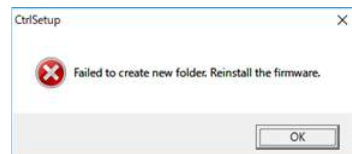

When you install the firmware (Ver.7.4.0.2 or later) on the controller which the firmware (before Ver.7.4.0.2) has been installed, the following message is displayed.



When the message is displayed, re-install the firmware.

## 6.3 Manipulator Recovery

If the Manipulator becomes inoperable, use the procedures described in this section to recover.

**NOTE**  Controller Backup is recommended for easy recovery of the Controller operation. For details of Controller Backup, refer to *Maintenance 5. Backup and Restore*.

## 6.4 Firmware Initialization Procedure

The firmware initialization procedures are described in this section.

 <b>CAUTION</b>	<ul style="list-style-type: none"> <li>■ DO NOT unplug the USB cable, or turn OFF the Manipulator or the development PC during upgrade of the firmware. Doing so may result in malfunction of the robot system.</li> </ul>
---	--

- (1) Connect the development PC to the Manipulator with a USB cable (the firmware cannot be changed with an Ethernet connection).
- (2) Turn ON the Manipulator. Do not start the development software EPSON RC+ 7.0 until firmware initialization is complete.
- (3) Insert the “Firmware CD-ROM” in the development PC CD-ROM drive.
- (4) Execute “Ctrlsetup.exe”.
- (5) Select the <Initialize> option button and click the <Next> button.

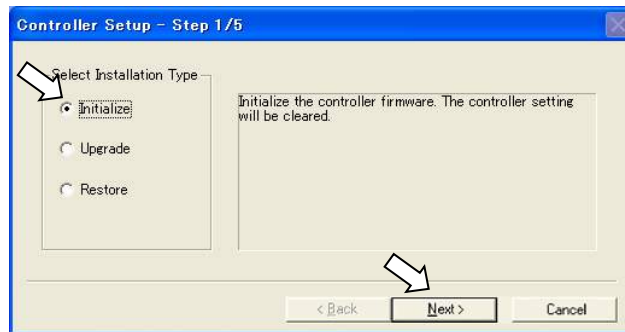

- (6) Make sure that the development PC is connected to the Controller with a USB cable and Click the <Next> button.

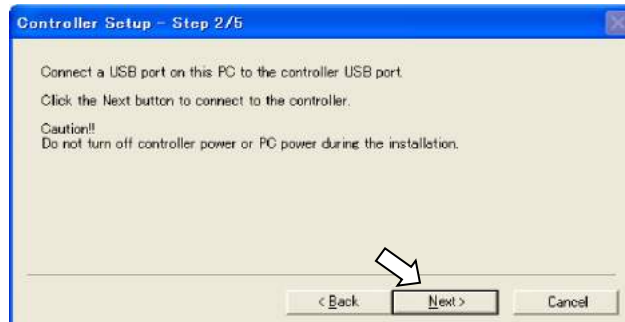

- (7) Check the version information and click the <Install> button.

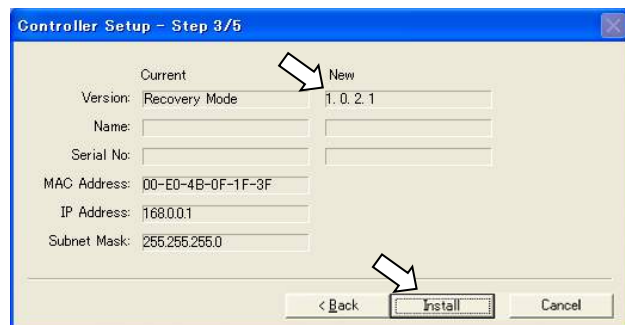

- (8) Firmware and data file transfer starts. It takes several minutes to complete.

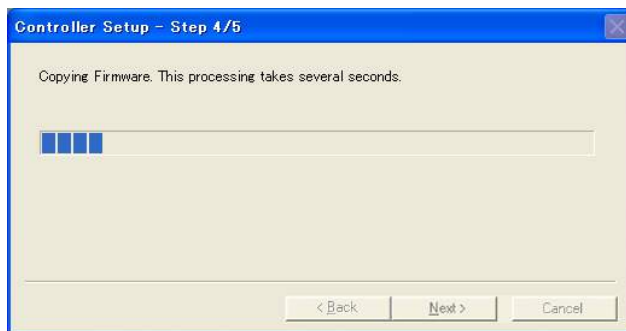

- (9) The following dialog appears when transfer is completed. Click the <Next> button to reboot the Manipulator.

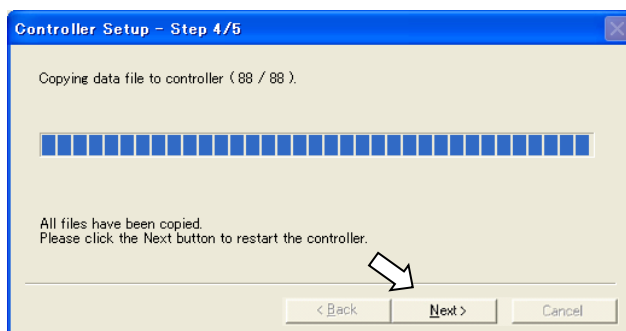

- (10) The following dialog appears after the Manipulator reboot. Click the <Finish> button.

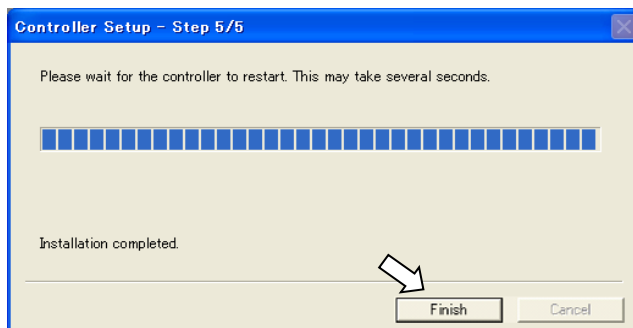

The firmware upgrade is completed.

Start EPSON RC+ 7.0 and restore the Controller settings.

For details of restoring the operating system, refer to *Maintenance 5. Backup and Restore*.

NOTE  

When you install the firmware (Ver.7.4.0.2 or later) on the controller which the firmware (before Ver.7.4.0.2) has been installed, the following message is displayed.

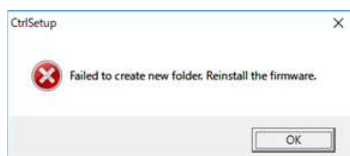

When the message is displayed, re-install the firmware.



## 7. Covers

All procedures for removing and installing covers in maintenance are described in this chapter.



WARNING

- Do not connect or disconnect the motor connectors while the power to the robot system is turned ON. Connecting or disconnecting the motor connectors with the power ON is extremely hazardous and may result in serious bodily injury as the Manipulator may move abnormally, and also may result in electric shock and/or malfunction of the robot system.
- To shut off power to the robot system, disconnect the power plug from the power source. Be sure to connect the AC power cable to a power receptacle. DO NOT connect it directly to a factory power source.
- Before performing any replacement procedure, turn OFF the Controller and related equipment, and then disconnect the power plug from the power source. Performing any replacement procedure with the power ON is extremely hazardous and may result in electric shock and/or malfunction of the robot system.
- Be careful not to get any foreign substances in the Manipulator, connectors, and pins during maintenance. Turning ON the power to the robot system when any foreign substances exist in them is extremely hazardous and may result in electric shock and/or malfunction of the robot system.

T3

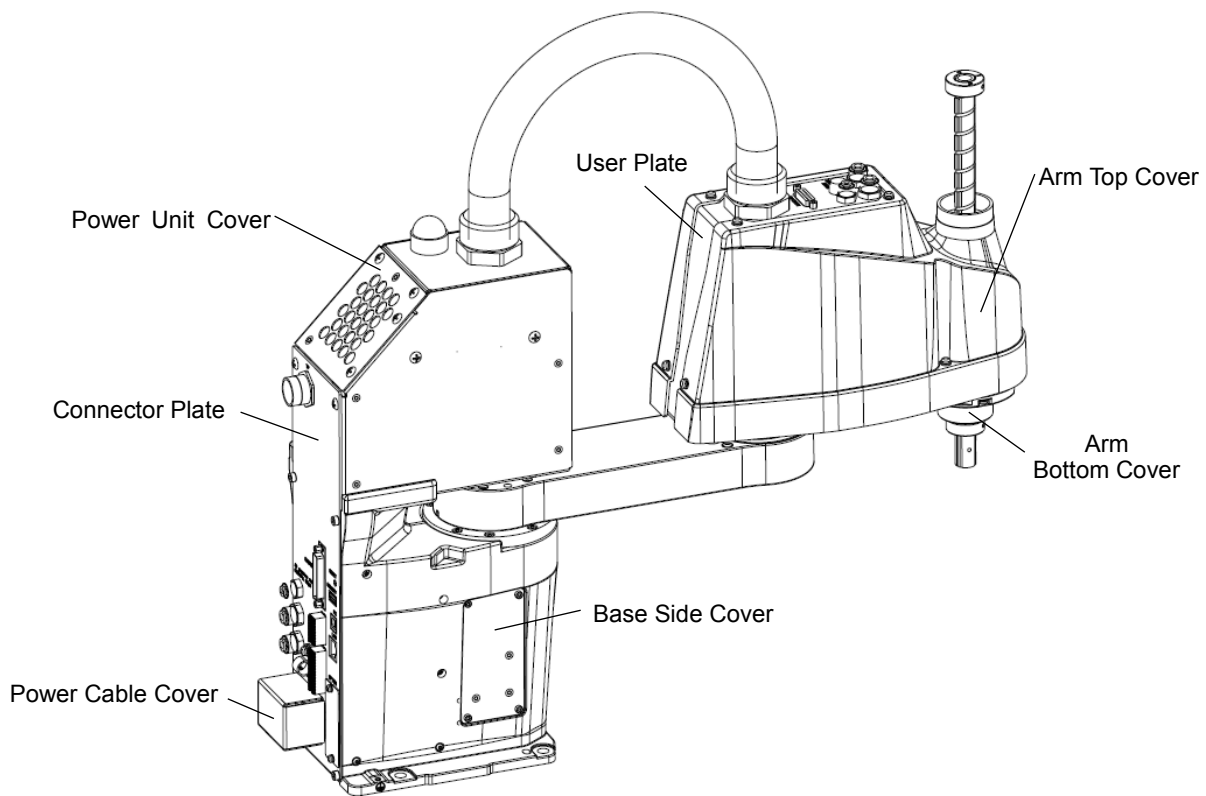

T6

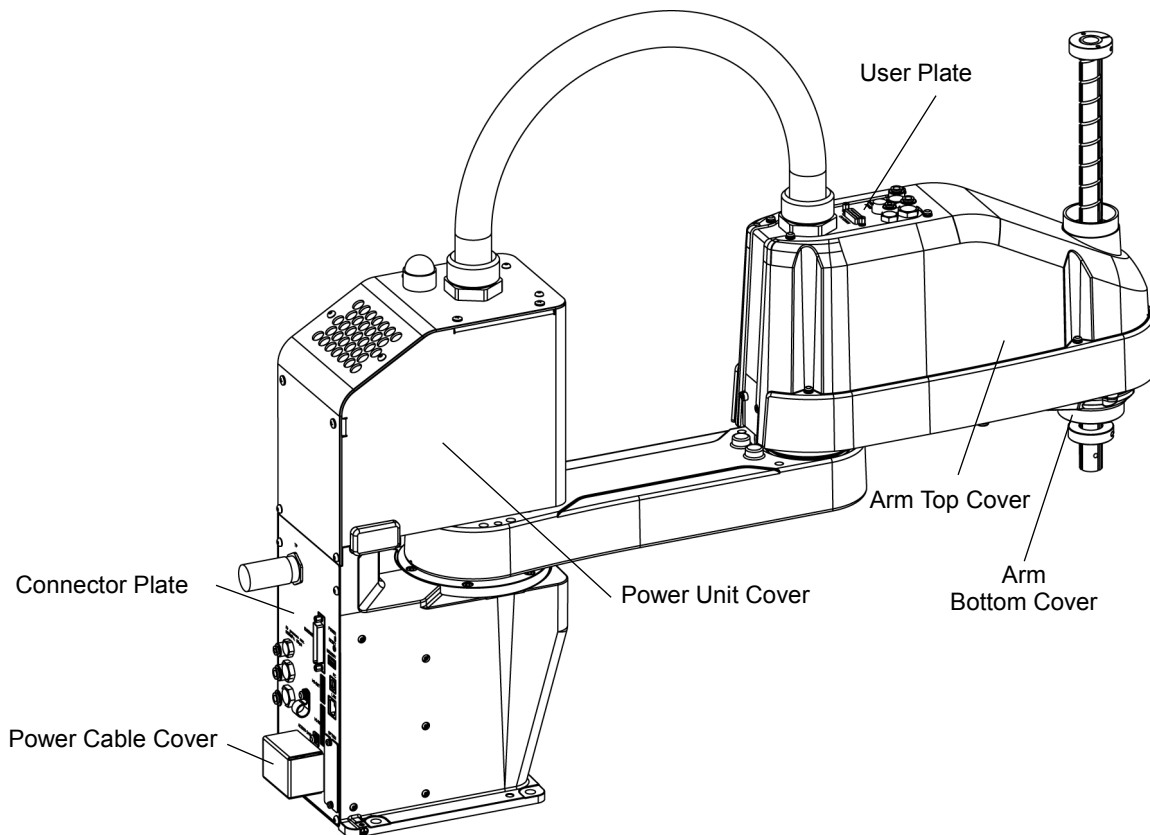

## 7.1 Arm Top Cover



- Do not remove the arm top cover forcibly. Removing the cover forcibly may result in damage to the cables, disconnection, and/or contact failure. Damaged cables, disconnection, or contact failure is extremely hazardous and may result in electric shock and/or improper function of the robot system.
- When installing the cover, be careful not to allow the cables to interfere with the cover mounting and do not bend these cables forcibly to push them into the cover. Unnecessary strain on cables may result in damage to the cables, disconnection, and/or contact failure. Damaged cables, disconnection, or contact failure is extremely hazardous and may result in electric shock and/or improper function of the robot system.  
When routing the cables, observe the cable locations after removing the cover. Be sure to place the cables back to their original locations.

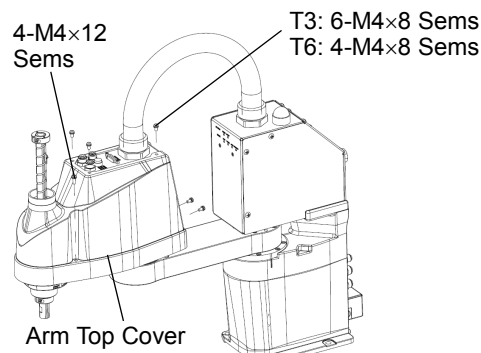

### Arm Top Cover Removal

Unscrew the Arm Top Cover mounting bolts, and then lift the cover.



**NOTE** Be careful for user wires and tubes when removing the cover.

### Arm Top Cover Installation

Put the arm top cover to the arm and secure with the Arm Top Cover mounting bolts. After securing the Arm Top Cover, make sure that the lower limit mechanical stop is not touching the cylindrical part of the Arm Top Cover.

## 7.2 Arm Bottom Cover

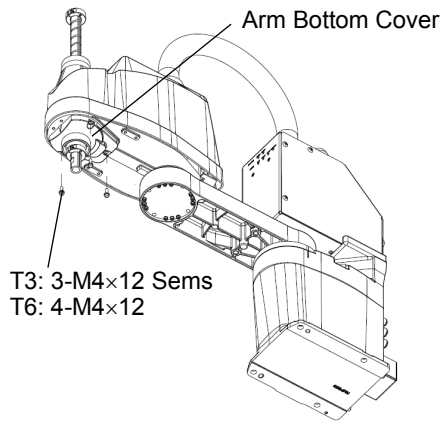

Unscrew the Arm Bottom Cover mounting bolts and then remove the cover.

Be careful of the end effector. When the end effector is installed, the Arm Bottom Cover may not be removed from the shaft

**NOTE**  When you replace the ball screw spline unit, you need to remove the end effector to remove the Arm Bottom Cover completely.

When you can work (maintenance, inspection) without removing the cover completely, move the shaft to the lower limit and lower the Arm Bottom Cover.

## 7.3 Power Cable Cover

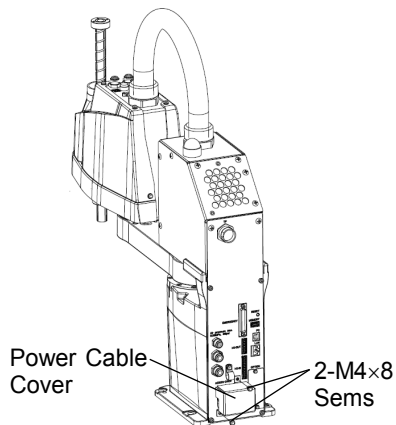

Unscrew the Power Cable Cover mounting bolts and then remove the Power Cable Cover.

## 7.4 Connector Plate



- Do not remove the connector plate forcibly. Removing the connector plate forcibly may result in damage to the cables, disconnection, and/or contact failure. Damaged cables, disconnection, or contact failure is extremely hazardous and may result in electric shock and/or improper function of the robot system.
  - When installing the connector plate, be careful not to allow the cables to interfere with the plate mounting and do not bend these cables forcibly to push them into the cover. Unnecessary strain on cables may result in damage to the cables, disconnection, and/or contact failure. Damaged cables, disconnection, or contact failure is extremely hazardous and may result in electric shock and/or improper function of the robot system.
- When routing the cables, observe the cable locations after removing the connector plate. Be sure to place the cables back to their original locations.

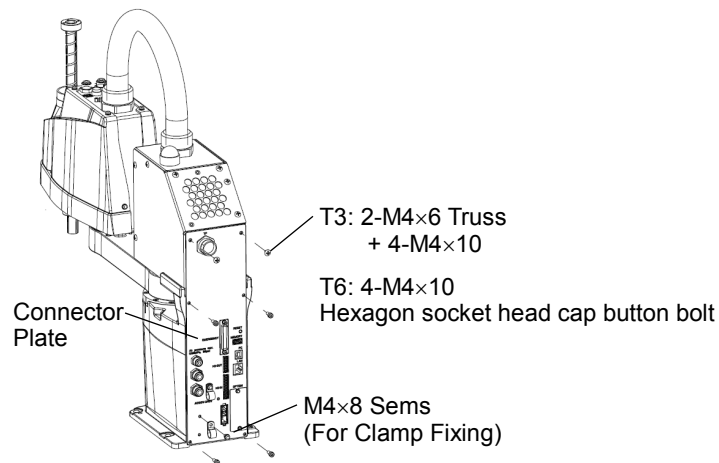

### Connector Plate Removal

- (1) Remove the Power Cable Cover.

Refer to *Maintenance: 7.3 Power Cable Cover*.

- (2) Remove Power cable clamp and then remove Power cable connector.

NOTE  When removing the Power cable connector, pull it out with pushing latches on both side of the connector.

- (3) Unscrew the Connector Plate mounting bolts and then remove the Connector Plate.

NOTE  Some fixed bolts are the same as Power unit cover fixing bolts.

NOTE  Position of the fittings and size of the connector plate are different between T6 and T3. Position and size of screws is the common. The above illustration is T3.

- Connector Plate Installation
- (1) Put the Connector Plate to the base and secure using the mounting bolts.  
Hexagon socket head cap button bolt  
Tightening torque:  $2.0 \pm 0.1$  N·m
  - (2) Connect power cable connector and install power cable clamp.
  - (3) Mount the power cable cover.  
Refer to *Maintenance: 7.3 Power Cable Cover*.



When installing the Connector Plate, be careful of the following.

Prevent the air tube from bending sharply inside the manipulator. Also, do not block the air flow.

If there is a kink in the air tube, air flow is blocked while the manipulator is operating and may cause a trouble.

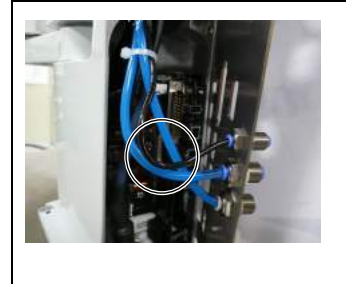

## 7.5 Power Unit Cover

T3

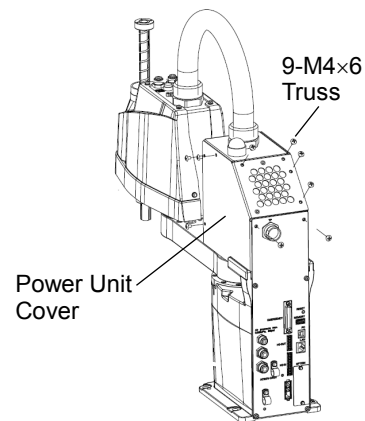

**NOTE**  Unscrew the Power Unit Cover mounting bolts, and then remove the Power Unit Cover. Some fixed bolts are the same as Connector plate fixing bolts.

T6

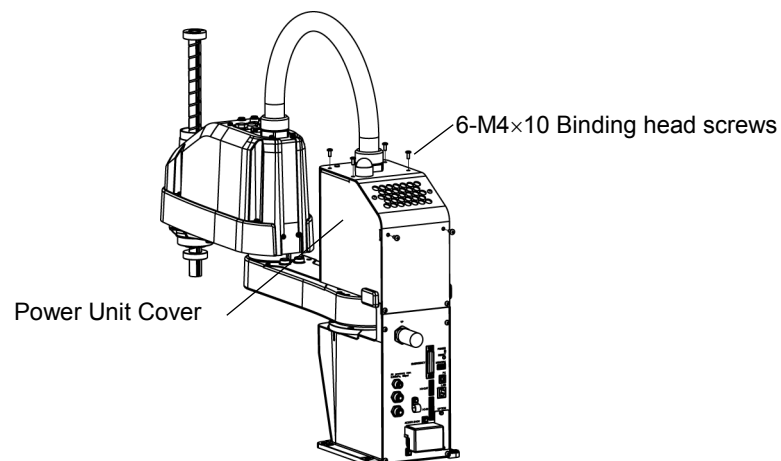

**NOTE**  Unscrew the Power Unit Cover mounting bolts, and then remove the Power Unit Cover. After unscrewing the bolts, make sure to pull the Power Unit Cover to the front of the robot and remove it.

## 7.6 Base Side Cover



CAUTION

- Do not remove the base side cover forcibly. Removing the base side cover forcibly may result in damage to the cables, disconnection, and/or contact failure. Damaged cables, disconnection, or contact failure is extremely hazardous and may result in electric shock and/or improper function of the robot system.
- When installing the base side cover, be careful not to allow the cables to interfere with the plate mounting and do not bend these cables forcibly to push them into the cover.  
Unnecessary strain on cables may result in damage to the cables, disconnection, and/or contact failure. Damaged cables, disconnection, or contact failure is extremely hazardous and may result in electric shock and/or improper function of the robot system.  
When routing the cables, observe the cable locations after removing the connector plate. Be sure to place the cables back to their original locations.

T3

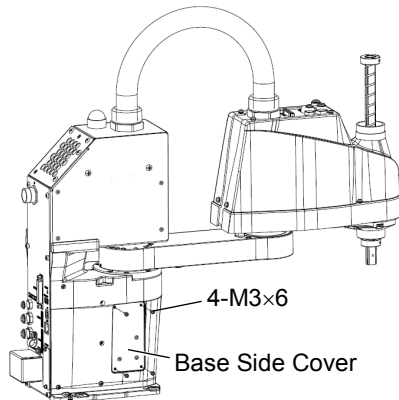

Unscrew the Base Side Cover mounting bolts, and then remove the Base Side Cover.

NOTE



T6

There is no base side cover.



## 7.7 User Plate



CAUTION

- Do not remove the user plate forcibly. Removing the user plate forcibly may result in damage to the cables, disconnection, and/or contact failure. Damaged cables, disconnection, or contact failure is extremely hazardous and may result in electric shock and/or improper function of the robot system.
- When installing the user plate, be careful not to allow the cables to interfere with the plate mounting and do not bend these cables forcibly to push them into the cover.  
Unnecessary strain on cables may result in damage to the cables, disconnection, and/or contact failure. Damaged cables, disconnection, or contact failure is extremely hazardous and may result in electric shock and/or improper function of the robot system.  
When routing the cables, observe the cable locations after removing the connector plate. Be sure to place the cables back to their original locations.

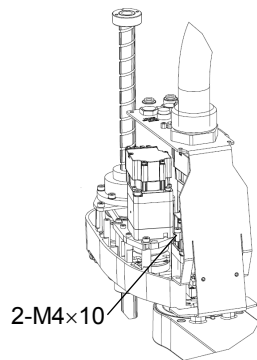

User  
Plate  
Removal

- (1) Remove the Arm Top Cover.  
Refer to *Maintenance: 7.1 Arm Top Cover*.
- (2) Unscrew the User Plate mounting bolts and remove the plate.

User  
Plate  
Installation

- (1) Put the User Plate to the arm and secure using the mounting bolts.
- (2) Mount the Arm Top Cover.  
Refer to *Maintenance: 7.1 Arm Top Cover*.

## 8. Cable

 WARNING	<ul style="list-style-type: none"> <li>■ Do not connect or disconnect the motor connectors while the power to the robot system is turned ON. Connecting or disconnecting the motor connectors with the power ON is extremely hazardous and may result in serious bodily injury as the Manipulator may move abnormally, and also may result in electric shock and/or malfunction of the robot system.</li> <li>■ To shut off power to the robot system, disconnect the power plug from the power source. Be sure to connect the AC power cable to a power receptacle. DO NOT connect it directly to a factory power source.</li> <li>■ Before performing any replacement procedure, turn OFF the Controller and related equipment, and then disconnect the power plug from the power source. Performing any replacement procedure with the power ON is extremely hazardous and may result in electric shock and/or malfunction of the robot system.</li> <li>■ Be careful not to get any foreign substances in the Manipulator, connectors, and pins during maintenance. Turning ON the power to the robot system when any foreign substances exist in them is extremely hazardous and may result in electric shock and/or malfunction of the robot system.</li> </ul>
--	---

 CAUTION	<ul style="list-style-type: none"> <li>■ Be sure to connect the cables properly. Do not allow unnecessary strain on the cables. (Do not put heavy objects on the cables. Do not bend or pull the cables forcibly.) The unnecessary strain on the cables may result in damage to the cables, disconnection, and/or contact failure. Damaged cables, disconnection, or contact failure is extremely hazardous and may result in electric shock and/or improper function of the robot system.</li> </ul>
--	---

### 8.1 Replacing Cable Unit

	Name	Quantity	Note	
Maintenance part	Cable unit	1	T3: 2182565 T6: 2190924	
Tools	Hexagonal wrench	width across flats: 2 mm	1	For M3 button volt
		width across flats: 2.5 mm	1	For M3 screw, M4 button bolt
		width across flats: 3 mm	1	For M4 screw
	Spanner	width across flats: 5 mm	1	For hand I/O connector removal
	Nut screwdriver	width across flats: 5 mm	1	For hand I/O connector removal
	Torque wrench		1	
	Cross-point screwdriver (No. 2)		1	For cross-recessed screw
	Nippers	1	For cutting wire tie	
Material	Wire tie	-		

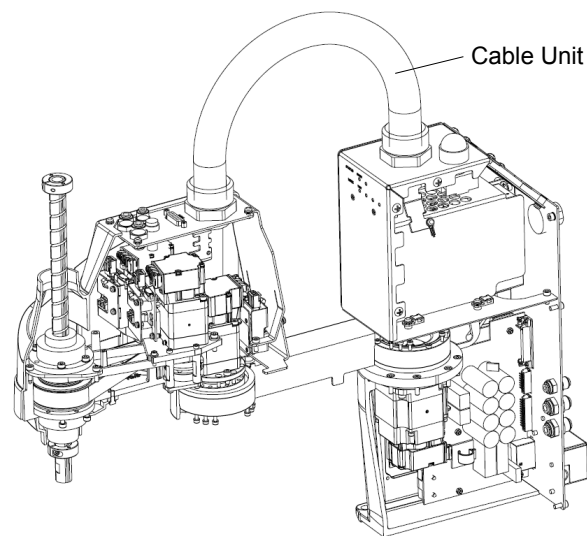

(Illustration: T3-401S)



- If the connectors have been disconnected during the replacement of the cable unit, be sure to reconnect the connectors to their proper positions. Refer to the wiring diagrams.  
Improper connection of the connectors may result in improper function of the robot system.  
For details on the connections, refer to *Maintenance: 3. Manipulator Structure*.
- When installing the cover, be careful not to allow the cables to interfere with the cover mounting and do not bend these cables forcibly to push them into the cover. Unnecessary strain on cables may result in damage to the cables, disconnection, and/or contact failure. Damaged cables, disconnection, or contact failure is extremely hazardous and may result in electric shock and/or improper function of the robot system.  
When routing the cables, observe the cable locations after removing the cover. Be sure to place the cables back to their original locations.
- Be sure to connect the cables properly. Do not allow unnecessary strain on the cables. (Do not put heavy objects on the cables. Do not bend or pull the cables forcibly.) The unnecessary strain on the cables may result in damage to the cables, disconnection, and/or contact failure. Damaged cables, disconnection, or contact failure is extremely hazardous and may result in electric shock and/or improper function of the robot system.

**NOTE**  A brake is mounted on the Joint #3 motor to prevent the shaft from lowering down due to the weight of the end effector while the power to the Manipulator is OFF or while the motor is in OFF status (MOTOR OFF).

Move the shaft down to its lower limit before the replacement procedure following the removal steps.

Cable Unit Removal

- (1) Turn ON the Manipulator and change the motor to OFF status (MOTOR OFF).
- (2) Press and hold the brake release switch to let the shaft down. Be sure to keep enough space and prevent the end effector hitting any peripheral equipment.

The brake release switch affects only Joint #3. When the brake release switch is pressed, the Joint #3 brake is released.

Be careful of the shaft while the brake release switch is being pressed because the shaft may be lowered by the weight of an end effector.

- (3) Turn OFF the manipulator.
- (4) Remove the Power Unit Cover.

For details, refer to *Maintenance: 7.5 Power Unit Cover*.

- (5) Remove the ground wire that secured on the case side cable fixing plate.
- (6) Cut off the wire tie binding the cables in the Base side.
- (7) Remove the connector plate.

Reference: *Maintenance: 7.4 Connector Plate*

- (8) Remove the following part that connected to the Connector Plate (inside).

Air tube  
TP connector

- (9) T3: Remove the base side cover.

For details, refer to *Maintenance: 7.6 Base Side Cover*.

- T6: Remove the connector of regenerative resistor junction cable.

Unscrew the mounting bolts of the joint #1 AMP board plate and the regenerative resistor plate.

Mounting bolts: 4-M4×8 Sems

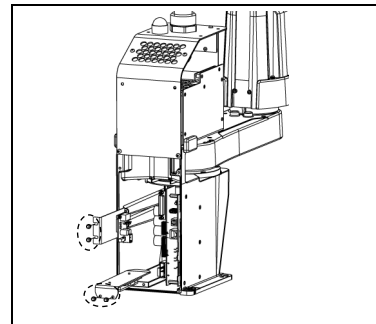

- (10) Remove the connector of AMP board.

A: Power cable connector  
B: Signal cable connector  
C: Motor connector

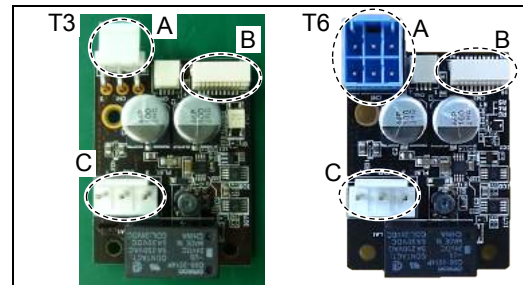

(11) Unscrew the CPU/DPB board mounting screw.

Hexagon socket head cap button bolt: 5-M3×5

Remove the CPU/DPB board from base.

**NOTE**  Radiation sheet is attached on back of the CPU/DPB boards. Be careful not to brake or lose it.

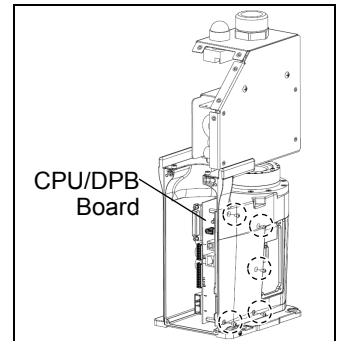

(12) Remove CPU/DPB board connector.

A: Power connector (IN/OUT ×1 for each)

B: Power cable connector (×2)

C: Signal cable connector

D: Hand I/O connector

E: LED connector

F: Regenerative resistor connector 1 (T6 only)

G: Regenerative resistor connector 2 (T6 only)

**NOTE**  Remember the cable layout for reconnecting the cables correctly after replacement.

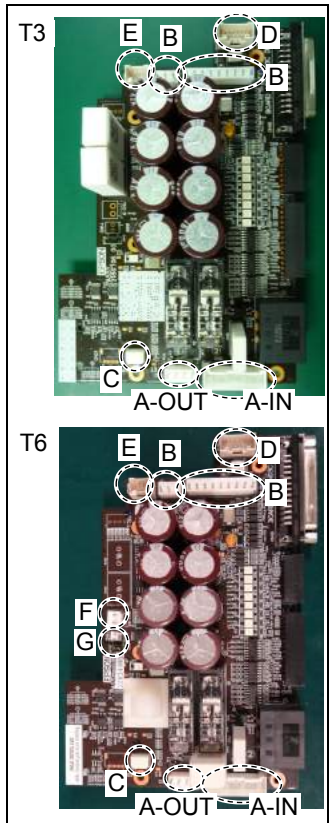

(13) Remove the Arm Top Cover.

For details, refer to *Maintenance: 7.1 Arm Top Cover*.

(14) Remove the User Plate.

For details, refer to *Maintenance: 7.7 User Plate*.

(15) T3: Remove the motor unit connectors of Joint 2, 3, and 4.

A: Power cable connector

B: Signal cable connector (IN/OUT ×1 for each)

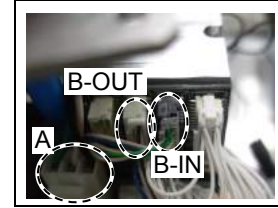

NOTE



Signal cable for joint #4 is IN only.

T6: Remove the connector of AMP board unit and the motor unit connectors of Joint 2, 3, and 4.

Motor Unit

Signal cable connector (IN/OUT ×1 for each)

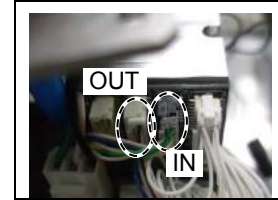

NOTE



Signal cable for joint #4 is IN only.

AMP board unit

Power cable connector (total: 3 connectors)

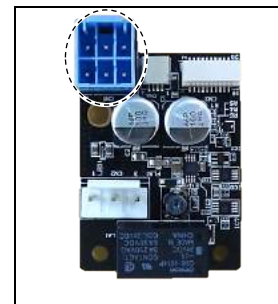

(16) Disconnect the Hand I/O cable and air tube from the User Plate.

NOTE



Mounting screws for the Hand I/O cable are very small. Be sure to keep the screws.

Press the ring on the fittings to pull out the air tube. (ø6×2, ø4×1)

Remember the cable layout for reconnecting the disconnected parts after replacement.

(17) Remove the ground wire that secured on the user plate.

(18) Cut off the wire tie binding the cables in the Arm side.

(19) Remove the nut that secures the cable duct fittings to the User Plate and pull out the cables from the User Plate.

(20) Remove the nut that secures the cable duct fittings to the Base.

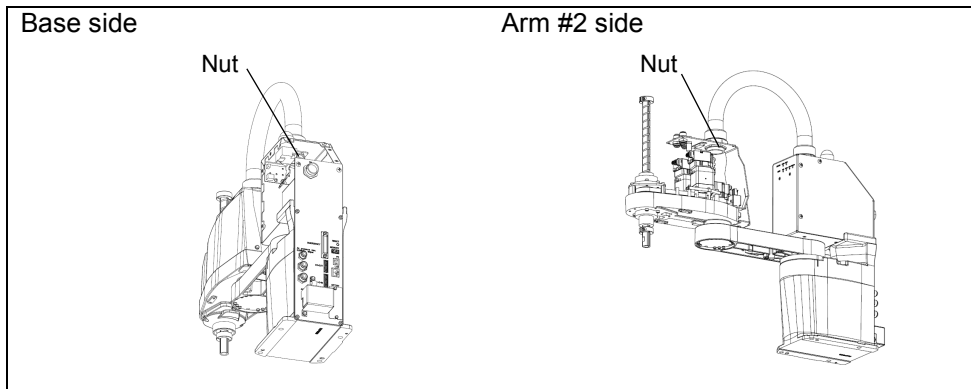

Cable Unit  
Installation

- (1) Pass the new cables through the Base, cable fixing plate, and nut, and turn the fittings to secure the cables.
- (2) Pass the cables in the User Plate side through the User Plate and nut and turn the fittings to secure the cables.
- (3) Connect the following parts to User Plate.

Air tube  
Hand I/O cable

- (4) T3: Connect the motor unit connectors of Joint 2, 3, and 4.

A: Power cable connector  
B: Signal cable connector (IN/OUT ×1 for each)

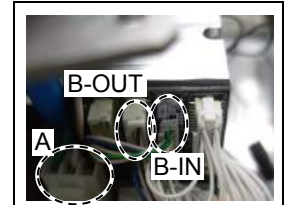

## NOTE



Signal cable for joint #4 is IN only.

- T6: Connect connector of AMP board unit and the motor unit connectors of Joint 2, 3, and 4.

Motor Unit  
Signal cable connector (IN/OUT ×1 for each)

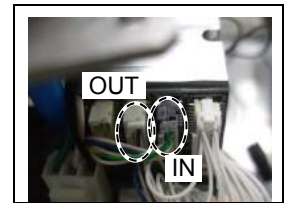

## NOTE



Signal cable for joint #4 is IN only.

AMP board unit  
Power cable connector (total: 3 connectors)

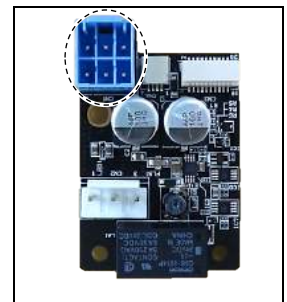

- (5) Mount the User Plate.

For details, refer to *Maintenance: 7.7 User Plate*.

- (6) Connect the ground wire on the Arm side to the User Plate.
- (7) Bind the cables with a wire tie as removed in the removal step (18).
- (8) Connect the ground wire on the Base side to the cable fixing plate on the Base side.

(9) Connect CPU/DPB board connector.

- A: Power connector (IN/OUT ×1 for each)
- B: Power cable connector (×2)
- C: Signal cable connector
- D: Hand I/O connector
- E: LED connector
- F: Regenerative resistor connector 1 (T6 only)
- G: Regenerative resistor connector 2 (T6 only)

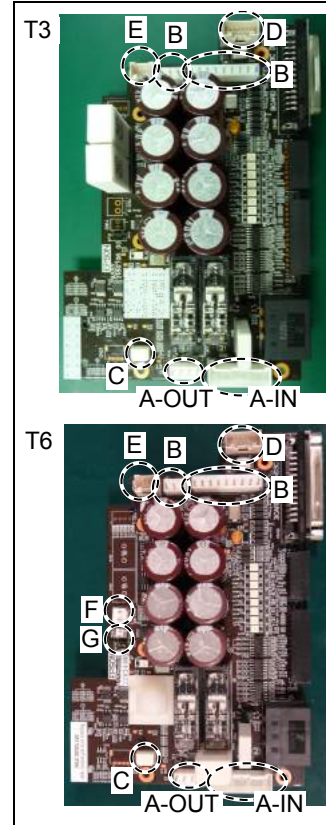

(10) Mount CPU/DPB board on the base.

Hexagon socket head cap button bolt: 5-M3×5  
 Tightening torque: 0.45 ± 0.1 N·m

**NOTE** Attach the radiation sheet on back of the CPU/DPB boards when mounting.

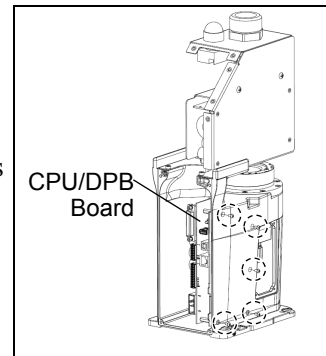

(11) Connect the following parts that connected to the Connector Plate.

- Air tube
- TP connector

(12) Connect AMP board connector.

- A: Power cable connector
- B: Signal cable connector
- C: Motor connector

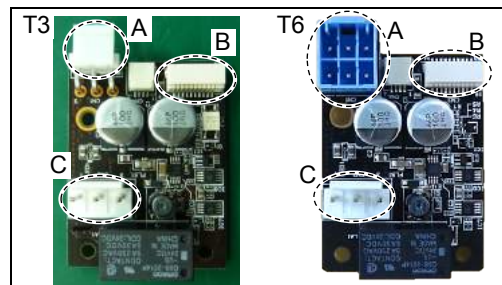

(13) T3: Mount Base Side Cover.

For details, refer to *Maintenance: 7.6 Base Side Cover*.



T6: Mount the joint #1 AMP board plate and the regenerative resistor plate.

Connect the connector of regenerative resistor junction cable.

Mounting bolts: 4-M4×8 Sems

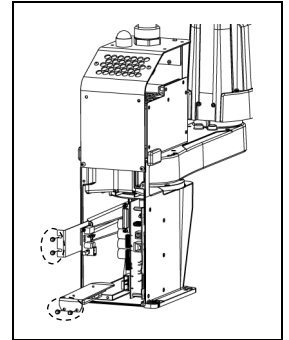

(14) Bind the cables with a wire tie as removed in the removal step (6).

(15) Place and secure the Arm Top Cover without the cables being stuck.

For details, refer to *Maintenance: 7.1 Arm Top Cover*.

(16) Mount Power Unit Cover.

For details, refer to *Maintenance: 7.5 Power Unit Cover*.

(17) Mount Connector Plate.

For details, refer to *Maintenance: 7.4 Connector Plate*.

## 8.2 Insert or Pull out of Power Cable

	Name	Quantity	Note
Tools	Cross-point screwdriver (No. 2)	1	For cross-recessed screw

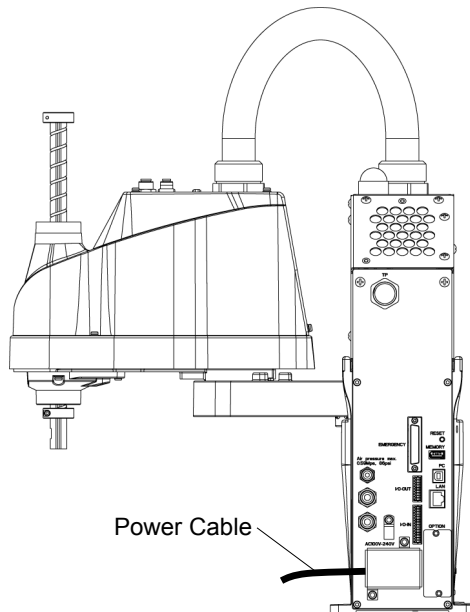

### Power Cable Removal

- (1) Turn OFF the Manipulator.
- (2) Remove the Power Cable Cover.

For details, refer to *Maintenance: 7.3 Power Cable Cover*.

- (3) Remove Power cable clamp and then remove Power cable connector.

NOTE When removing the Power cable connector, pull it out with pushing latches on both sides of the connector.



### Power Cable Installation

- (1) Connect the Power cable connector and mount Power cable clamp.
- (2) Mount Power cable cover.

For details, refer to *Maintenance: 7.3 Power Cable Cover*.

## 9. Joint #1



- Do not connect or disconnect the motor connectors while the power to the robot system is turned ON. Connecting or disconnecting the motor connectors with the power ON is extremely hazardous and may result in serious bodily injury as the Manipulator may move abnormally, and also may result in electric shock and/or malfunction of the robot system.
- To shut off power to the robot system, disconnect the power plug from the power source. Be sure to connect the AC power cable to a power receptacle. DO NOT connect it directly to a factory power source.
- Before performing any replacement procedure, turn OFF the Controller and related equipment, and then disconnect the power plug from the power source. Performing any replacement procedure with the power ON is extremely hazardous and may result in electric shock and/or malfunction of the robot system.



- Be careful not to apply excessive shock to the motor shaft when replacing the motors. The shock may shorten the life cycle of the motors and encoder and/or damage them.
- Never disassemble the motor and encoder. A disassembled motor and encoder will cause a positional gap and cannot be used again.

After parts have been replaced (motors, reduction gear units, a brake, timing belts, ball screw spline unit, etc.), the Manipulator cannot operate properly because a mismatch exists between the origin stored in each motor and its corresponding origin stored in the Robot system.

Because of that, it is necessary to perform calibration (encoder rest and calibration) to match these origins.

Refer to *Maintenance 16. Calibration* to execute the calibration.

T3

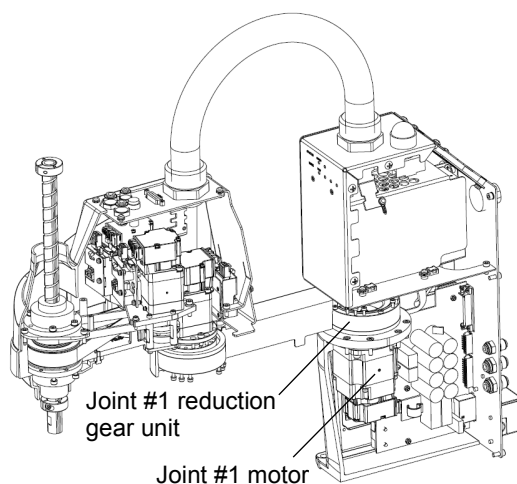

T6

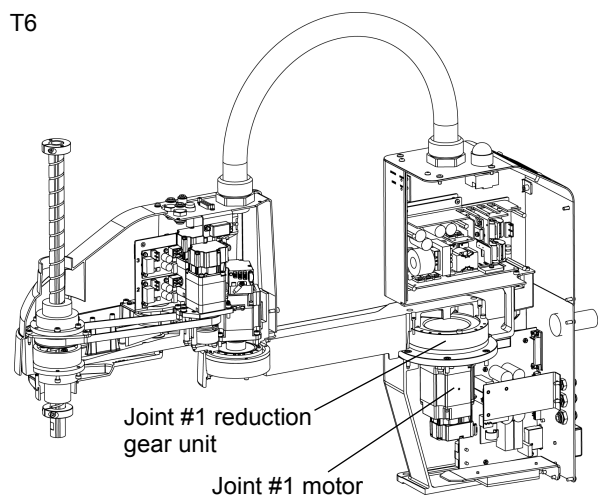

### 9.1 Replacing Joint #1 Motor

		Name	Quantity	Note
Maintenance parts	Motor	200W	1	T3: 2182560
		300W	1	T6: 2190962
	O-ring	Between reduction gear unit and Arm #1	1	T3: 1213266 T6: 1510528
		Between reduction gear unit and flange	1	T3: 1653819 T6: 1650901
		Between flanges	1	T6: 1213266
		Between motor and flange	1	T3: 1709549 T6: 1520371
Tools	Hexagonal wrench	width across flats: 2 mm	1	For M4 set screw For M3 button bolt
		width across flats: 2.5 mm	1	For M3 set screw For M4 button bolt
		width across flats: 3 mm	1	For M4 screw
		width across flats: 3 mm	1	For M5 screw
		Torque wrench	1	
		Cross-point screwdriver (No. 2)	1	For cross-recessed screw
		Wiping cloth	1	For wiping grease
Grease	Grease	SK-2	-	For T3
		SK-1A	-	For T6

**Joint #1 motor Removal**

(1) Turn OFF the Manipulator.

(2) Remove the Power Unit Cover.

For details, refer to *Maintenance: 7.5 Power Unit Cover.*

(3) Remove the Connector Plate.

For details, refer to *Maintenance: 7.4 Connector Plate*

(4) Remove the following parts that connected to the Connector Plate (inside).

Air tube

TP connector

(5) T3: Remove the Base Side Cover.

For details, refer to *Maintenance: 7.6 Base Side Cover.*

T6: Remove the AMP board plate of joint #1.

2-M4×8 Sems

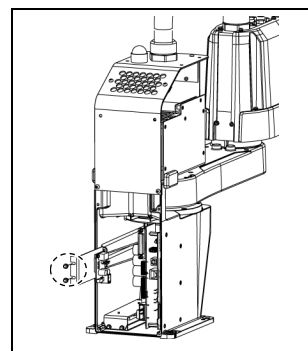

- (6) Remove the connector of AMP board.

A: Power cable connector  
 B: Signal cable connector  
 C: Motor connector

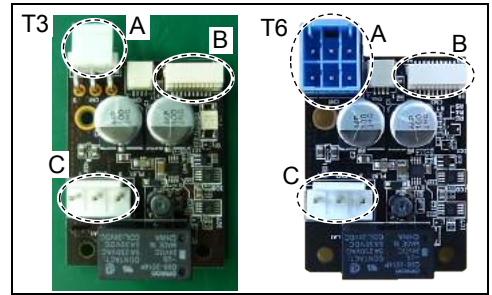

- (7) Remove the AMP board.

3-M3×6 Sems



T3: There is no radiation sheet.

T6: Radiation sheet is attached on the back side of the AMP board. Be careful not to lose or break it.

T6: Disconnect the connector of regenerative resistor junction cable. Then, remove the regenerative resistor fixing plate.

2-M4×8 Sems

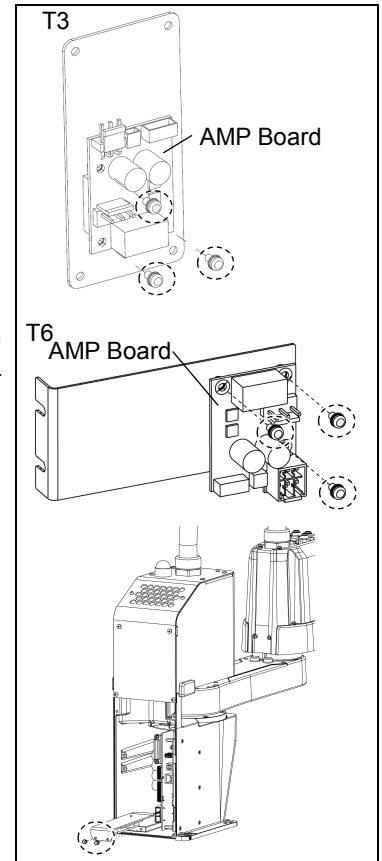

- (8) Unscrew CPU/DPB board mounting screws,  
 Hexagon socket head cap button bolt: 5-M3×5

Remove CPU/DPB board from a base.



Radiation sheet is attached on the back of CPU/DPB board. Be careful not to break or lose it.

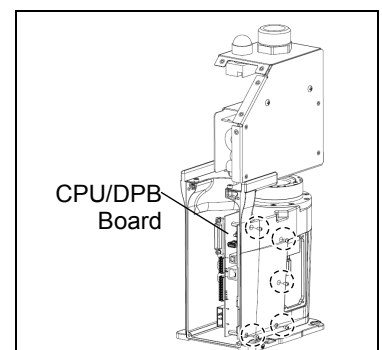

(9) Remove the CPU/DPB board connector.

- A: Power connector (IN/OUT ×1 for each)
- B: Power cable connector (×2)
- C: Signal cable connector
- D: Hand I/O connector
- E: LED connector
- F: Regenerative resistor 1 (T6 only)
- G: Regenerative resistor 2 (T6 only)



Remember the cable layout for reconnecting the cables correctly after replacement.

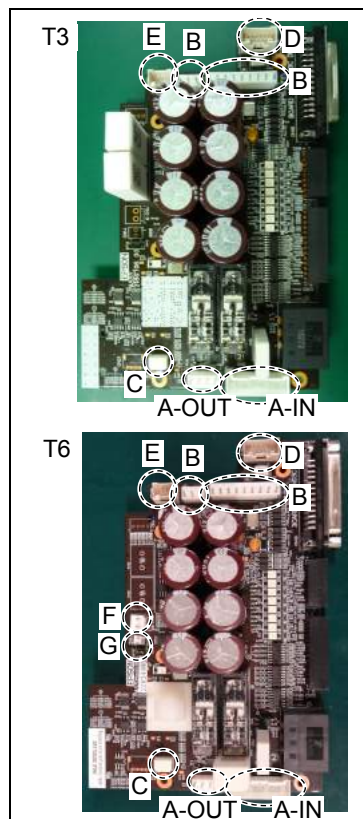

(10) Remove the connector of the Joint #1 motor unit.

- Signal cable connector (IN/OUT ×1 for each)

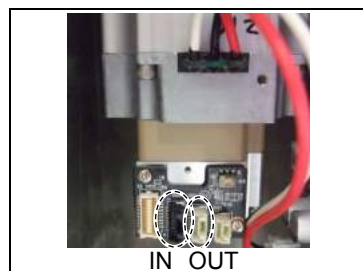

(11) T3: Remove the Power board cover.

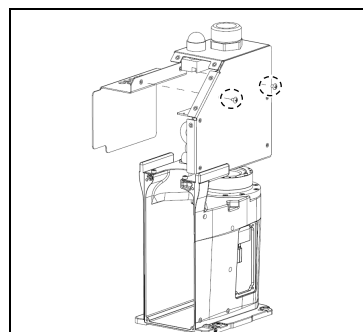

T6: Remove the LED Board Connector.

A: LED - .LED Board Connector.

Cut off the wire tie binding the internal cables.  
Then, remove the top board.

Hexagon socket head cap button bolt: 4-M4×10

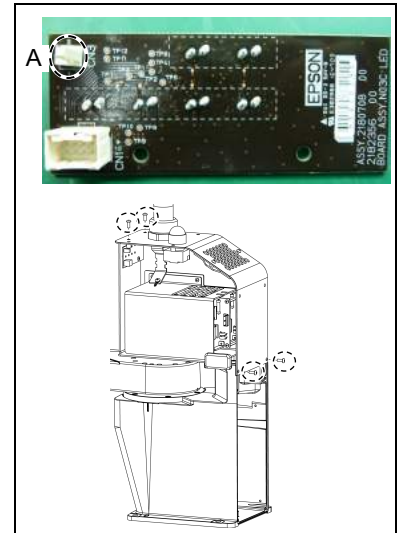

(12) Unscrew the Power unit mounting screws.

T3: 3-M4×10

T6: 4-M4×10

Remove Power unit from the base.

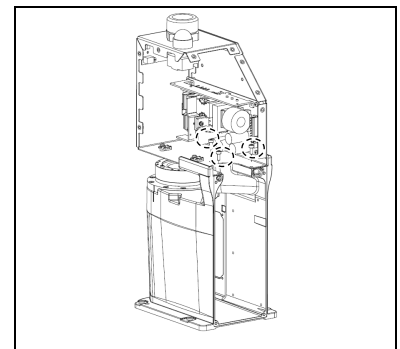

(13) Remove the Arm #1 mounting bolt in the Joint #1 side and remove the arm.

T3: A: 8-M3×30  
B: 4-M3×15

T6: A: 8-M4×40  
B: 4-M3×20

There is an O-ring (between the reduction gear unit and Arm #1) between the Joint #1 unit and the arm. Be sure to keep the O-ring

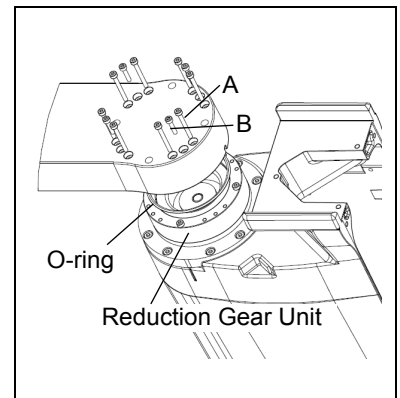

(14) Remove the screws mounting the Joint #1 flange on the Base.

T3: 8-M4×15

T6: 6-M5×15

Remove the Joint #1 motor unit from the base.

NOTE  

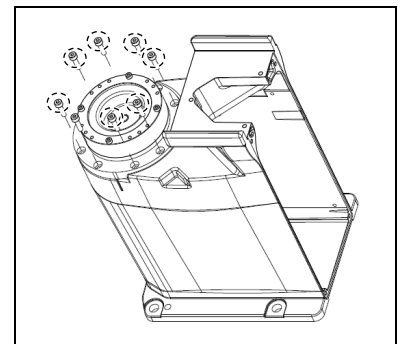

When removing the Joint #1 motor unit, pull it up slowly to avoid hitting the base.



(15) T3: Loosen the motor mounting screws on the Joint #1 motor flange and remove the motor unit.

4-M4×15+small washer

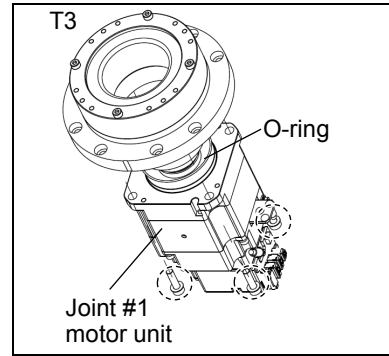
There is an O-ring (between the motor and flange) between the motor and Joint #1 motor flange. Be sure to keep the O-ring



T6: Loosen the motor flange mounting screws on the Joint #1 motor flange and remove the motor unit.

4-M4×12

There is an O-ring (between the flange) between the motor and Joint #1 motor flange. Be sure to keep the O-ring

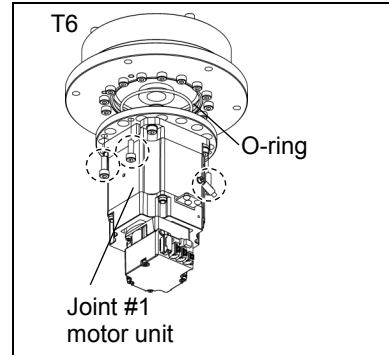

(16) Remove the waveform generator from the Joint #1 motor.

There is a brass bushing in one of the set screw holes. Be sure to keep the bushing.

T3: A: Brass Bushing M4  
B: Set Screw 2-M4×6

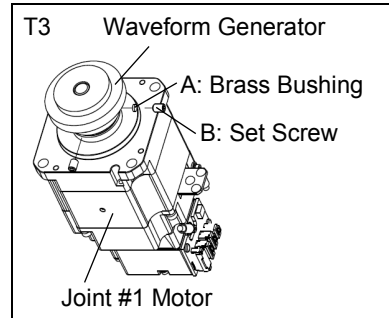

T6: A: Brass Bushing M5  
B: Set Screw 2-M5×6

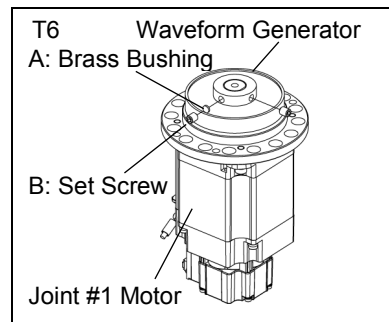

(17) T6: Unscrew the motor mounting screws. Then, remove the motor flange and O ring.

4-M4×12+ small washer

There is an O-ring (between the motor and flange) between the motor and motor flange. Be sure to keep the O-ring

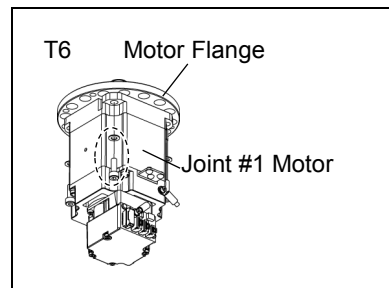

NOTE

T3: There is no motor flange.



(18) Remove the motor ground wire.

Hexagon socket head cap bolt with washer: 2-M2x5

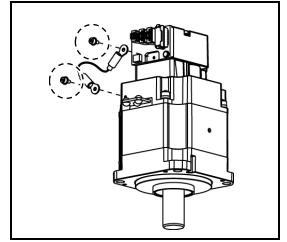

Joint #1 motor  
Installation

- (1) Connect the motor ground wire to the motor.  
Hexagon socket head cap bolt with washer: 2-M2×5  
Tightening torque: 0.2 ± 0.05 N·

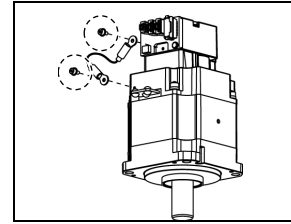

- (2) T6: Set an O-ring (between the motor and flange) on the motor mounting surface and install the motor flange.  
4-M4×12+ small washer

NOTE

T3: There is no motor flange.

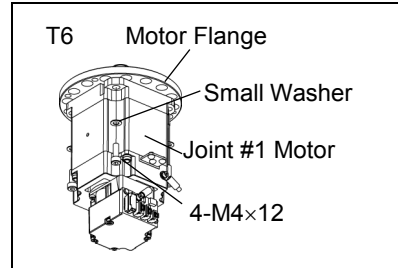

- (3) Apply grease to the between the waveform generator and motor. Mount the waveform generator on the Joint #1 motor.

Be sure to align the end face of the waveform generator to the end face of the motor shaft. Tighten one of the set screws vertically on the flat face of the motor shaft. Insert a bushing into the other set screw hole to prevent damage to the motor shaft.

- T3: Grease volume: SK-2: 4 g  
A: Brass Bushing : M4  
B: Set Screw : 2-M4×6

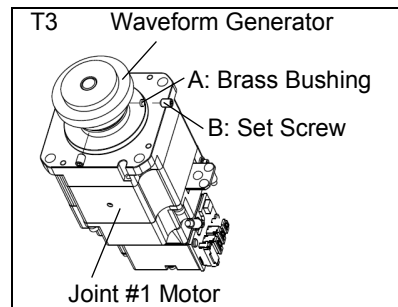

- T6: Grease volume: SK1-A: 13g  
A: Brass Bushing : M5  
B: Set Screw : 2-M5×6

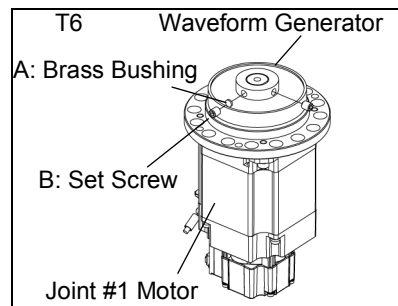

■ See the figure above for the orientation of the waveform generator. Be sure to install the waveform generator properly. Improper installation of the waveform generator will result in improper function of the Manipulator.

- (4) T3: Set an O-ring (between the motor and flange) on the motor mounting surface and assemble the motor with the Joint #1 flange.

4-M4×15+ small washer

- T6: Set an O-ring (between the flanges) on the motor mounting surface and install the motor flange.

4-M4×12

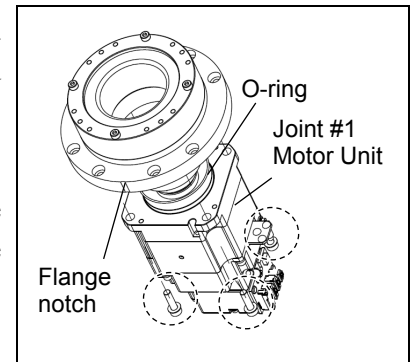

**NOTE**



Be careful about flange notch and motor position when mounting the flange.

To insert the motor, turn it slowly from side to side by hand and push in

Replace O-ring to new one if there is swelling, scratch, or wear.

- (5) Mount the Joint #1 unit on the Base.

Secure the Joint #1 motor cables facing toward the back of the Base.

- (6) Set the O-ring removed in the removal step (10) into the O-ring (between reduction gear unit and Arm #1) groove of the arm.

Replace O-ring to new one if there is swelling, scratch, or wear.

- (7) Mount the arm to the Joint #1 unit.

Loosely fasten all bolts in a crisscross pattern so that the bolts will be fastened evenly.

T3: A: 8-M3×30

B: 4-M3×15

T6: A: 8-M4×40

B: 4-M3×20

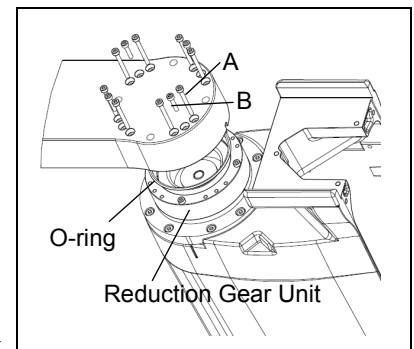

Then, using a torque wrench, tighten each bolt securely in a crisscross pattern at the torque specified in the table below.

Tightening torque:

M3:  $2.4 \pm 0.1$  N·m

M4:  $5.5 \pm 0.25$  N·m

- (8) Mount Power unit to base.

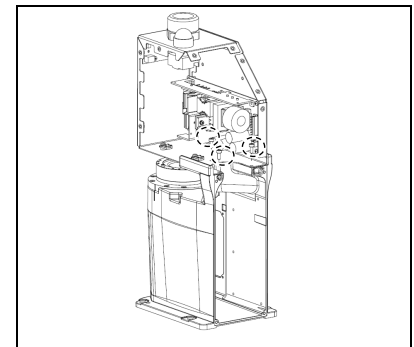

(9) T3: Mount a cover of power board.

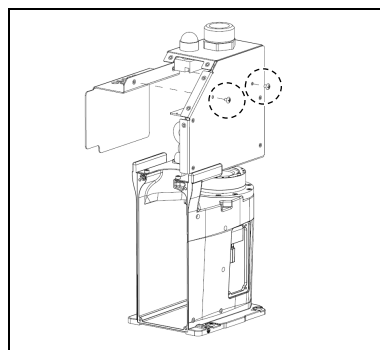

T6: Mount the top board of the power unit.

Hexagon socket head cap button bolt:  
4-M4×10

Tightening torque:  $2.0 \pm 0.1$  N·m

Bind the internal cables with a wire tie as removed in the removal procedure (11).

Connect the LED board connector.

A: LED - .LED Board Connector.

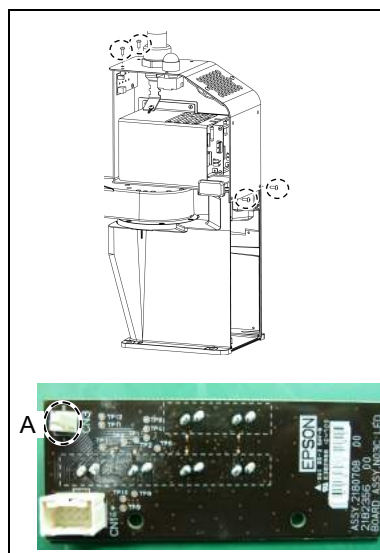

(10) Connect the connector of Joint #1 motor unit.

Signal cable connector (IN/OUT ×1 for each)

(11) Connect CPU/DPB board connector.

A: Power connector (IN/OUT ×1 for each)

B: Power cable connector (×2)

C: Signal cable connector

D: Hand I/O connector

E: LED connector

F: Regenerative resistor 1 (T6 only)

G: Regenerative resistor 1 (T6 only)

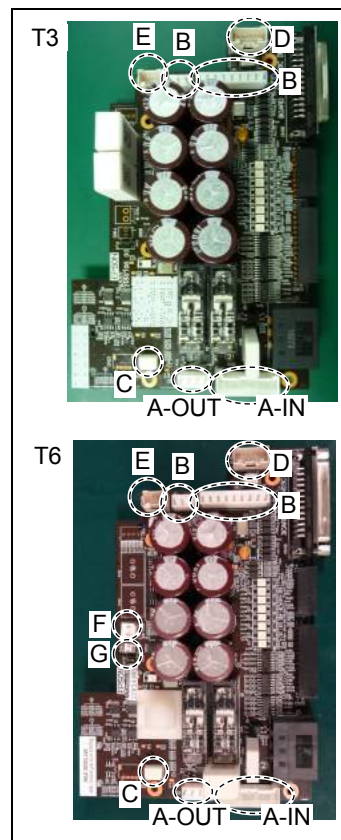

- (12) Mount CPU/DPB board to base.

Hexagon socket head cap button bolt: 5-M3×5

Tightening torque: 0.45±0.1 N·m

**NOTE**  Attach the radiation sheet on the back side of the CPU/DPB boards when mounting.

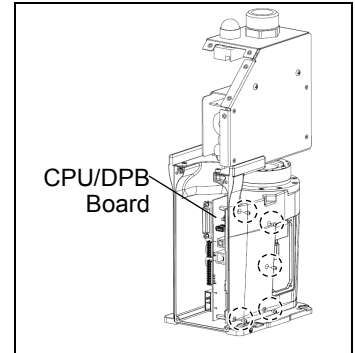

- (13) Mount the AMP board.

T6: Attach the radiation sheet on the back side of the AMP board.

**NOTE**  T3: The radiation sheet is not required.

- (14) Connect AMP board connector.

A: Power cable connector

B: Signal cable connector

C: Motor connector

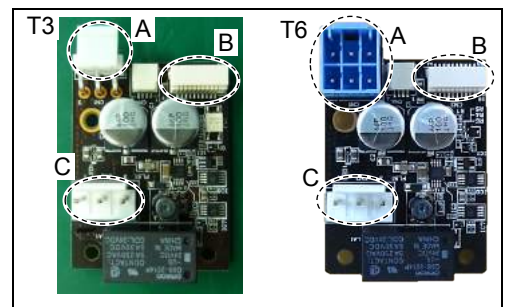

- (15) T3: Mount base side cover.

For details, refer to *Maintenance: 7.6 Base Side Cover*.

T6: Mount the Joint #1 AMP board plate

- (16) Connect the following parts that connected to the Connector Plate.

Air tube

TP connector

- (17) Mount the Power Unit Cover.

For details, refer to *Maintenance: 7.5 Power Unit Cover*.

- (18) Mount the Connector Plate.

For details, refer to *Maintenance: 7.4 Connector Plate*.

- (19) Turn ON the Manipulator.

For details, refer to *Setup & Operation 6.5 LED*

**NOTE**  DO NOT turn OFF the power until the manipulator starts.

- (20) Execute the calibration for the Joint #1.

For details, refer to *Maintenance: 16. Calibration*.

## 9.2 Replacing Joint #1 Reduction Gear Unit

A reduction gear unit consists of the following three parts. When replacing the reduction gear unit, be sure to always replace the waveform generator, flexspline, and circular spline all together as one set.

Waveform generator, Flexspline, Circular spline

For details of the reduction gear unit, refer to *Maintenance 19. Maintenance Parts List*.

	Name		Quantity	Note
Maintenance Part	Reduction Gear Unit		1	T3: 1718303 T6: 1750570
Tools	Hexagonal wrench	width across flats: 2 mm	1	For M4 set screw
		width across flats: 2.5 mm	1	For M3 screw
		width across flats: 3 mm	1	For M4 screw
	Torque wrench		1	
	Nippers		1	
	Spatula		1	For apply grease
	Wiping cloth		1	For wiping grease (Flange)
			1	For wiping grease (Bolt)
Screw (M4)		2	About 20 mm in length For flexspline removal	
Grease	Grease	SK-2	-	For T3
		SK-1A	-	For T6

### Joint #1 Reduction Gear Unit Removal

- (1) Remove the Joint #1 motor unit.

For details, refer to *Maintenance:*

*9.1 Replacing Joint #1 Motor "Removal procedure".*

- (2) Remove the reduction gear unit from the Joint #1 flange.

T3: 10-M3×20

T6: 16-M4×25

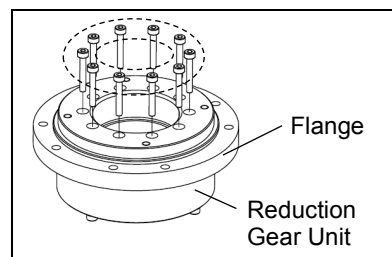

Joint #1  
Reduction  
Gear Unit  
Installation

- (1) A new reduction gear unit contains the parts shown in the picture on the right when it is unpacked.

The gear grooves of the flexspline, circular spline, and the bearings of the waveform generator have been greased. Wipe off excess grease from the mounting surface.

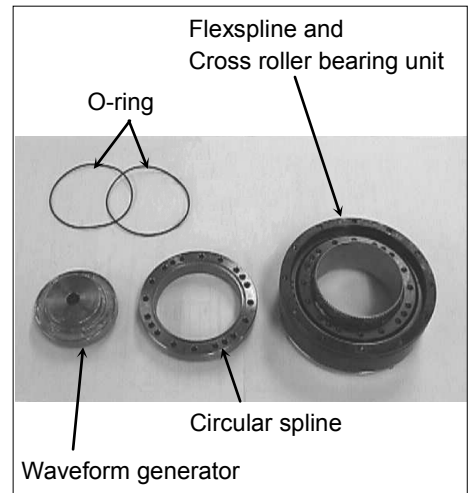

- Never adjust (loosen or tighten) the mounting bolts between the flexspline and cross roller bearing unit. If the mounting bolts are adjusted, the flexspline and cross roller bearing unit must be aligned by the maker of the reduction gear unit.

- (2) Fit the O-rings (between the reduction gear unit and flange) into the grooves on both sides of the new circular spline.

Make sure that the rings do not come out of the grooves.

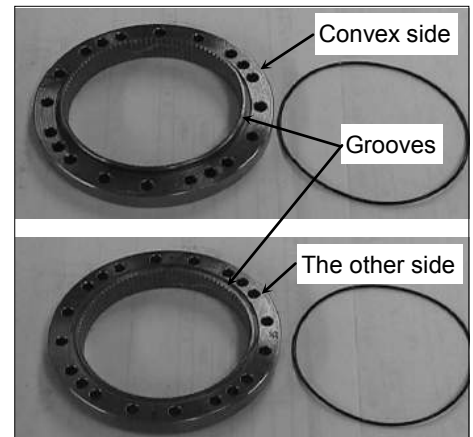

- (3) Face the convex side of the circular spline down, and then fit it into the flexspline.



- (4) Match the screw holes on the inner ring of the cross roller bearing unit and the through holes of the circular spline.



- (5) Secure the reduction gear flange to the circular spline.

10-M3×20

Loosely fasten all bolts in a crisscross pattern so that the bolts will be fastened evenly. Then, using a torque wrench, tighten each bolt securely in a crisscross pattern at the torque specified in the table below.

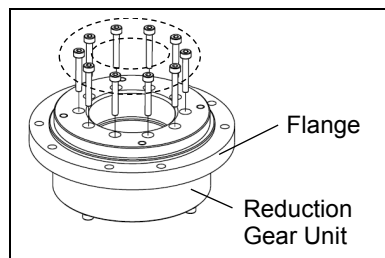

Item	Model	Bolt type	Bolts	Tightening torque
Joint #1 reduction gear unit	T3	M3×20	10	2.4±0.1N·m
	T6	M4×25	16	5.5 ± 0.25 N·m

NOTE



Be careful not to apply too much force since it may damage the parts.

- (6) Apply grease inside the flexspline.

Grease volume T3: SK-2 13 g

T6: SK-1A 37 g

- (7) Mount the Joint #1 motor.

For details, refer to *Maintenance*:

*9.1 Replacing Joint #1 Motor “Installation procedure”.*



## 10. Joint #2



- Do not connect or disconnect the motor connectors while the power to the robot system is turned ON. Connecting or disconnecting the motor connectors with the power ON is extremely hazardous and may result in serious bodily injury as the Manipulator may move abnormally, and also may result in electric shock and/or malfunction of the robot system.
- To shut off power to the robot system, disconnect the power plug from the power source. Be sure to connect the AC power cable to a power receptacle. DO NOT connect it directly to a factory power source.
- Before performing any replacement procedure, turn OFF the Controller and related equipment, and then disconnect the power plug from the power source. Performing any replacement procedure with the power ON is extremely hazardous and may result in electric shock and/or malfunction of the robot system.



- Be careful not to apply excessive shock to the motor shaft when replacing the motors. The shock may shorten the life cycle of the motors and encoder and/or damage them.
- Never disassemble the motor and encoder. A disassembled motor and encoder will cause a positional gap and cannot be used again.

After parts have been replaced (motors, reduction gear units, a brake, timing belts, ball screw spline unit, etc.), the Manipulator cannot operate properly because a mismatch exists between the origin stored in each motor and its corresponding origin stored in the Robot system.

Because of that, it is necessary to perform calibration (encoder rest and calibration) to match these origins.

Refer to *Maintenance: 16. Calibration* to execute the calibration.

T3

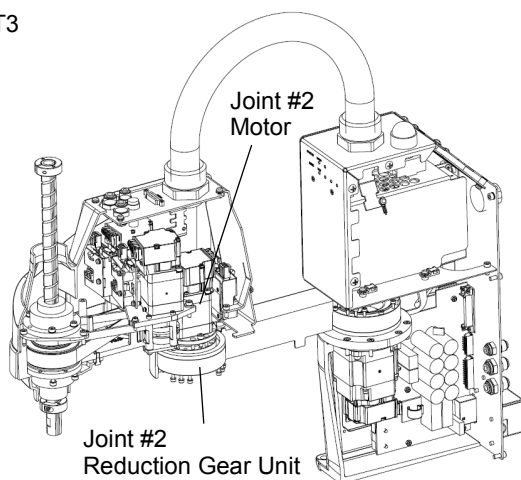

T6

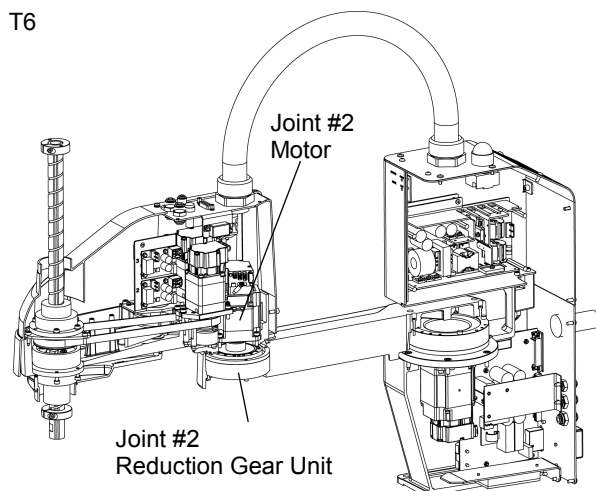

## 10.1 Replacing Joint #2 Motor

	Name		Quantity	Note
Maintenance Parts	Motor	100W(J2/J3)	1	T3: 2182562
		200W	1	T6: 2190963
	O-ring	Between reduction gear unit and Arm #2	1	T3: 1653819 T6: 1653181
Tools	Hexagonal wrench	width across flats: 2 mm	1	For M4 set screw
		width across flats: 3 mm	1	For M4 screw
	Cross-point screwdriver (No. 2)		1	For cross-recessed screw
	Torque wrench		1	
	Wiping cloth		1	For wiping grease
Grease	Grease	SK-2	-	For T3
		SK-1A	-	For T6



A brake is mounted on the Joint #3 motor to prevent the shaft from lowering down due to the weight of the end effector while the power to the Manipulator is OFF or while the motor is in OFF status (MOTOR OFF).

Move the shaft down to its lower limit before the replacement procedure following the removal steps.

### Joint #2 Motor Removal

- (1) Turn ON the Manipulator.
- (2) Push down the shaft to its lower limit while pressing the brake release switch. Be sure to keep enough space and prevent the end effector hitting any peripheral equipment.

The brake release switch affects only Joint #3. When the brake release switch is pressed, the Joint #3 brake is released.

Be careful of the shaft while the brake release switch is being pressed because the shaft may be lowered by the weight of an end effector.

- (3) Turn OFF the Manipulator.
- (4) Remove the Arm Top Cover.

For details, refer to *Maintenance: 7.1 Arm Top Cover*.

- (5) Remove the User Plate.

For details, refer to *Maintenance: 7.7 User Plate*.

- (6) Remove the Motor unit connector of Joint #2.

- A: Power cable connector (T3 only)
- B: Signal cable connector (IN/OUT ×1 for each)
- C: AMP cable connector (T6 only)

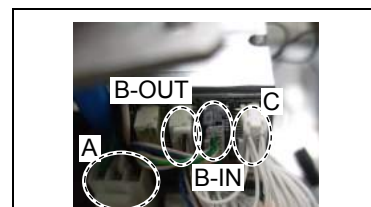

- T6: Remove the connector of the AMP board unit on the Joint # 2.

- D: Motor cable connector (T6 only)

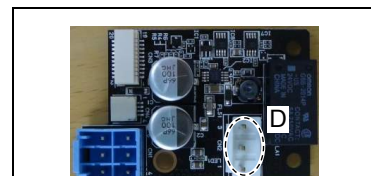

- (7) Unscrew the Motor unit mounting screws.

T3: Motor flange mounting screws 3-M4×10

T6: Motor mounting screws 4-M4×12

Remove the Joint #2 motor unit from the Arm #2.

To pull out the motor smoothly, move the Arm #2 slowly by hand while pulling the motor.

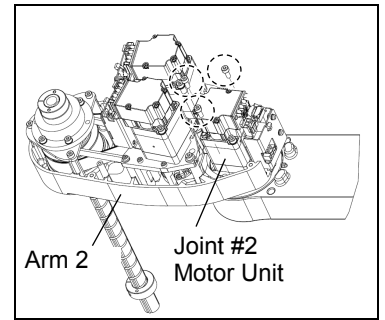

- (8) Remove the waveform generator from the Joint #2 motor.

2-M4×6 Set screw

M4 Brass Bushing

NOTE  There is a brass bushing in one of the set screw holes. Be sure to keep the bushing.

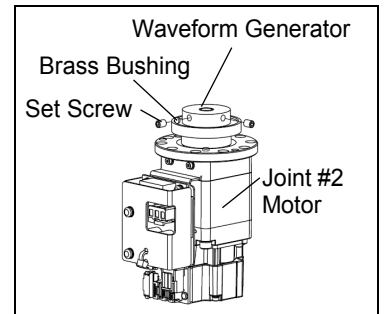

- (9) T3: Remove the motor flange from the Joint #2 motor.

2-M4×55+M4 Small washer

NOTE  Washer will be necessary again when mounting motor flange. Be sure to keep the washer.

T6: There is no motor flange.

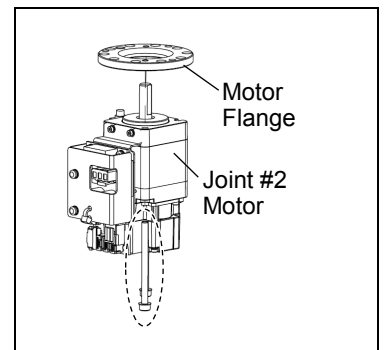

- (10) T6: Remove the motor ground wire

Hexagon socket head cap bolt with washer: 2-M2×5

NOTE  T3: There is no motor ground wire.

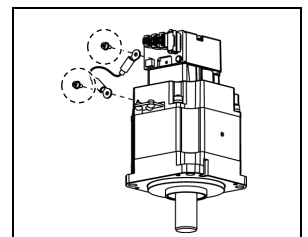

Joint #2 Motor Installation

(1) T6: Install the motor ground wire.

Hexagon socket head cap bolt with washer: 2-M2×5  
Tightening torque: 0.2 ± 0.05 N·

NOTE  T3: There is no motor ground wire.

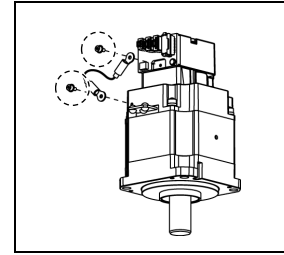

(2) T3: Mount the motor flange on the Joint #2 motor.

2-M4×55+M4 Small washer

NOTE  Be careful about position of flange and motor when mounting the flange.

NOTE  T6: There is no motor flange.

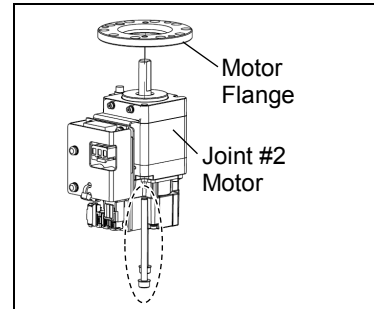

(3) Mount the waveform generator on the Joint #2 motor.

2-M4×6 Set screw  
M4 Brass Bushing

NOTE  Tighten one of the set screws vertically on the flat face of the motor shaft. Insert a bushing into the other set screw hole to prevent damage to the motor shaft.

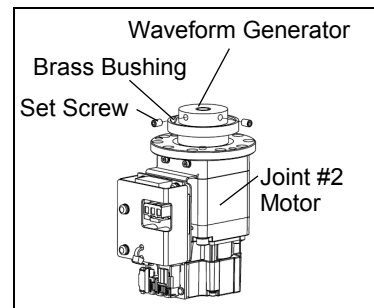

T3: Be sure to align the end face of the waveform generator to the end face of the motor shaft.

T6: Be sure to fix the end face of the waveform generator at the position that is 0.5 mm above the end face of the motor shaft.



■ See the figures above for the orientation of the waveform generator. Be sure to install the waveform generator properly. Improper installation of the waveform generator will result in improper function of the Manipulator.

(4) Apply grease between the waveform generator and motor flange.

Grease volume T3: SK-2 4 g  
T6: SK-1A 6 g

(5) Mount the Joint #2 motor unit on the Arm #2.

T3: Motor flange mounting screws 3-M4×10

T6: Motor mounting screws 4-M4×12

To insert the motor, slowly move the Arm #2 by hand and push in.

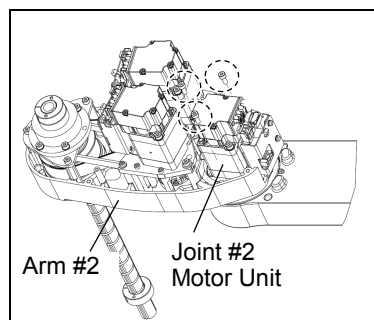

- (6) Mount a connector of Joint #2 motor unit.

A: Power cable connector (T3 only)  
 B: Signal cable connector (IN/OUT ×1 for each)  
 C: AMP cable connector (T6 only)

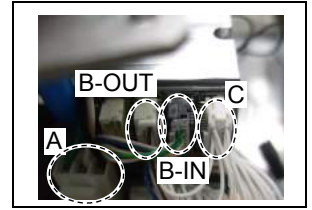

- T6: Install the AMP board connector of joint #2.

D: Motor Cable Connector (T6 only)

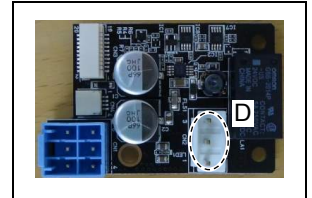

- (7) Mount the User Plate.

For details, refer to *Maintenance: 7.7 User Plate*.

- (8) Mount the Arm Top Cover.

For details, refer to *Maintenance: 7.1 Arm Top Cover*.

- (9) Turn ON the manipulator.

For details, refer to *Setup & Operation 6.5 LED*

**NOTE**  When starting the manipulator for the first time after replacing the motor unit, the motor unit firmware is automatically updated. DO NOT turn OFF the manipulator until it starts.

- (10) Execute the calibration for Joint #2.

For details refer to *Maintenance: 16. Calibration*.

## 10.2 Replacing Joint #2 Reduction Gear Unit

A reduction gear unit consists of the following three parts. When replacing the reduction gear unit, be sure to always replace the waveform generator, flexspline, and circular spline all together as one set.

Waveform generator, Flexspline, Circular spline

For details of the reduction gear unit, refer to *Maintenance 19. Maintenance parts list*

		Name	Quantity	Note
Maintenance parts	Reduction Gear Unit		1	T3: 1718304
				T6: 1750571
Tools	Hexagonal wrench	width across flats: 2 mm	1	For M4 set screw
		width across flats: 2.5 mm	1	For M3 screw
		width across flats: 3 mm	1	For M4 screw
	Torque wrench		1	
	Cross-point screwdriver (No. 2)		1	For cross-recessed screw
	Spatula		1	For apply grease
	Wiping cloth		1	For wiping grease (Flange)
1			For wiping grease (Bolt)	
Material	Screw (M3: Length about 20 mm)		2	For removing the flexspline
	Wire tie		-	
Grease	Grease	SK-2	-	For T3
		SK-1A	-	For T6

**NOTE** A brake is mounted on the Joint #3 motor to prevent the shaft from lowering down due to the weight of the end effector while the power to the Manipulator is OFF or while the motor is in OFF status (MOTOR OFF).

Move the shaft down to its lower limit before the replacement procedure following the removal steps.

### Joint #2 Reduction Gear Unit Removal

- (1) Remove the waveform generator from the Joint #2 motor.

For details, refer to *Maintenance:*

*10.1 Replacing Joint #2 Motor "Removal Procedure".*

- (2) Remove the Arm #2 by removing the screws mounting the Arm #2 on the reduction gear unit

T3: A: 10-M3×18  
 B: 8-M3×30+M3 small washer  
 C: 4-M3×15+M3 small washer

T6: A: 16-M3×28  
 B: 8-M3×32+8-M3 small washer  
 C: 4-M3×12+4-M3 small washer

Remove the Arm #2

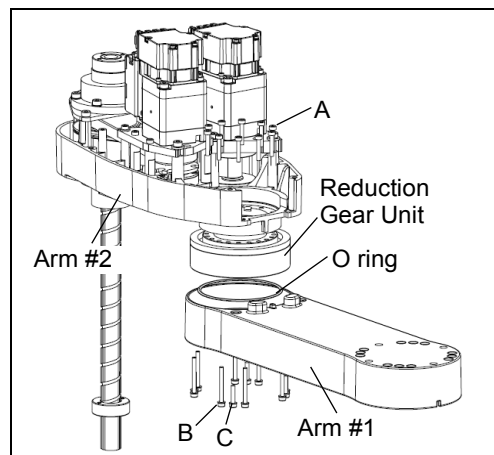

- (3) Remove the reduction gear unit from the Arm #1 by removing the screws that mounts the reduction gear unit on the Arm #1.

There is an O-ring between the Arm #1 and the reduction gear unit. Be sure to keep the O-ring.

Joint #2  
Reduction  
Gear Unit  
Installation

- (1) A new reduction gear unit contains the parts shown in the picture on the right when it is unpacked.

The gear grooves of the flexspline, circular spline, and the bearings of the waveform generator have been greased. Wipe off excess grease from the mounting surface.

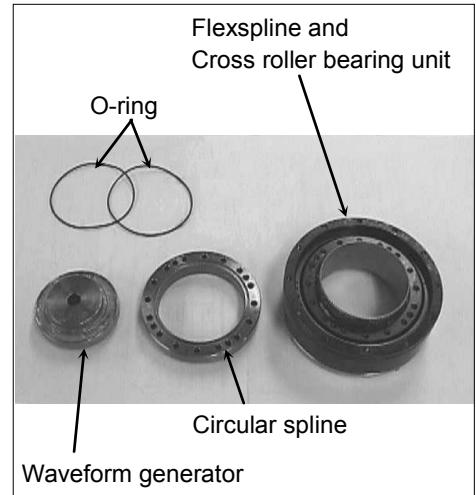

- Never adjust (loosen or tighten) the mounting bolts between the flexspline and cross roller bearing unit. If the mounting bolts are adjusted, the flexspline and cross roller bearing unit must be aligned by the maker of the reduction gear unit.

- (2) Fit the O-rings into the grooves on both sides of the new circular spline.

Make sure that the rings do not come out of the grooves.

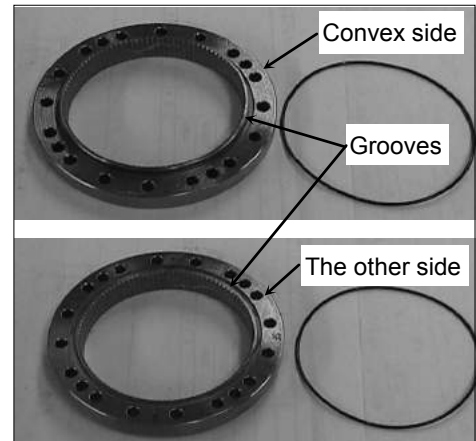

- (3) Face the convex side of the circular spline down, and then fit it into the flexspline.



- (4) Match the screw holes on the inner ring of the cross roller bearing unit and the through holes of the circular spline.



- (5) Set the O-ring removed in the removal step (6) into the O-ring (between the Arm #1 and the reduction gear unit) groove of the Arm #1 and install the flexspline on the Arm #1.

T3: A: 10-M3×18  
 B: 8-M3×30+M3 small washer  
 C: 4-M3×15+M3 small washer

T6: A: 16-M3×28  
 B: 8-M3×32+8-M3 small washer  
 C: 4-M3×12+4-M3 small washer

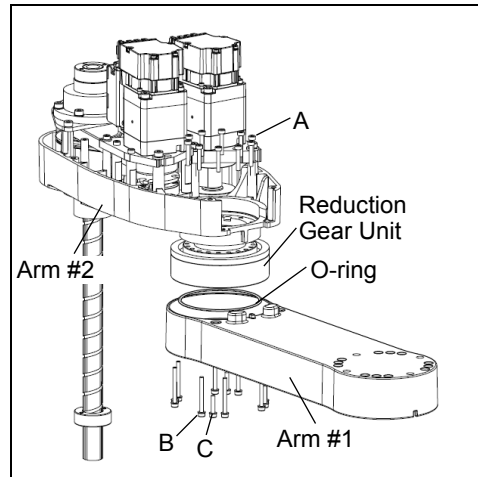

Loosely secure all bolts in a crisscross pattern so that the bolts will be secured evenly. Then, using a torque wrench, tighten each bolt securely in a crisscross pattern at the torque specified in the table below.

Item	Bolt type	Tightening torque
Joint #2 reduction gear unit	M3	2.4±0.1N·m

NOTE  

Be careful not to apply too much force since it may damage the parts

- (6) Apply grease between the motor flange and waveform generator and next inside the flexspline.

Between the motor flange and waveform generator

Grease volume T3: SK-2 4 g  
 T6: SK-1A 6 g

Inside the flexspline

Grease volume T3: SK-2 11 g  
 T6: SK-1A 16 g

- (7) Set the attached O-ring into the O-ring groove of the circular spline.

Secure the Arm #2 on the circular spline.

- (8) Mount and Joint #2 motor.

For details, refer to *Maintenance*:

10.1 Replacing Joint #2 Motor “Installation procedure”.



## 11. Joint #3



- Do not connect or disconnect the motor connectors while the power to the robot system is turned ON. Connecting or disconnecting the motor connectors with the power ON is extremely hazardous and may result in serious bodily injury as the Manipulator may move abnormally, and also may result in electric shock and/or malfunction of the robot system.
- To shut off power to the robot system, disconnect the power plug from the power source. Be sure to connect the AC power cable to a power receptacle. DO NOT connect it directly to a factory power source.
- Before performing any replacement procedure, turn OFF the Controller and related equipment, and then disconnect the power plug from the power source. Performing any replacement procedure with the power ON is extremely hazardous and may result in electric shock and/or malfunction of the robot system.



- Be careful not to apply excessive shock to the motor shaft when replacing the motors. The shock may shorten the life cycle of the motors and encoder and/or damage them.
- Never disassemble the motor and encoder. A disassembled motor and encoder will cause a positional gap and cannot be used again.

After parts have been replaced (motors, reduction gear units, brakes, timing belts, ball screw spline unit, etc.), the Manipulator cannot operate properly because a mismatch exists between the origin stored in each motor and its corresponding origin stored in the Robot system.

Because of that, it is necessary to perform calibration (encoder rest and calibration) to match these origins.

Refer to *Maintenance: 16. Calibration* to execute the calibration.

T3

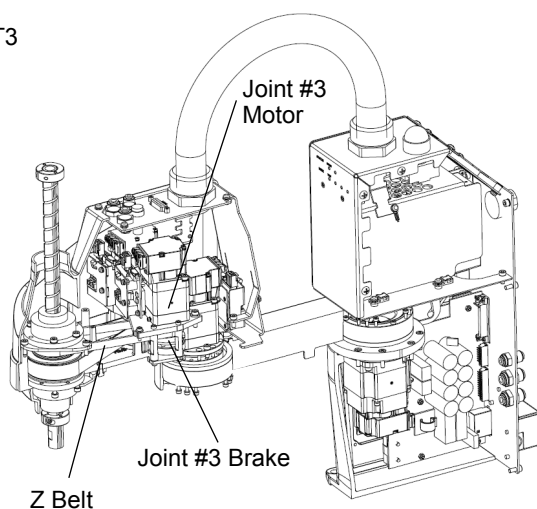

T6

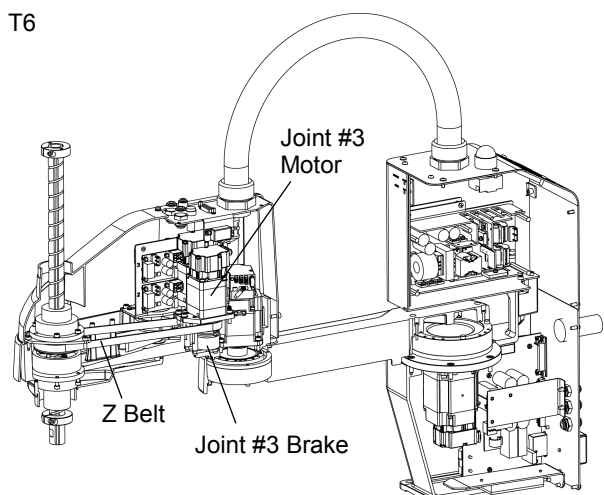

**11.1 Replacing Joint #3 Motor**

	Name	Quantity	Note	
Maintenance parts	Motor	100W(J2/J3)	1	T3: 2182562
		100W	1	T6: 2182601
Tools	Hexagonal wrench	width across flats: 1.5 mm	1	For M3 set screw
		width across flats: 2.5 mm	1	For M5 set screw
		width across flats: 3 mm	1	For M4 screw
	Torque wrench		1	
	Cross-point screwdriver (No. 2)		1	For cross-recessed screw
	Nippers		1	For cutting wire tie
	Force gauge		1	Z: Belt tension 69 N (7.0 ± 0.5 kgf·cm)
	Suitable cord (Length about 800 mm)		1	For belt tension
Material	Wire tie	-		

**NOTE**  A brake is mounted on the Joint #3 motor to prevent the shaft from lowering down due to the weight of the end effector while the power to the Manipulator is OFF or while the motor is in OFF status (MOTOR OFF)

Move the shaft down to its lower limit before the replacement procedure following the removal steps.

**Joint #3 motor Removal**

- (1) Turn ON the Manipulator.
- (2) Push down the shaft to its lower limit while pressing the brake release switch. Be sure to keep enough space and prevent the end effector hitting any peripheral equipment.

The brake release switch affects only Joint #3. When the brake release switch is pressed, the Joint #3 brake is released.

Be careful of the shaft while the brake release switch is being pressed because the shaft may be lowered by the weight of an end effector.

- (3) Turn OFF the Manipulator.
- (4) Remove the Arm Top Cover.

For details, refer to *Maintenance: 7.1 Arm Top Cover*.

- (5) Cut off the wire tie binding the cables.

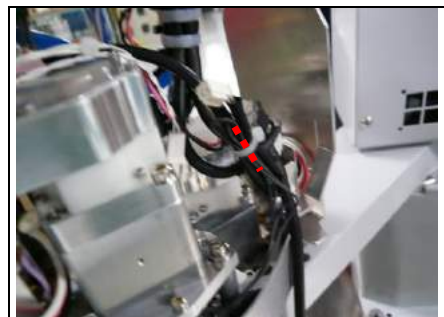

- (6) Remove the User Plate.

For details, refer to *Maintenance: 7.7 User Plate*.

(7) T6:

Remove the AMP board.

Sems bolt: 2-M3×6

Remove the all connectors of the amplifier unit. Remove the following connectors from the AMP board.

A: Power cable connector (3 connectors)

B: AMP cable connector (3 connectors)

C: Motor cable connector (3 connectors)

D: Brake cable connector (1 connector)

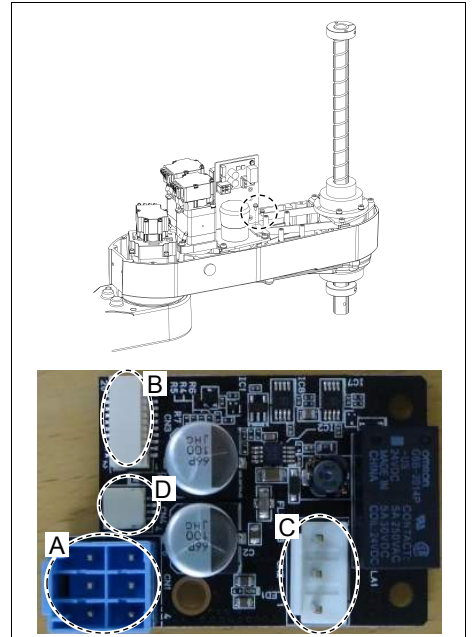

(8) Remove the Joint #3 motor unit connectors.

A: Power cable connector (T3 only)

B: Signal cable connector  
(IN/OUT×1 for each)

C: Brake cable connector (T3 only)

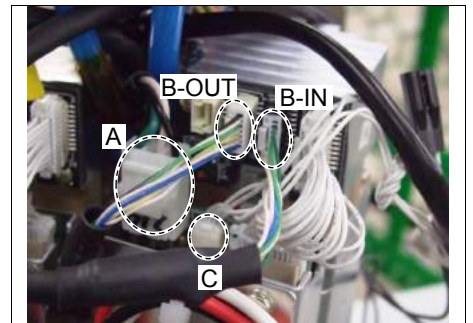

(9) Unscrew the Joint #3 motor unit mounting bolts and remove the washer.

T3: a: 2-M4×15+M4 Slotted hole washer

b: M3×12+M3 Slotted hole washer

T6: ab: 3-M4×15+M4 Washer



The washer will be necessary again when mounting Z belt. Be sure to keep the slotted hole washer.

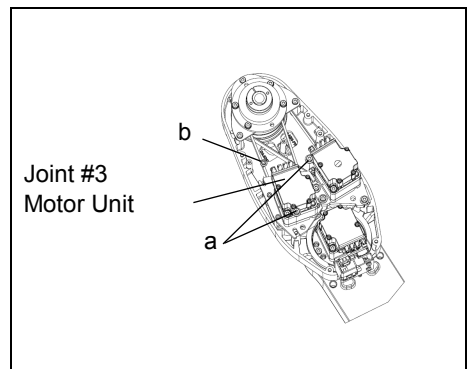

(10) T3: Unscrew the Joint #3 motor brake mounting bolts.

3-M3×12

Remove the Joint #3 motor unit and solenoid brake.



Pulley carries the belt. Tilts Joint #3 motor little and pull it up with avoiding the belt. Then remove the motor.

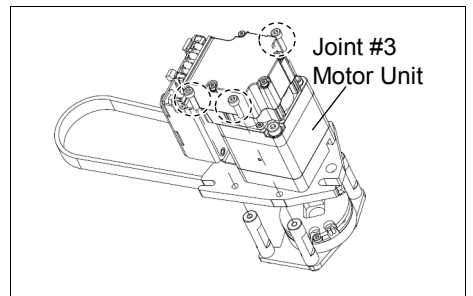

- (11) Remove the Motor plate from the Joint #3 motor.

2-M4×55+M4 Small washer

Washer will be necessary again when mounting the Motor plate. Be sure to keep the washer.

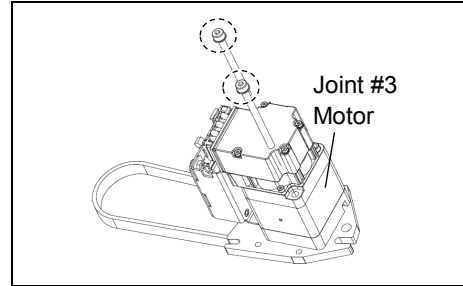

- (12) Loosen the screws of the pulley and brake hub and remove them from the Joint #3 motor.

a: M5×8 Set screw

b: M5×8 Set screw +M5 Busing

c: T3: M3×3 Set screw

T6: M3×4 Set screw

d: T3: M3×3 Set screw +M3 Busing

T6: M3×4 Set screw +M3 Busing

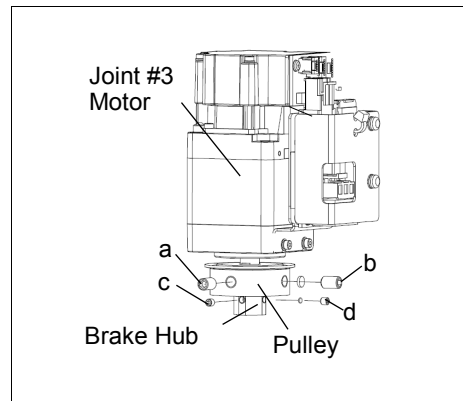

There is a brass bushing in one of the set screw holes. Be sure to keep the bushing.

- (13) T6: Remove the motor ground wire.

Hexagon socket head cap bolt with washer: 2-M2×5

NOTE  

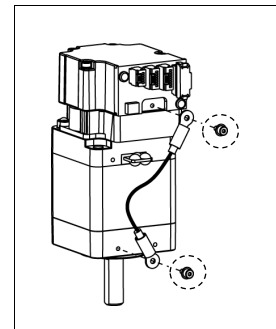

T3: There is no motor ground wire.



Joint #3 motor Installation (1) T6: Connect the motor ground wire to the motor.

Hexagon socket head cap bolt with washer: 2-M2×5

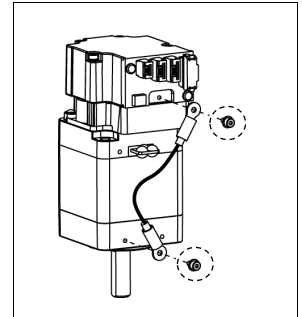
Tightening torque:  $0.2 \pm 0.05 \text{ N}\cdot\text{m}$



NOTE



T3: There is no motor ground wire

(2) Mount the pulley and brake hub to the Joint #3 motor.

a: M5×8 Set screw

b: M5×8 Set screw +M5 Busing

c: T3: M3×3 Set screw

T6: M3×4 Set screw

d: T3: M3×3 Set screw +M3 Busing

T6: M3×4 Set screw +M3 Busing

T3: Fix the pulley leaving 5.5 mm space from the motor.

Make sure to leave 5.5 mm between the motor and the pulley.

T6: Fix the pulley leaving 0.5 mm space from the motor plate.

Make sure to leave 0.5 mm between the motor plate and the pulley when mounting the motor plate.

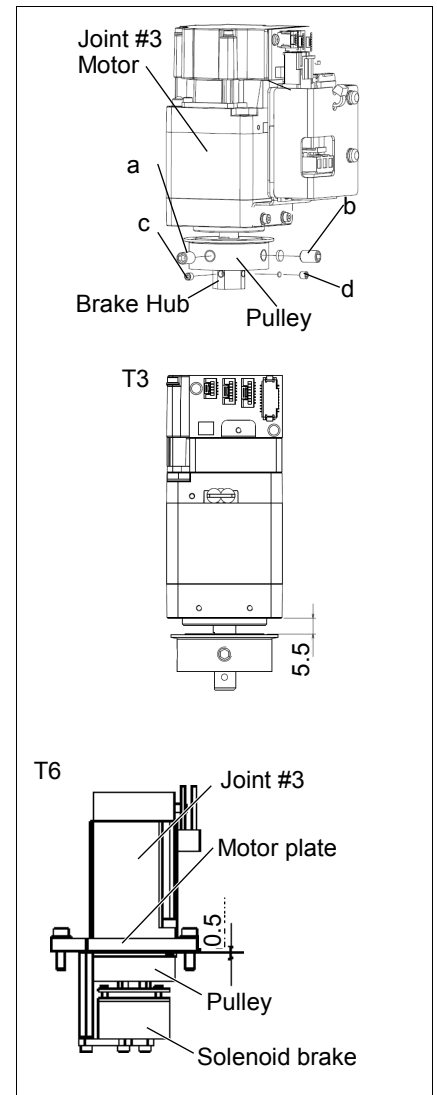

NOTE



Tighten one of the set screws vertically on the flat face of the motor shaft.

Insert a bushing into the other set screw hole to prevent damage to the motor shaft.

(3) Mount the Joint #3 motor on the Motor plate.

2-M4×55+M4 Small washer

NOTE



Be careful about the position of Motor plate and motor when mounting Motor plate.

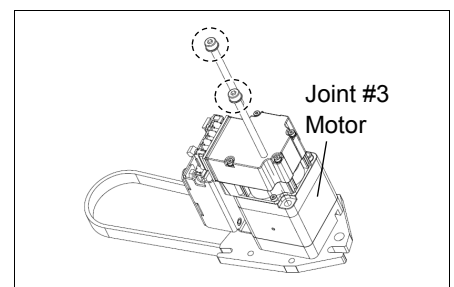

- (4) T3: Pass the pulley through the Z belt and fit the brake disk to the hub.



When passing the belt, make sure that the belt does not out of the pulley.

Mount the Joint #3 motor brake.

3-M3×12

Secure the motor cables facing to front of the Arm.

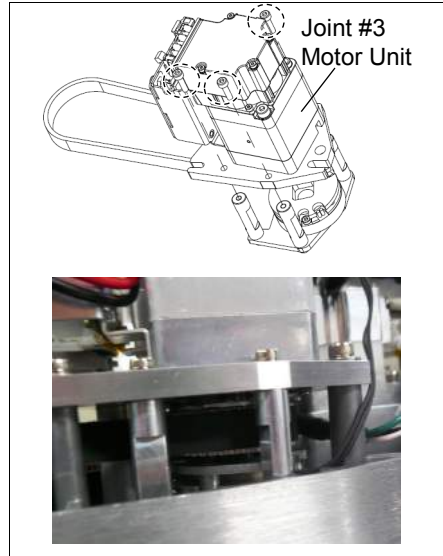

- (5) Loosely secure the Joint #3 motor unit to Arm #2.



Check that the motor unit can be moved by hand, and it will not tilt when pulled. If the unit is secured too loose or too tight, the belt will not have the proper tension.

- (6) Apply the proper tension to the Z belt, and secure the Joint #3 motor unit.

T3: a: 2-M4×15+M4 slotted hole washer  
 b: M3×12+M3 slotted hole washer

T6: ab: 3-M4×15+M4 washer

Pass a suitable cord or string around the plate hole of the Joint #3 motor unit. Then, pull the cord using a force gauge or similar tool to apply the specified tension shown in the figure on the right.

Z belt tension:  
 34.5 N (3.5 ± 0.5 kgf)

Axial force (When pulling):  
 69 N (7.0 ± 0.5 kgf)

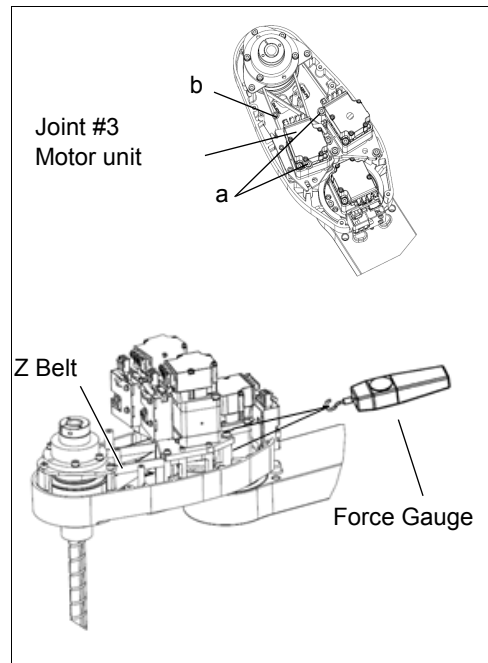

To check belt tension with the tension meter, refer to the following.  
*Maintenance: 11.4 Checking the Timing Belt Tension (Z Belt).*

- (7) Connect the Joint #3 motor unit connectors.

- A: Power cable connector (T3 only)
- B: Signal cable connector (IN/OUT)
- C: Brake cable connector (T3 only)

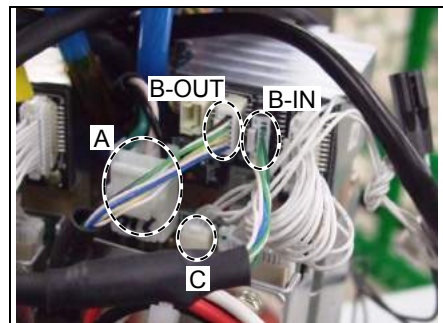

- (8) T6: Install the AMP board.

Sems bolt: 2-M3×6

Connect all connectors to the AMP board.

A: Power cable connector (3 connectors)

B: AMP cable connector (3 connectors)

C: Motor cable connector (3 connectors)

D: Brake cable connector (1 connector)

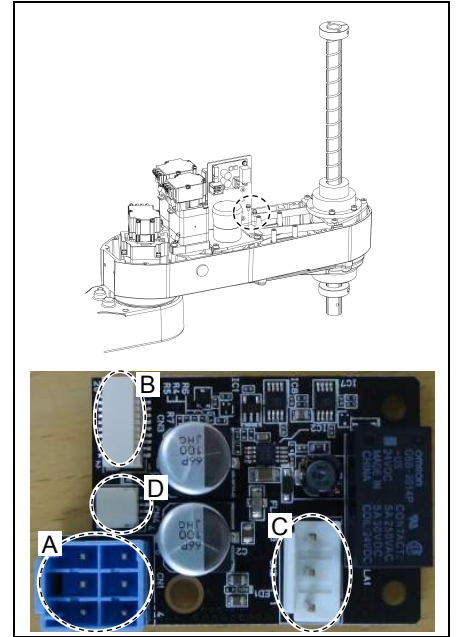

- (9) Mount the User Plate.

For details, refer to *Maintenance: 7.7 User Plate*.

- (10) Bind the brake cables with a wire tie in their original positions as before removed in the removal step (5).

- (11) Mount the Arm Top Cover.

For details, refer to *Maintenance: 7.1 Arm Top Cover*.

- (12) Turn ON the manipulator.

For details, refer to *Setup & Operation 6.5 LED*

**NOTE**  When starting the manipulator for the first time after replacing the motor unit, the motor unit firmware is automatically updated. DO NOT turn OFF the manipulator until the it starts.

- (13) Execute the calibration of Joints #3, #4.

For details, refer to *Maintenance: 16. Calibration*

## 11.2 Replacing the Timing Belt

	Name	Quantity	Note	
Maintenance part	Z belt	width: 9 mm	1	T3: 1554773
		width: 10 mm	1	T6: 1563316
Tools	Hexagonal wrench	width across flats: 2.5 mm	1	For M3 screw
		width across flats: 3 mm	1	For M4 screw
	Torque wrench		1	
	Cross-point screwdriver (No. 2)		1	For cross-recessed screw
	Force gauge		1	Z: Belt tension 69 N (7.0 ± 0.5 kgf)
	Suitable cord (Length about 800 mm)		1	For belt tension
Material	Wire tie	-		

**NOTE** A brake is mounted on the Joint #3 motor to prevent the shaft from lowering down due to the weight of the end effector while the power to the Manipulator is OFF or while the motor is in OFF status (MOTOR OFF).

Move the shaft down to its lower limit before the replacement procedure following the removal steps.

### Z belt Removal

- (1) Remove the Joint #3 motor unit.

For details, refer to *Maintenance*:

*11.1 Replacing Joint #3 Motor "Removal Procedure"*.

- (2) Remove the screws for the spline plate.

3-M4×12

Holding the spline plate upward, pull out the Z belt.

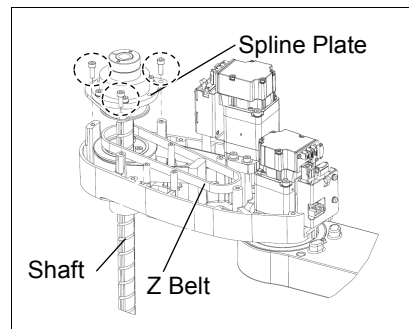

### Z belt Installation

- (1) Pass a new Z belt through the shaft.
- (2) Lower the spline plate with the Z belt placed around the spline plate pulley.

Secure the spline plate with 3 screws.

Loosely secure the spline plate on the Arm #2 and move the shaft up and down several times before firmly secure the spline plate.

- (3) Mount Joint #3 motor unit.

For details, refer to *Maintenance*:

*11.1 Replacing Joint #3 Motor "Installation Procedure"*.



## 11.3 Replacing the Brake

	Name	Quantity	Note	
Maintenance part	Solenoid brake unit	1	T3: 2182694	
		1	T6: 1750573	
Tools	Hexagonal wrench	width across flats: 2 mm	1	For M2.5 set screw
		width across flats: 2.5 mm	1	For M3 screw
		width across flats: 3 mm	1	For M4 screw
		width across flats: 4 mm	1	For M5 screw
	Torque wrench	1		
	Cross-point screwdriver (No. 2)	1	For cross-recessed screw	
	Force gauge	1	Z: Belt tension 69 N (7.0 ± 0.5 kgf)	
	Suitable cord (Length about 800 mm)	1	For belt tension	
Material	Wire tie	-		



A brake is mounted on the Joint #3 motor to prevent the shaft from lowering down due to the weight of the end effector while the power to the Manipulator is OFF or while the motor is in OFF status (MOTOR OFF).

Move the shaft down to its lower limit before the replacement procedure following the removal steps.

### Joint #3 brake Removal

- (1) Remove the Joint #3 motor unit.

For details, refer to *Maintenance*:

*11.1 Replacing Joint #3 Motor "Removal Procedure"*.

- (2) T3: Remove the brake from the brake support.

3-M2.5×12

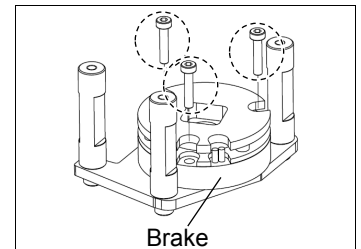

- T6: Remove the brake from the motor plate and the brake plate.

4-M3×8

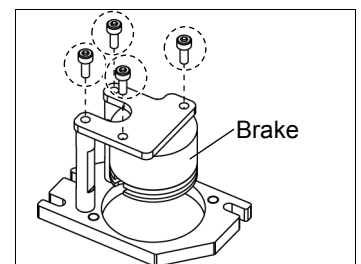

### Joint #3 brake Installation

- (1) T3: Mount the brake support on the brake.

3-M2.5×12

- T6: Mount the brake on the motor plate and the brake plate.

4-M3×8

- (2) Mount Joint #3 motor unit and solenoid brake.

For details, refer to *Maintenance*:

*11.1 Replacing Joint #3 Motor "Installation Procedure"*.

### 11.4 Checking the Timing Belt Tension (Z Belt)

	Name	Quantity	Note
Tool	Sonic tension meter	1	For details of usage and measurement methods of the tension meter, refer to the instruction manual of the tension meter.

Joint #3

Belt tension check

- (1) Enter appropriate setting values to the sonic tension meter.

Model	Belt	Unit mass M [g/ (1 mm width ×1 m length)]	Width W [mm]	Span S [mm]
T3	Z belt	1.9	9	127
T6	Z belt	1.9	10	212

- (2) Strum the belt and measure tension.

NOTE



Measurement failure may occur if the microphone touches the belt during measurement.

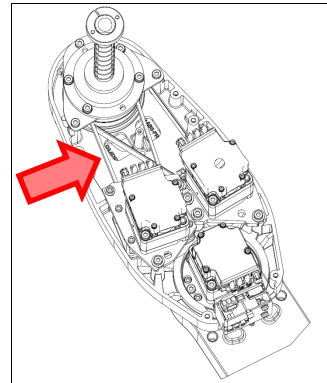

## 12. Joint #4



- Do not connect or disconnect the motor connectors while the power to the robot system is turned ON. Connecting or disconnecting the motor connectors with the power ON is extremely hazardous and may result in serious bodily injury as the Manipulator may move abnormally, and also may result in electric shock and/or malfunction of the robot system.
- To shut off power to the robot system, disconnect the power plug from the power source. Be sure to connect the AC power cable to a power receptacle. DO NOT connect it directly to a factory power source.
- Before performing any replacement procedure, turn OFF the Controller and related equipment, and then disconnect the power plug from the power source. Performing any replacement procedure with the power ON is extremely hazardous and may result in electric shock and/or malfunction of the robot system.



- Be careful not to apply excessive shock to the motor shaft when replacing the motors. The shock may shorten the life cycle of the motors and encoder and/or damage them.
- Do not mount Joint #4 motor unit on the other joints since specification is different from that of Joint #2 or #3 motor units. Marking is applied on the motor case of Joint #4 motor unit.
- Never disassemble the motor and encoder. A disassembled motor and encoder will cause a positional gap and cannot be used again.

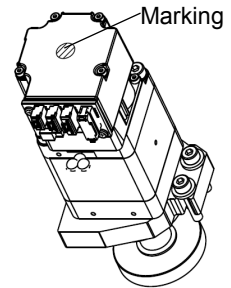

After parts have been replaced (motors, reduction gear units, a brake, timing belts, ball screw spline unit, etc.), the Manipulator cannot operate properly because a mismatch exists between the origin stored in each motor and its corresponding origin stored in the Robot system. Because of that, it is necessary to perform calibration (encoder rest and calibration) to match these origins.

Refer to *Maintenance: 16. Calibration* to execute the calibration.

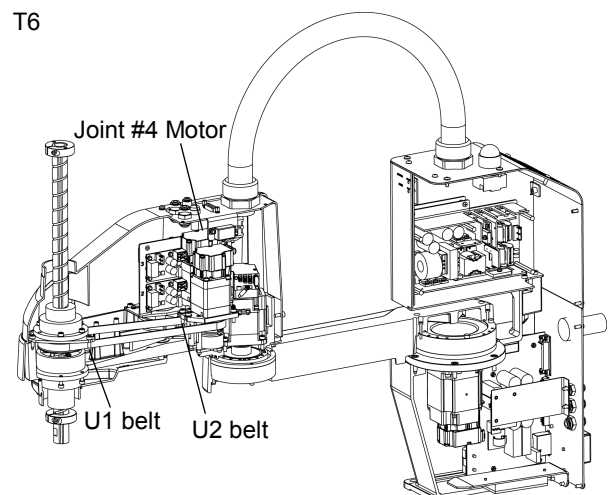
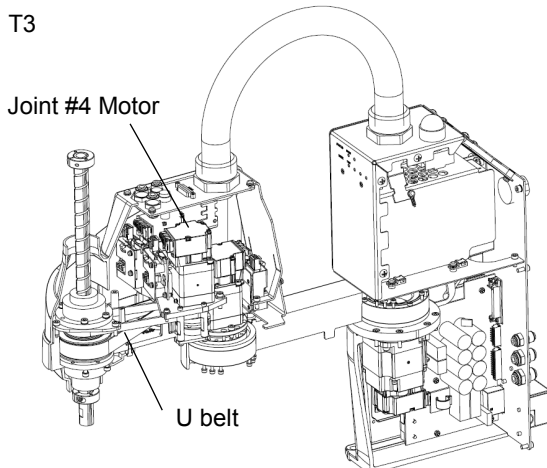

## 12.1 Replacing Joint #4 Motor

	Name	Quantity	Note	
Maintenance part	Motor	100W(J4)	1	T3: 2182669
			1	T6: 2182670
Tools	Hexagonal wrench	width across flats: 2 mm	1	For M4 set screw
		width across flats: 3 mm	1	For M4 screw
	Torque wrench		1	
	Cross-point screwdriver (No. 2)		1	For cross-recessed screw
	Force gauge		1	U: Belt tension 69N (7.0 ± 0.5 kgf)
	Suitable cord (Length about 800 mm)		1	For belt tension

 CAUTION	<p>■ The belt must be installed with proper tension; otherwise the following problems may occur.</p> <p style="padding-left: 20px;">If falling below the lower limit : Jumping of the belt gears (position gap)</p> <p style="padding-left: 20px;">If exceeding the upper limit : Abnormal noise or vibration (oscillation), decline in the life of driving parts</p>
--	---

**NOTE**  

A brake is mounted on the Joint #3 motor to prevent the shaft from lowering down due to the weight of the end effector while the power to the Manipulator is OFF or while the motor is in OFF status (MOTOR OFF).

Move the shaft down to its lower limit before the replacement procedure following the removal steps.

**Joint #4 motor Removal**

- (1) Turn ON the Manipulator.
- (2) Push down the shaft to its lower limit while pressing the brake release switch. Be sure to keep enough space and prevent the end effector hitting any peripheral equipment.
 

The brake release switch affects only Joint #3. When the brake release switch is pressed, the Joint #3 brake is released.

Be careful of the shaft while the brake release switch is being pressed because the shaft may be lowered by the weight of an end effector.
- (3) Turn OFF the Manipulator.
- (4) Remove the Arm Top Cover.
 

For details, refer to *Maintenance: 7.1 Arm Top Cover*.
- (5) Remove the User Plate.
 

For details, refer to *Maintenance: 7.7 User Plate*.

- (6) T6: Remove the AMP board.

Sems bolt: 2-M3×6

Remove the following connectors from the AMP board.

- A: Power cable connector (3 connectors)
- B: AMP cable connector (3 connectors)
- C: Motor cable connector (3 connectors)
- D: Brake cable connector (1 connector)

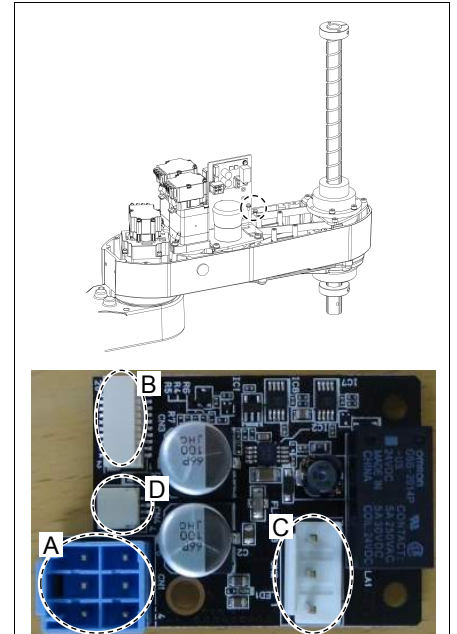

- (7) Remove the Joint 4 motor unit connectors.

- A: Power cable connector (T3 only)
- B: Signal cable connector (IN only)

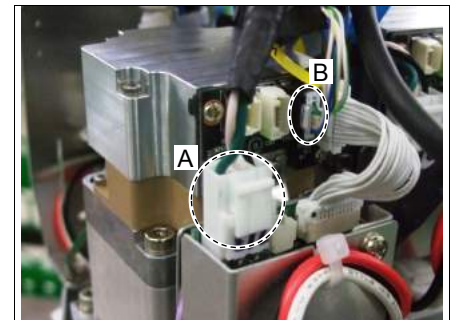

- (8) Remove the Joint #4 motor unit from the Arm #2.

Remove the bolts securing the Joint #4 motor on the motor plate and pull out the motor.

T3: 3-M4x20+M4 slotted hole washer

T6: 3-M4x20+M4 washer

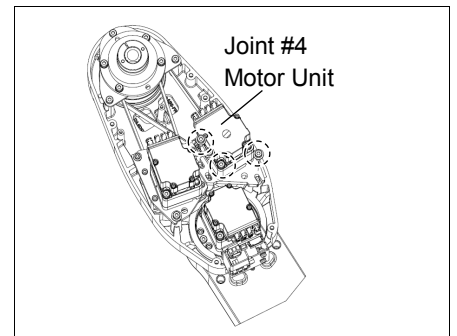

Pulley carries the belt. Tilts Joint #4 motor little and pull it up with avoiding the belt when removing the motor. Washer will be necessary again when mounting the U belt. Be sure to keep the washer.

- (9) Remove the pulley and bearing from the Joint 4 motor.

M4×8 set screw

M4×8 set screw +M4 busing

There is a brass bushing in one of the set screw holes. Be sure to keep the bushing.

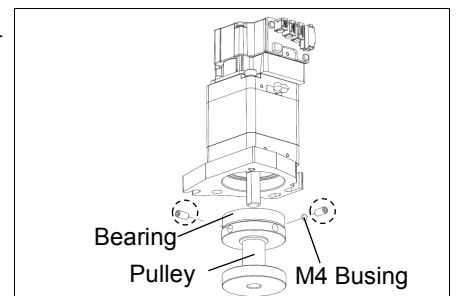

(10) Remove the motor plate from the Joint #4 motor.

2-M4×55 +M4 small washer

Washer will be necessary again when mounting the motor plate. Be sure to keep the washer.

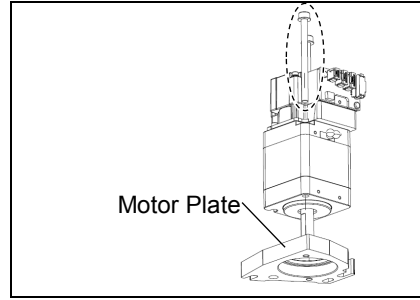

(11) T6: Remove the motor ground wire.

Hexagon socket head cap bolt with washer: 2-M2×5

NOTE  

T3: There is no motor ground wire.

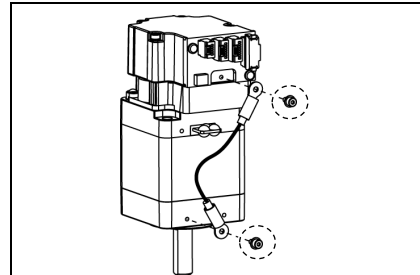

Joint #4 motor Installation (1) T6: Connect the motor ground wire to the motor.

Hexagon socket head cap bolt with washer: 2-M2×5

Tightening torque:  $0.2 \pm 0.05 \text{ N}\cdot\text{m}$

T3: There is no motor ground wire

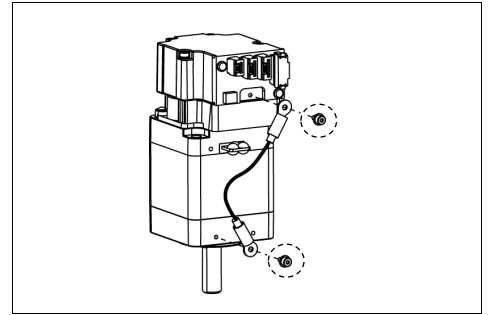

(2) Loosely secure the Joint #4 motor unit to Motor Plate.

2-M4×55 +M4 small washer

NOTE Be careful about position of the motor plate and motor.



Check that the motor unit can be moved by hand, and it will not tilt when pulled.

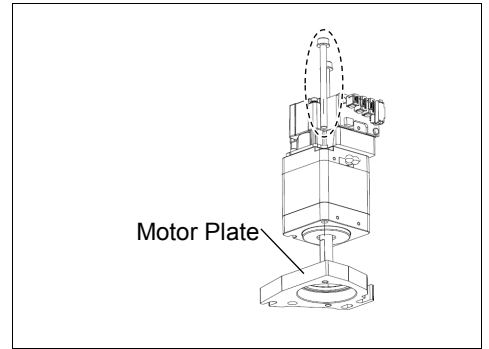

(3) Mount the pulley and bearing to the Joint #4 motor.

M4×8 Set screw

M4×8 Set screw+M4 busing

Tighten one of the set screws vertically on the flat face of the motor shaft.

Insert a bushing into the other set screw hole to prevent damage to the motor shaft. Then, tighten both set screws.

NOTE Make sure that the bearing is inserted completely when mounting the pulley. If the end faces of the motor plate and bearing fit, bearing is inserted completely.



Also, give a pressure to bearing when tightening.

pressure:  $2.9 \pm 0.1 \text{ kg}$

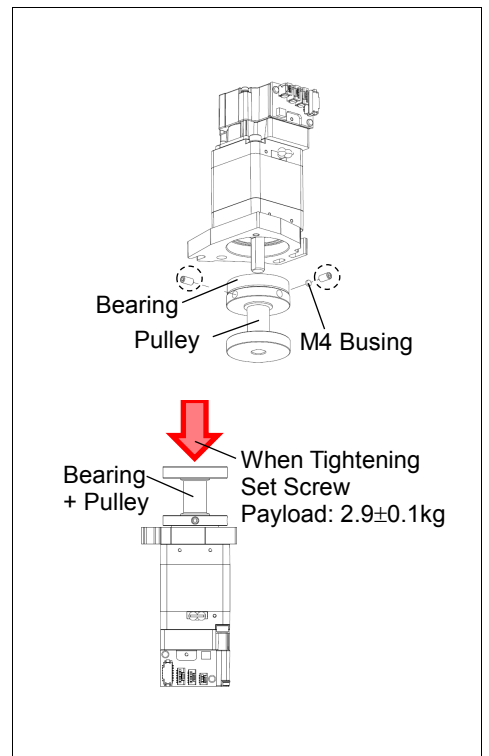

(4) Secure the motor plate on the Joint #4 motor.

(5) Place the pulley around the U belt and loosely secure to Arm #2.

NOTE



Make sure the motor unit can be moved by hand, and it will not tilt when pulled. If the unit is secured too loose or too tight, the belt will not have the proper tension. Make sure the gear grooves of the belt are fit into those of the pulleys completely.

- (6) Apply the proper tension to the U belt and secure the Joint #4 motor unit.

T3: 3-M4x20+M4 slotted hole washer

T6: 3-M4x20+M4 washer

Pass a suitable cord or string around the plate hole of the Joint #4 motor unit near its mounting plate.

Then, pull the cord using a force gauge or similar tool to apply the specified tension shown in the figure.

U belt tension:

T3: 34.5 N (3.5 ± 0.5 kgf)

T6: 29.0 N (3.0 ± 0.5 kgf)

Axial force (When pulling):

T3: 34.5 N (3.5 ± 0.5 kgf)

T6: 58.0 N (5.9 ± 0.5 kgf)

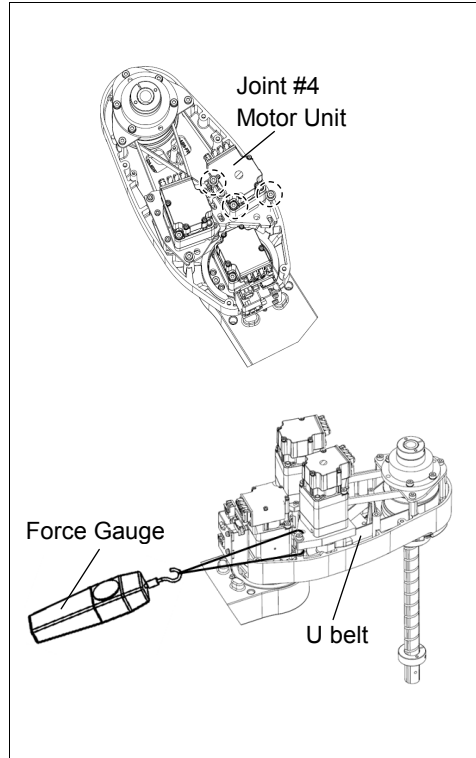

**NOTE**  To check belt tension with the tension meter, refer to the following.

*Maintenance: 12.3 Checking the Timing Belt Tension (U Belt).*

- (7) Connect the Joint #4 motor unit connectors.

A: Power cable connector (T3 only)

B: Signal cable connector

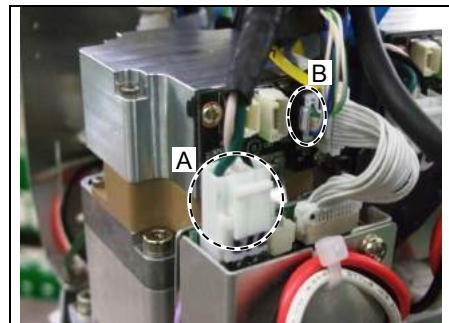

- (8) T6: Mount the AMP board.

Sems bolt: 2-M3x6

Connect the following connectors to the AMP board.

A: Power cable connector (3 connectors)

B: AMP cable connector (3 connectors)

C: Motor cable connector (3 connectors)

D: Brake cable connector (1 connector)

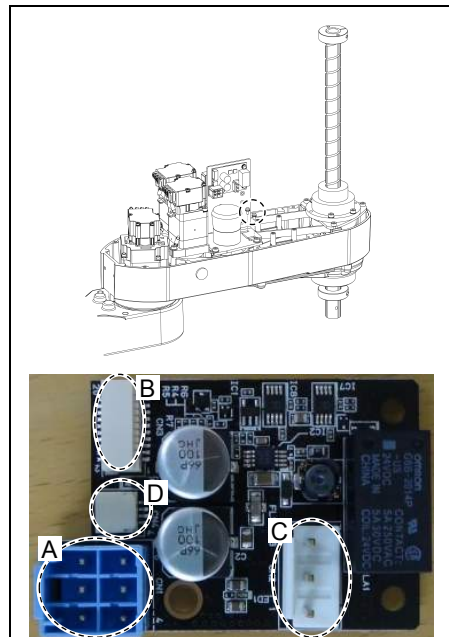



- (9) Mount the User Plate.

For details, refer to *Maintenance: 7.7 User Plate*.

- (10) Mount the Arm Top Cover.

For details, refer to *Maintenance: 7.1 Arm Top Cover*.

- (11) Execute the calibration of Joint #3 and #4.

For details on the calibration method, refer to *Maintenance: 16. Calibration*.

## 12.2 Replacing the Timing Belt

	Name		Quantity	Note
Maintenance part	U belt	width 17 mm	1	T3: 1709608
	U1 belt	width 10 mm	1	T6: 1674797
	U2 belt	width 15 mm	1	T6: 1674798
Tools	Hexagonal wrench	width across flats: 2.5 mm	1	For M3 screw
		width across flats: 3 mm	1	For M4 screw
	Torque wrench		1	
	Cross-point screwdriver (No. 2)		1	For cross-recessed screw
	Force gauge		1	Tension U: 69N (7.0 ± 0.5 kgf) U1: 58 N (5.9 ± 0.5 kgf) U2: 102 N (10.4 ± 0.75 kgf)
	Suitable cord (Length about 800 mm)		1	For belt tension

 <b>CAUTION</b>	<p>■ The belt must be installed with proper tension; otherwise the following problems may occur.</p> <p>If falling below the lower limit : Jumping of the belt gears (position gap)</p> <p>If exceeding the upper limit : Abnormal noise or vibration (oscillation), decline in the life of driving parts</p>
---	---

**NOTE**



A brake is mounted on the Joint #3 motor to prevent the shaft from lowering down due to the weight of the end effector while the power to the Manipulator is OFF or while the motor is in OFF status (MOTOR OFF).

Move the shaft down to its lower limit before the replacement procedure following the removal steps.

### 12.2.1 U2 Belt (T6)

#### U2 belt Removal

- (1) Turn ON the Manipulator.
- (2) Push down the shaft to its lower limit while pressing the brake release switch. Be sure to keep enough space and prevent the end effector hitting any peripheral equipment.

The brake release switch affects only Joint #3. When the brake release switch is pressed, the Joint #3 brake is released.

Be careful of the shaft while the brake release switch is being pressed because the shaft may be lowered by the weight of an end effector.

- (3) Turn OFF the Manipulator.
- (4) Remove the Arm Top Cover.

For details, refer to *Maintenance: 7.1 Arm Top Cover*.

- (5) Remove the User Plate.

For details, refer to *Maintenance: 7.7 User Plate*.

- (6) Remove the AMP board.

Sems bolt: 2-M3×6

Remove the following connectors from the AMP board.

- A: Power cable connector (3 connectors)
- B: AMP cable connector (3 connectors)
- C: Motor cable connector (3 connectors)
- D: Brake cable connector (1 connector)

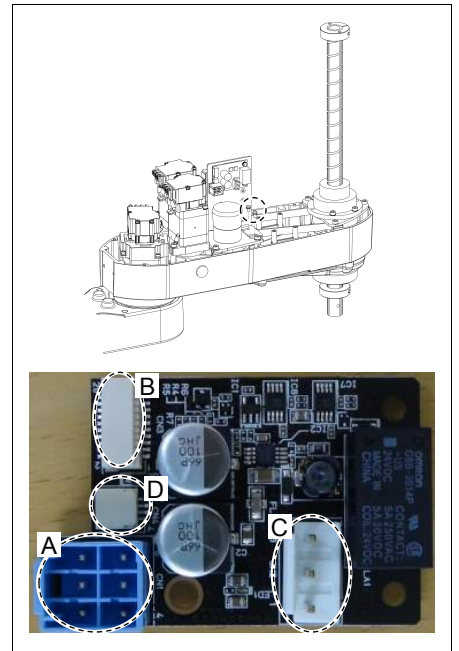

- (7) Loosen the Joint #3 motor unit mounting bolts.

3-M4×15+M4 washer

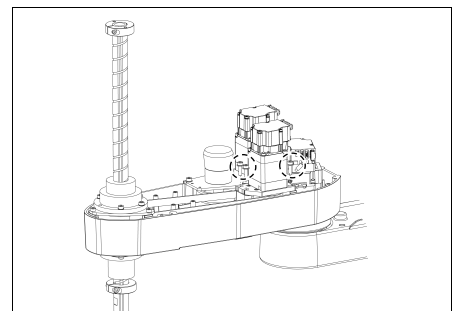

- (8) Loosen the Joint #4 motor unit mounting bolts.

3-M4x20+M4 washer

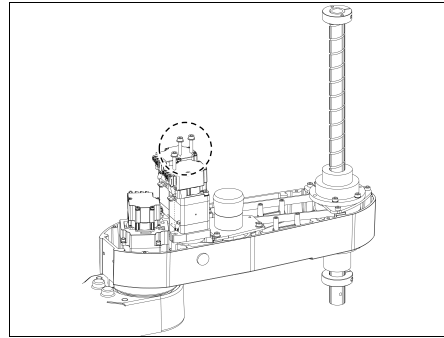

- (9) Unscrew the mounting screws of the joint #4 intermediate unit. Pull out the joint #4 intermediate unit and U1 belt upward.

3-M4x12+M4 washer

The washer will be necessary again when mounting the intermediate unit. Be sure to keep the washer.

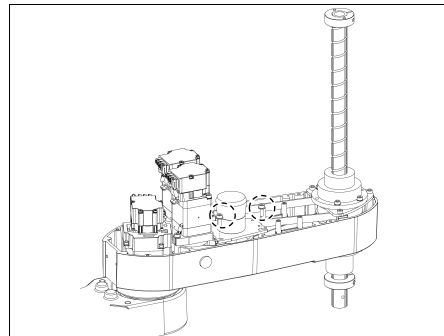

- (10) Remove the screws for the spline plate. Hold up the spline plate and pull out the Z belt and U2 belt.

3-M4x12

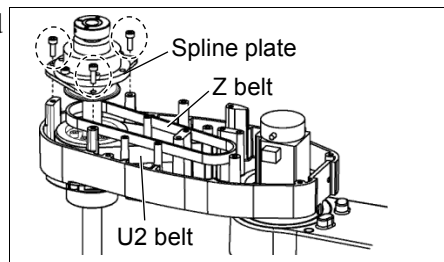

## U2 belt Installation

- (1) Hold up the spline plate and set the U2 belt around the U3 pulley.

Make sure the gear grooves of the belt are fit into those of the pulleys completely.

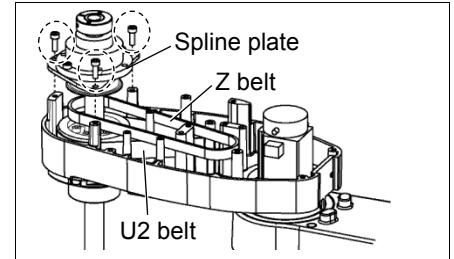

- (2) Hold up the spline plate and set the Z belt around the Z2 pulley.

Make sure the gear grooves of the belt are fit into those of the pulleys completely.

- (3) Loosely secure the spline plate on the Arm #2 and move the shaft up and down several times before firmly secure the spline plate.

3-M4x12

- (4) While the U1 belt is set around the large pulley of Joint #4 intermediate unit, set the U2 belt inside the arm #2 around the small pulley and put on the upper surface of the arm #2.

Make sure the gear grooves of the belt are fit into those of the pulleys completely.

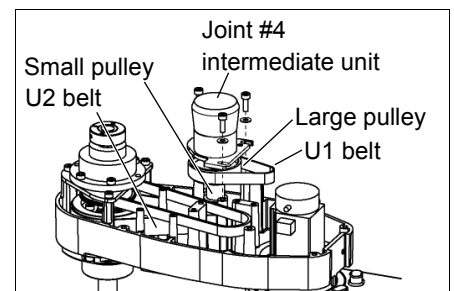

- (5) Loosely secure the Joint #4 intermediate unit by using screws.

3-M4x12+M4 washer

Make sure the Joint #4 intermediate unit can be moved by hand, and it will not tilt when pulled. If the unit is secured too loose or too tight, the belt will not have the proper tension.

- (6) Apply the proper tension to the U2 belt and secure the Joint #4 intermediate unit.

Set a suitable cord or string around the part near the plate of the Joint #4 motor unit near its mounting plate.

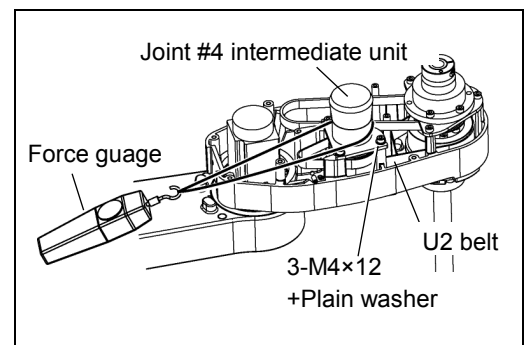

U2 belt tension:

51 N (5.2 ± 0.75 kgf)

Axial force (When pulling):

102.0 N (10.4 ± 0.75 kgf)

- (7) Apply the proper tension to the U1 belt, and secure the Joint #4 motor unit.

Pass a suitable cord or string around the Joint #4 motor unit near its mounting plate. Then, pull the cord using a force gauge or similar tool to apply the specified tension shown in the figure on the right.

U1 belt tension:  
 29.0 N (2.95 ± 0.5 kgf)

Axial force (When pulling):  
 58 N (5.9 ± 0.5 kgf)

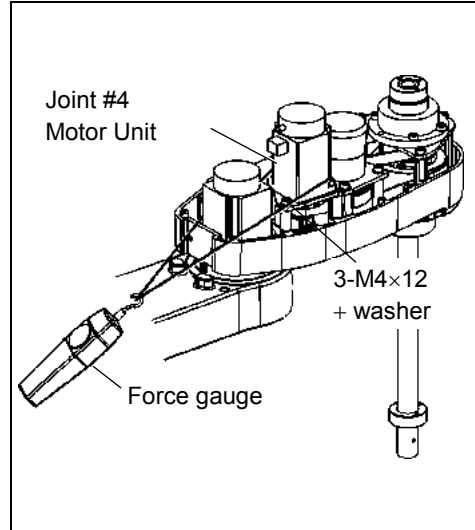

NOTE To check belt tension with the tension meter, refer to the following.  
 Maintenance: 12.3 Checking the Timing Belt Tension.

- (8) Apply the proper tension to the Z belt, and secure the Joint #3 motor unit.

Pass a suitable cord or string around the Joint #3 motor unit near its mounting plate. Then, pull the cord using a force gauge or similar tool to apply the specified tension shown in the figure on the right.

Z belt tension:  
 34.5 N (3.5 ± 0.5 kgf)

Axial force (When pulling):  
 69.0 N (7.0 ± 0.5 kgf)

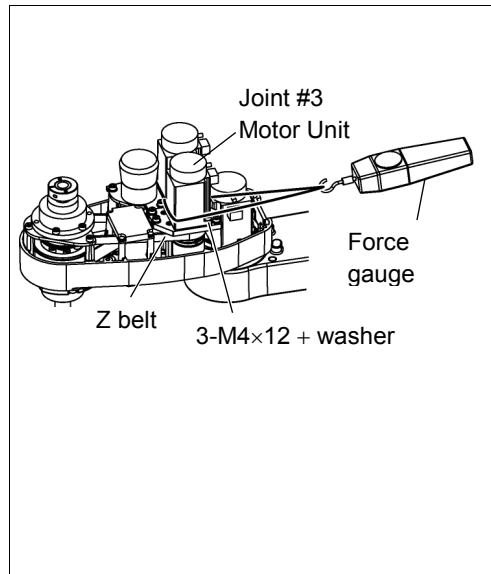

NOTE To check belt tension with the tension meter, refer to the following.  
 Maintenance: 11.4 Checking the Timing Belt Tension (Z Belt)

- (9) Mount the AMP board.

Sems bolt: 2-M3×6

Connect the AMP board to connectors.

A: Power cable connector (3 connectors)

B: AMP cable connector (3 connectors)

C: Motor cable connector (3 connectors)

D: Brake cable connector (1 connector)

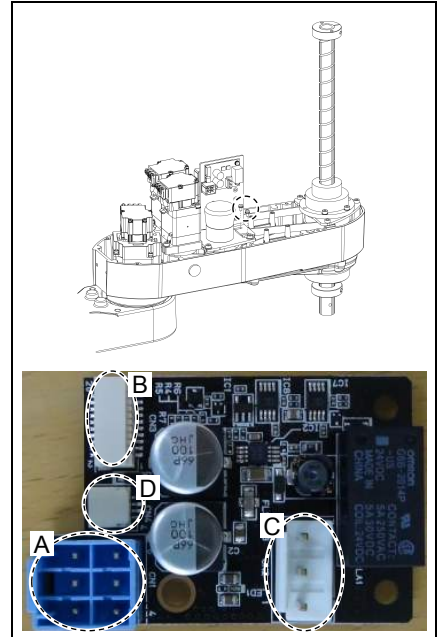

- (10) Mount the User Plate.

For details, refer to *Maintenance: 7.7 User Plate*.

- (11) Mount the Arm Top Cover.

For details, refer to *Maintenance: 7.1 Arm Top Cover*.

- (12) Execute the calibration of Joints #3, #4.

For details, refer to *Maintenance: 16. Calibration*

### 12.2.2 U1 Belt (T6)

#### U1 belt Removal

- (1) Remove the Joint #4 motor unit.

For details, refer to the following.

*Maintenance: 12.1 Replacing Joint #4 Motor “Joint #4 motor Removal”*

- (2) Remove the Joint #4 intermediate unit and the U1 belt.

For details, refer to the following.

*Maintenance: 12.2.1 U2 Belt (T6) “U2 belt Removal”*

#### U1 belt Installation

- (1) Apply the proper tension to the U2 belt, and secure the intermediate unit.

For details, refer to the following.

*Maintenance: 12.2.1 U2 Belt (T6) “U2 belt Installation”*

- (2) Apply the proper tension to the U1 belt, and secure the Joint #4 motor unit.

For details, refer to the following.

*Maintenance: 12.1 Replacing Joint #4 Motor “Joint #4 motor Installation”*

- (3) Execute the calibration of Joint #4.

For details, refer to the following.

*Maintenance: 16. Calibration*



### 12.2.3 U Belt (T3)

#### U belt Removal

- (1) Remove the Joint 4 motor unit.

For details, refer to *Maintenance*:

*12.1 Replacing Joint 4 Motor "Removal Procedure"*.

- (2) Loosen the Joint #3 motor unit mounting bolts.

a: 2-M4×15+M4 slotted hole washer

b: M3×12+M3 slotted hole washer

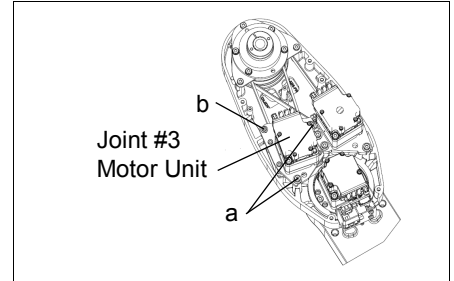

- (3) Remove the spline plate mounting screw.

3-M4×12

Hold up the spline plate, and then pull out the Z belt and U belt to the upper side.

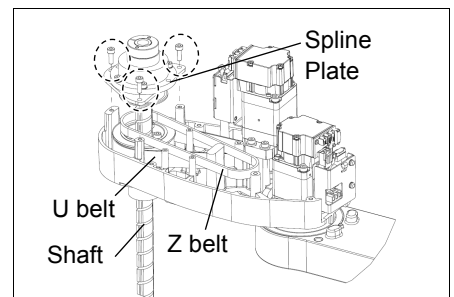

#### U belt Installation

- (1) Hold up the spline plate and set the U belt around the U2 pulley.

3-M4×12

Make sure the gear grooves of the belt are fit into those of the pulleys completely.

- (2) Hold up the spline plate and set the Z belt around the Z2 pulley.

Make sure the gear grooves of the belt are fit into those of the pulleys completely.

- (3) Loosely secure the spline plate on the Arm #2 and move the shaft up and down several times before firmly secure the spline plate.

- (4) Mount the Joint 4 motor unit.

For details, refer to *Maintenance*:

*12.1 Replacing the Joint 4 Motor "Installation Procedure"*.

- (5) Apply the proper tension to the Z belt and secure the Joint #3 motor unit.

For details, refer to *Maintenance*:

*11.1 Replacing the Joint 3 Motor "Installation Procedure"*.

- (6) Execute the calibration for Joint #3 and #4.

For details on the calibration method, refer to *Maintenance: 16. Calibration*.

### 12.3 Checking the Timing Belt Tension

	Name	Quantity	Note
Tool	Sonic tension meter	1	For details of usage and measurement methods of the tension meter, refer to the instruction manual of the tension meter.

Joint #4 (1) Enter appropriate setting values to the sonic tension meter.

Belt tension check

Model	Belt	Unit mass M [g/ (1 mm width ×1 m length)]	Width W [mm]	Span S [mm]
T3	U belt	1.3	17	127
T6	U1 belt	2.0	10	54
	U2 belt	2.0	15	170

- (2) T3: Strum the U belt and measure tension.
- T6: Strum the U2 belt and measure tension.

NOTE  Measurement failure may occur if the microphone touches the belt during measurement.

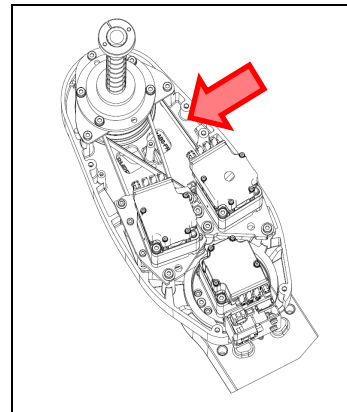

- (3) T6: Remove the rubber plug from the hole on the Arm #2.

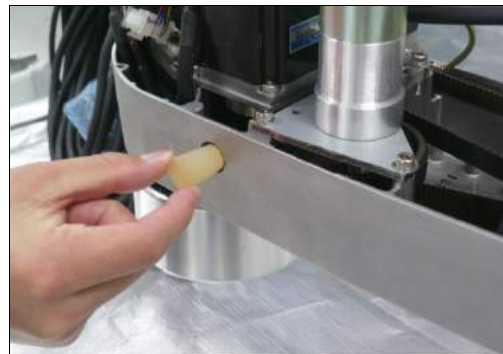

Strum the U1 belt and measure tension.

NOTE  Insert the microphone of the tension meter to the hole on the Arm to measure tension. Measurement failure may occur if the microphone touches the belt during measurement.



## 13. Ball Screw Spline Unit



WARNING

- Do not connect or disconnect the motor connectors while the power to the robot system is turned ON. Connecting or disconnecting the motor connectors with the power ON is extremely hazardous and may result in serious bodily injury as the Manipulator may move abnormally, and also may result in electric shock and/or malfunction of the robot system.
- To shut off power to the robot system, disconnect the power plug from the power source. Be sure to connect the AC power cable to a power receptacle. DO NOT connect it directly to a factory power source.
- Before performing any replacement procedure, turn OFF the Controller and related equipment, and then disconnect the power plug from the power source. Performing any replacement procedure with the power ON is extremely hazardous and may result in electric shock and/or malfunction of the robot system.

NOTE



After parts have been replaced (motors, reduction gear units, brakes, timing belts, ball screw spline unit, etc.), the Manipulator cannot operate properly because a mismatch exists between the origin stored in each motor and its corresponding origin stored in the Robot system.

Because of that, it is necessary to perform calibration (encoder rest and calibration) to match these origins.

Refer to *Maintenance: 16. Calibration* to perform the calibration.

### 13.1 Greasing the Ball Screw Spline Unit

	Name	Quantity	Note
Grease	For Ball Screw Spline Unit (AFB grease)	Proper quantity	
Tools	Wiping cloth	1	For wiping grease (Spline shaft)



The brake release switch affects only Joint #3. When the brake release switch is pressed, the Joint #3 brake is released.

Be careful of the shaft while the brake release switch is being pressed because the shaft may be lowered by the weight of the end effector

Cover the surrounding area such as the end effector and peripheral equipment in case the grease drips.

- (1) Turn ON the Manipulator. Stop motor excitation. (MOTOR OFF)
- (2) Move the arm to a position where Joint #3 can be moved in full stroke.
- (3) Move the shaft to its upper limit manually while pressing the brake release switch.
- (4) Turn OFF the Manipulator.

- (5) Wipe off the old grease from the upper part of the shaft, and then apply new grease to it.

When applying the new grease to the upper part of the shaft, directly fill the grooves on it by hand. Wipe off excess grease from the shaft.

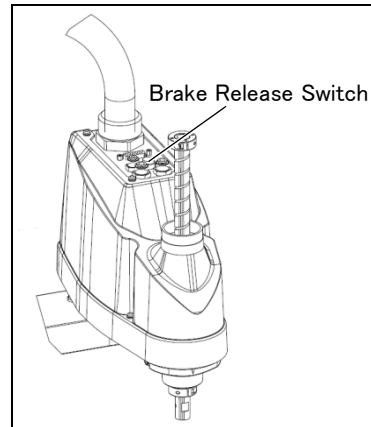

- (6) Turn ON the Manipulator.
- (7) Move the shaft to its lower limit by hand while pressing the brake release switch.
- (8) Wipe off the old grease from the lower part of the shaft, and then apply new grease to it.

When applying the new grease to the lower part of the shaft, directly fill the grooves on it by hand. Wipe off excess grease from the shaft.

- (9) Move the shaft up and down several times while pressing the brake release switch to smooth out the grease on the shaft. Wipe off excess grease from the shaft.

When wiping off the excess grease from the upper part of shaft, turn OFF the Manipulator and remove the Arm Top Cover.

For details, refer to *Maintenance: 7.1 Arm Top Cover*.

## 13.2 Replacing the Ball Screw Spline Unit

**NOTE**  A brake is mounted on the Joint #3 motor to prevent the shaft from lowering down due to the weight of the end effector while the power to the Manipulator is OFF or while the motor is in OFF status (MOTOR OFF).

However, brake does not work while the replacement operation. Move the shaft down to its lower limit before operating the replacement following the removal procedure (1) to (3).

	Name	Quantity	Note	
Maintenance part	Ball Screw Spline Unit	150st	1	T3: 1718877
		200st	1	T6: 1750572
Grease	For Ball Screw Spline Unit (AFB grease)	Proper quantity		
Tools	Hexagonal wrench (width across flats: 3 mm)	1	For M4 screw	
	Torque wrench	1		
	Cross-point screwdriver (No. 2)	1	For cross-recessed screw	
	Force gauge	1	Belt tension: Z, U: 69N (7.0 ± 0.5 kgf) U1: 58 N (5.9 ± 0.5 kgf) U2: 102 N (10.4 ± 0.75 kgf)	
	Suitable cord (Length about 1000 mm)	1	For belt tension	
	Wiping cloth	1	For wiping grease (Spline shaft)	
Material	Wire tie	-		

Ball Screw  
Spline Unit  
Removal

- (1) Turn ON the Manipulator.
- (2) Push down the shaft to its lower limit while pressing the brake release switch. Be sure to keep enough space and prevent the end effector hitting any peripheral equipment.

The brake release switch affects only Joint #3. When the brake release switch is pressed, the Joint #3 brake is released.

Be careful of the shaft while the brake release switch is being pressed because the shaft may be lowered by the weight of an end effector.

- (3) Turn OFF the Manipulator.
- (4) Detach the wires/tubes from the end effector, and remove the end effector.
- (5) Remove the Arm Top Cover and Arm Bottom Cover.

For details, refer to *Maintenance: 7. Covers*.

- (6) Remove three screws mounting the spline plate.

a: 3-M4×12

- (7) Remove four screws mounting the spline nut.

b: T3: 4-M4×10

T6: 4-M4×12

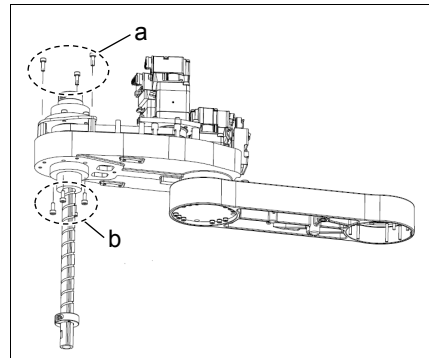

- (8) Pull out the following toward the Arm #2 upper side.

Ball screw spline unit   Z belt   U belt(T3)   U2belt(T6)

Ball Screw  
Spline Unit  
Installation

- (1) Insert a new ball screw spline unit in the Arm #2.
- (2) Secure the spline nut from the bottom side of the Arm #2.

T3: 4-M4×10

T6: 4-M4×12

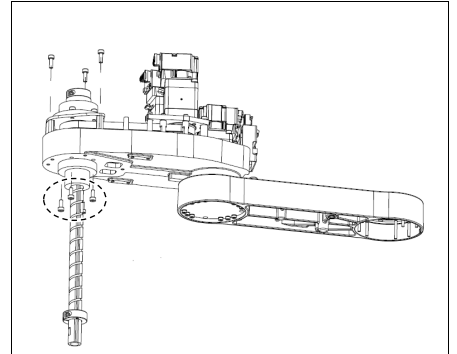

- (3) Mount the following.  
U belt (T3) U2 belt (T6) Z belt  
For details, refer to *Maintenance: 12.2 Replacing the Timing Belt “Installation”*.
- (4) Mount the Arm Top Cover and Arm Bottom Cover.  
For details, refer to *Maintenance: 7. Covers*.
- (5) Grease the shaft.  
For details, refer to *Maintenance 13.1: Greasing the Ball Screw Spline Unit*.
- (6) Mount the end effector, cables, and tubes.
- (7) Perform the calibration of Joints #3, #4.  
For details, refer to *Maintenance: 16. Calibration*.

## 14. Lithium Battery, SD Card, Boards, and Filter

 WARNING	<ul style="list-style-type: none"> <li>■ Do not connect or disconnect the motor connectors while the power to the robot system is turned ON. Connecting or disconnecting the motor connectors with the power ON is extremely hazardous and may result in serious bodily injury as the Manipulator may move abnormally, and also may result in electric shock and/or malfunction of the robot system.</li> <li>■ To shut off power to the robot system, disconnect the power plug from the power source. Be sure to connect the AC power cable to a power receptacle. DO NOT connect it directly to a factory power source.</li> <li>■ Before performing any replacement procedure, turn OFF the Controller and related equipment, and then disconnect the power plug from the power source. Performing any replacement procedure with the power ON is extremely hazardous and may result in electric shock and/or malfunction of the robot system.</li> </ul>
--	---

 WARNING	<ul style="list-style-type: none"> <li>■ Use meticulous care when handling the lithium battery. Improper handling of the lithium battery as mentioned below is extremely hazardous, may result in heat generation, leakage, explosion, or inflammation, and may cause serious safety problems.                      &lt;Improper Handling&gt;                     <table style="margin-left: 20px; border: none;"> <tr> <td>- Battery Charge</td> <td>- Deformation by Pressure</td> </tr> <tr> <td>- Disassembly</td> <td>- Short-circuit (Polarity; Positive/Negative)</td> </tr> <tr> <td>- Incorrect Installation</td> <td>- Heating (85°C or more)</td> </tr> <tr> <td>- Exposing to Fire</td> <td>- Soldering the terminal of the lithium battery directly</td> </tr> <tr> <td>- Forced Discharge</td> <td></td> </tr> </table> </li> <li>■ When disposing of the battery, consult with the professional disposal services or comply with the local regulation.                      Spent battery or not, make sure the battery terminal is insulated. If the terminal contacts with the other metals, it may short and result in heat generation, leakage, explosion, or inflammation.</li> </ul>	- Battery Charge	- Deformation by Pressure	- Disassembly	- Short-circuit (Polarity; Positive/Negative)	- Incorrect Installation	- Heating (85°C or more)	- Exposing to Fire	- Soldering the terminal of the lithium battery directly	- Forced Discharge	
- Battery Charge	- Deformation by Pressure										
- Disassembly	- Short-circuit (Polarity; Positive/Negative)										
- Incorrect Installation	- Heating (85°C or more)										
- Exposing to Fire	- Soldering the terminal of the lithium battery directly										
- Forced Discharge											

The life span of the lithium battery varies depending on the energizing hours and installation environment of the Manipulator. It is about 7 years as a rough guide (when the Manipulator is connected to power for 8 hours a day).

When the Manipulator is not connected to power, the battery consumption will significantly increase compared to when the Manipulator is energized. If warnings of voltage reduction occur, replace the lithium battery even if it has not reached the above product life.

**NOTE**  For the EPSON RC+ 7.0, the recommended replacement time for the battery can be checked in the [Maintenance] dialog box of the EPSON RC+ 7.0.  
 For details, refer to *Maintenance: 4. Alarm*.



The battery may run out if it passes the recommended replacement time.

If no warnings of voltage reduction occur, the calibration for all joints is not necessary. You need to perform calibration if the position moves from the originals after replaced the battery.

Always use the lithium battery and battery board designated by us.

Refer to *Maintenance: 19. Maintenance Parts List*.

Be careful of the battery polarity to connect it correctly.

### 14.1 Replacing the CPU/DPB Boards



**WARNING**

- Make sure that orange colored charge confirmation LED on the DPB turns off when eject the CPU or DPB. If operating without tuning off the LED, electric shock or other serious problems for safety may occur.

T3

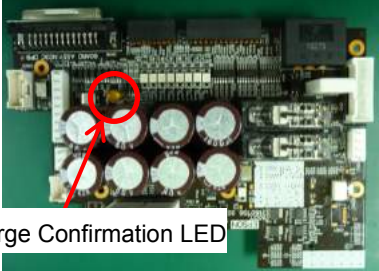

Charge Confirmation LED

T6

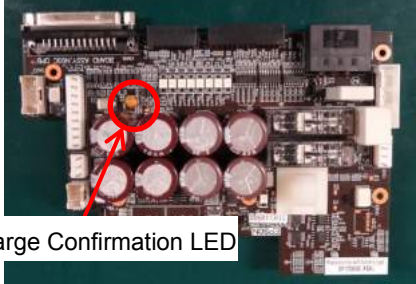

Charge Confirmation LED

	Name	Quantity	Note
Maintenance part	CPU/DPB boards	1	T3: 2182747 T6: 2191143
Tools	Hexagonal wrench   width across flats: 2 mm	1	For M3 button bolt
	Cross-point screwdriver	1	

CPU/DPB Boards (1) Turn OFF the Manipulator.

Replace

(2) Remove the connector plate.

For details, refer to *Maintenance 7.4 Connector Plate*

(3) Remove the following parts that connected to the Connector Plate.

- Air tube
- TP connector

(4) Remove the CPU/DPB board mounting screws.

Hexagon socket head cap button bolt: 5-M3x5

Remove the CPU/DPB boards from the base.

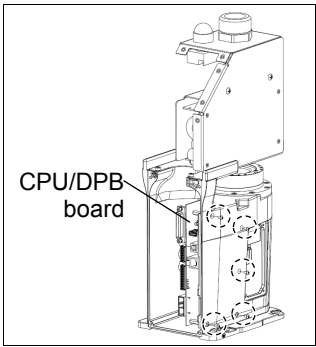

T6: Disconnect the connector of regenerative resistor junction cable. Then, remove the regenerative resistor fixing plate.

2-M4x8 Sems

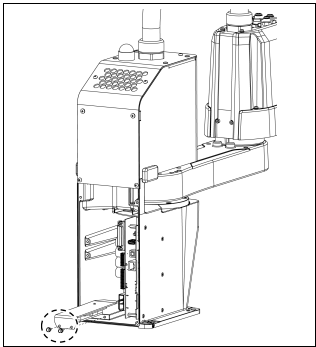

- (5) Remove the CPU/DPB board connector.

- A: Power connector (IN/OUT×1 for each)
- B: Power cable connector (×2)
- C: Signal cable connector
- D: Hand I/O connector
- E: LED connector
- F: Regenerative resistor 1 (T6 only)
- G: Regenerative resistor 2 (T6 only)

**NOTE**  Remember the cable layout for reconnecting after replacement.

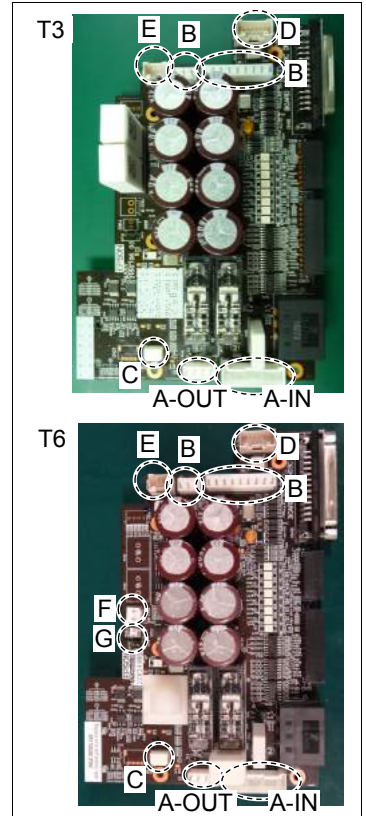

- (6) Remove the radiation sheet attached on the CPU board.

**NOTE**  Radiation sheet will be used again. Be sure to keep the sheet.

Be careful not to break the radiation sheet.

- (7) Attach the radiation sheet on the face of new CPU/DPB board connectors do not come out.

Be careful not to attach the sheet on the wrong face.

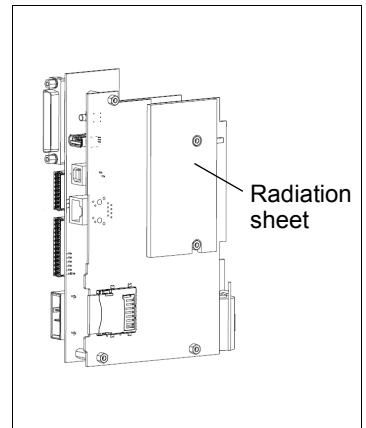

(8) Connect the CPU/DPB board connectors.

- A: Power connector (IN/OUT×1 for each)
- B: Power cable connector (×2)
- C: Signal cable connector
- D: Hand I/O connector
- E: LED connector
- F: Regenerative resistor 1 (T6 only)
- G: Regenerative resistor 2 (T6 only)

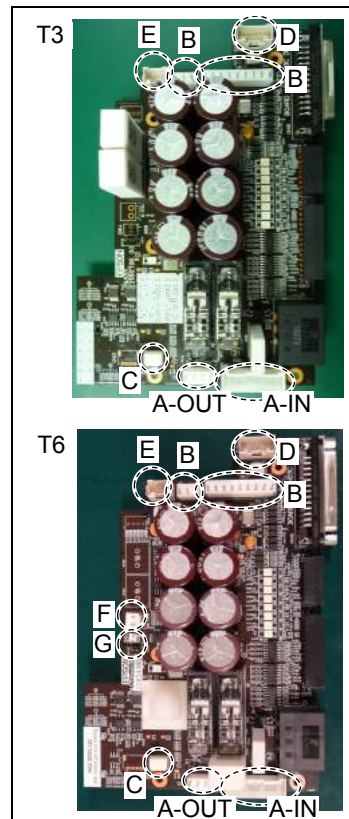

(9) Mount CPU/DPB board on a base.

- Hexagon socket head cap button bolt: 5-M3x5
- Tightening torque:  $0.45 \pm 0.1 \text{ N}\cdot\text{m}$

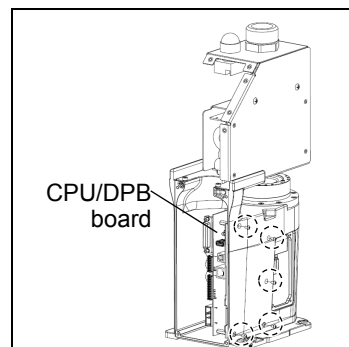

(10) T6: Mount the regenerative resistor fixing plate and connect the connector of regenerative resistor junction cable.

- 2-M4×8 Sems

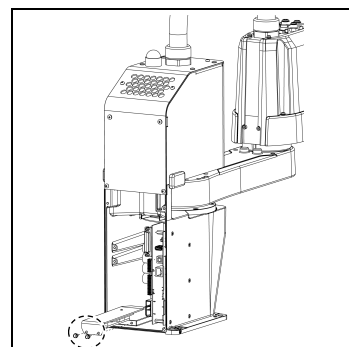

(11) Connect the following part to the inside of the connector plate.

- Air tube
- TP connector

(12) Mount the connector plate.

For more details, refer to *Maintenance 7.4 Connector Plate*

## 14.2 Replacing the Lithium Battery

	Name	Quantity	Note	
Maintenance part	Lithium Battery	1	2113554	
Tools	Hexagonal wrench	width across flats: 2 mm	1	For M3 button bolt
	Cross-point screwdriver		1	

**NOTE** Replace the battery within 30 minutes after turning OFF.



If more than 30 minutes pass after removing the battery, voltage of the capacitor lower and time may be reset.

Battery unit  
(lithium battery)  
Replace

(1) Remove the CPU/DPB board from the base.

For more details, refer to *Maintenance 14.1 Replacing the CPU/DPB Boards*

(2) Remove the battery connector and connect the new one.



(3) Mount the CPU/DPB board to the base.

For more details, refer to *Maintenance 14.1 Replacing the CPU/DPB Boards*

### 14.3 Replacing the SD Card

	Name	Quantity	Note
Maintenance part	SD card	1	2182748
Tool	Cross-point screwdriver (No.2)	1	

**NOTE**  Remove the SD card after removing the fieldbus I/O module if fieldbus I/O module is inserted to the option slot. Also, install fieldbus I/O module after installing the SD card.

For more details about fieldbus I/O module, refer to the following.

*Setup & Operation 17: Fieldbus I/O.*

#### SD Card Removal

- (1) Turn OFF the Manipulator.
- (2) Remove the power plug.
- (3) Remove the optional slot cover on the back face of the Manipulator.

Sems bolt: 2-M3×6

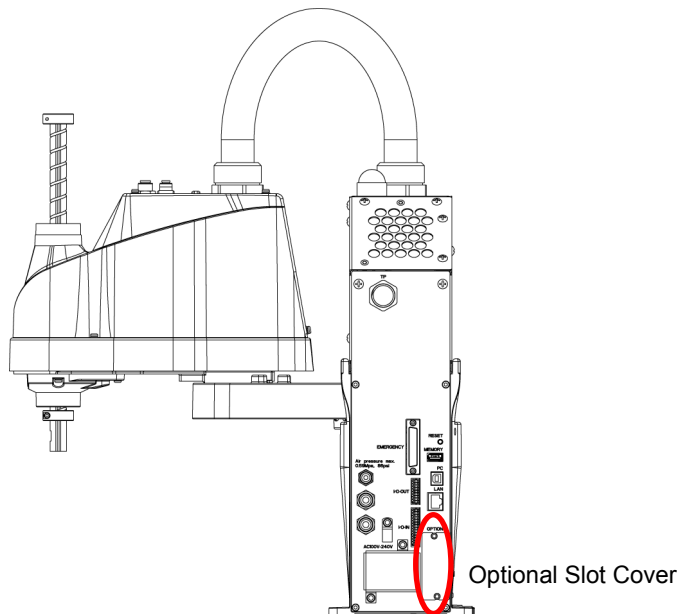

(Illustration: T3-401S)

- (4) Push the SD card which is inserted near the option slot to eject.

#### SD Card Installation

- (1) Push the SD card and inset to the SD card slot near the optional slot.
- (2) Mount the optional slot cover by screws.

Sems bolt: 2-M3×6

## 14.4 Replacing the Power Board

### 14.4.1 Replacing the Air Filter

	Name		Quantity	Note
Maintenance part	Air Filter		1	T3: 1713720
				T6: 1743656
Tool	Hexagonal wrench	Width across flats: 2.5 mm	1	For M4 button bolt
	Cross-point screwdriver (No. 2)		1	For truss screw

#### Air Filter Replace

- (1) Turn OFF the Manipulator.
- (2) Remove the Power Unit Cover.

For details, refer to *Maintenance: 7.5 Power Unit Cover*.

- (3) Remove the filter cover.

T3: Sems bolt: 2-M4×8

T6: Hexagon socket head cap button bolt:  
2-M4×10

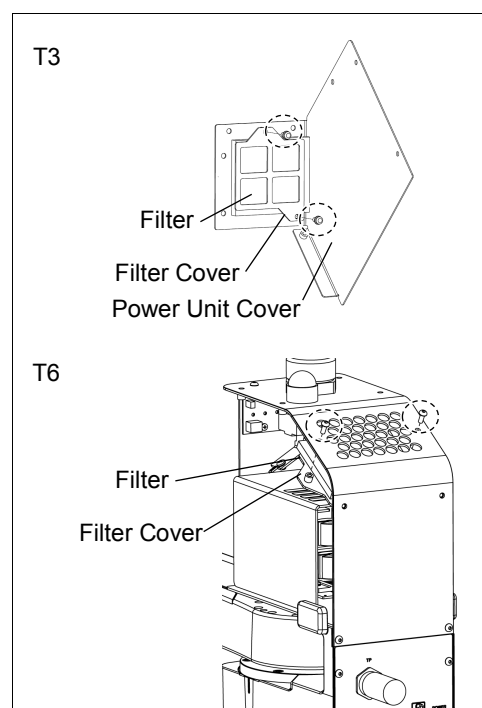

- (4) Remove the filter.
- (5) Set a new or clean filter to the filter cover and mount on the filter cover.

T6: Hexagon socket head cap button bolt  
Tighten torque:  $2.0 \pm 0.1$  N·m

- (6) Mount on the Power Unit Cover.

For details, refer to *Maintenance: 7.5 Power Unit Cover*.

### 14.4.2 Replacing the Power Board

	Name	Quantity	Note
Maintenance part	Power Board	1	T3: 2182749
		2	T6: 2188638
Tool	Cross-point screwdriver (No. 2)	1	For cross-recessed screw
	Spanner (width across flats: 5.5mm)	1	For hexagonal posts

**Power Board Replace**

- (1) Turn OFF the Manipulator.
- (2) Remove the Power Unit Cover.

For details, refer to *Maintenance: 7.5 Power Unit Cover*.

- (3) Remove the Power Board Cover.

T3: Truss screw: 2-M4×6

T6: Binding head screw: 2-M3×6

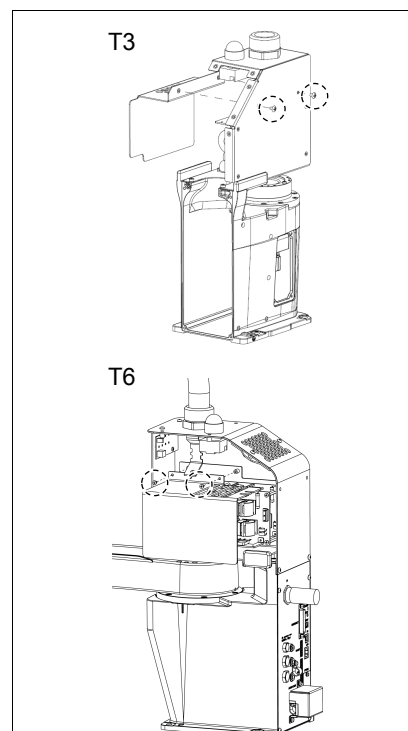

- (4) Remove the connectors of the Power board.

Power connector (IN/OUT ×1 for each)



T6: Power Board is two-stage structure. Remove the upper connector.

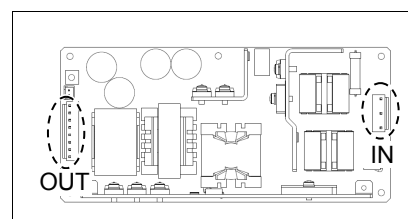

- (5) T3: Remove the Power Board.

Bind-head small screw: 4-M3×10

T6: Firstly, remove the upper power board.

Binding head screw: 4-M3×10

Next, remove the hexagonal posts. Then, remove the lower power board and connector.

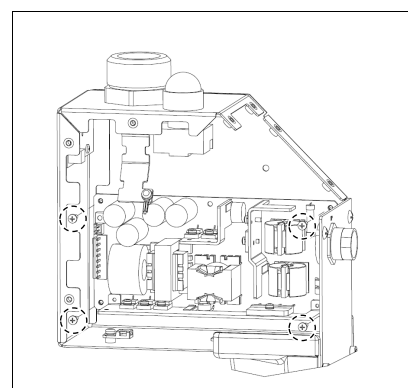



- (6) Mount new Power Board.

Bind-head small screw:4-M3×10

- (7) Connect the Power Board Connector.

Power connector (IN/OUT ×1 for each)

- (8) Mount the Power Board Cover.

T3: Truss screw: 2-M4×6

T6: Binding head screw: 2-M3×6

- (9) Mount the Power Unit Cover.

For details, refer to *Maintenance: 7.5 Power Unit Cover*.

## 15. LED Lamp Unit

 WARNING	<ul style="list-style-type: none"> <li>■ Do not connect or disconnect the motor connectors while the power to the robot system is turned ON. Connecting or disconnecting the motor connectors with the power ON is extremely hazardous and may result in serious bodily injury as the Manipulator may move abnormally, and also may result in electric shock and/or malfunction of the robot system.</li> <li>■ To shut off power to the robot system, disconnect the power plug from the power source. Be sure to connect the AC power cable to a power receptacle. DO NOT connect it directly to a factory power source.</li> <li>■ Before performing any replacement procedure, turn OFF the Controller and related equipment, and then disconnect the power plug from the power source. Performing any replacement procedure with the power ON is extremely hazardous and may result in electric shock and/or malfunction of the robot system.</li> </ul>
--	---

	Name	Quantity	Note
Maintenance part	LED Lamp Unit	1	2182673
Tools	Cross-point screwdriver (No. 2)	1	For cross-recessed screw
	Nippers	1	
Material	Wire tie	1	

- LED Lamp Unit Replace
- (1) Turn OFF the Manipulator.
  - (2) Remove the Power Unit Cover.

For details, refer to *Maintenance: 7.5 Power Unit Cover*.

- (3) Remove the LED Board Connector.

A: LED - .LED Board Connector.

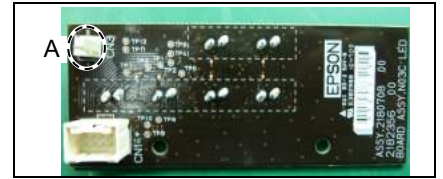

- (4) Disconnect the X1 and X2 terminals from the LED.

- (5) Turn the lens counterclockwise to remove. Then, turn the lens holder counterclockwise to remove.

- (6) Remove the LED and ring from the Power Unit.

- (7) Connect the X1 and X2 terminals to the new LED.

Each terminal must be connected to the same terminal number on the LED.

- (8) Put the User Plate between the ring and lens holder, and then secure the LED to the cover.

- (9) Mount the lens.

- (10) Connect the LED board connector.

LED - .LED Board Connector.

- (11) Remove the Power Unit Cover.

For details, refer to *Maintenance: 7.5 Power Unit Cover*.

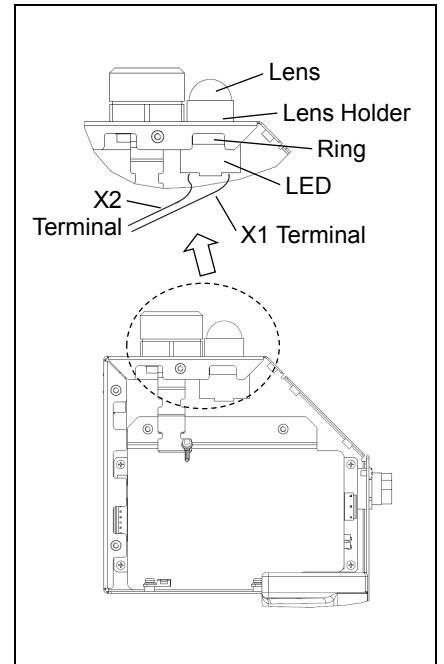

# 16. Calibration

## 16.1 About Calibration

After parts have been replaced (motors, reduction gear units, a brake, timing belts, ball screw spline unit, etc.), the Manipulator cannot execute the positioning properly because a mismatch exists between the origin stored in each motor and its corresponding origin stored in the Robot system.

Because of that, it is necessary to perform calibration (encoder rest and calibration) to match these origins. Note that calibration is not the same as teaching\*.

\*: “Teaching” means to teach the Manipulator coordinate points (including poses) anywhere in the operating area of the Manipulator.

 WARNING	<ul style="list-style-type: none"><li>■ To ensure safety, a safeguard must be installed for the robot system. For details on the safeguard, refer to EPSON RC+ User’s Guide: <i>2.4 Installation and Design Precautions</i>.</li><li>■ Before operating the robot system, make sure that no one is inside the safeguarded area. The robot system can be operated in the mode for teaching even when someone is inside the safeguarded area. The motion of the Manipulator is always in restricted (low speeds and low power) status to secure the safety of an operator. However, operating the robot system while someone is inside the safeguarded area is extremely hazardous and may result in serious safety problems in case that the Manipulator moves unexpectedly.</li></ul>
--	---

### Command Input

Calibration procedures include the process to input commands. Select EPSON RC+ menu-[Tools]-[Command Window] to use the command window.

The information above is omitted in the calibration procedure.

### Jog Motion

The process to set the jog motion is included in the [Jog & Teach] page of the Robot Manager. Select EPSON RC+ menu-[Tools]-[Robot Manager] and select the [Jog & Teach] tab to use the [Jog & Teach] page.

The page above is indicated as [Jog & Teach] in the calibration procedure.

## 16.2 Calibration Procedure

EPSON RC+ has a wizard for calibration.

This section indicates the calibration using the calibration wizard of EPSON RC+.

The same calibration procedure is used for each joint.

The follow the steps below are calibration using Joint #1. Follow the steps below to calibrate other joints.

When coordinates for the Manipulator working point require calculation, it is important for Joint #2 to be calibrated accurately. Execute the procedure in “Calibration Using Right / Left Arm Orientations” to accurately calibrate Joint #2. For details, refer to *Maintenance: 16.3 Accurate Calibration of Joint #2*.

When calibrating Joint #4, you must calibrate Joint #3 and #4 at the same time. You cannot calibrate Joint #4 alone because of the structure of the Manipulator.



If Err9716 or 5016 (Power supply failure of the absolute encoder. Replace the battery. Check the robot internal wiring) occurs, apply the procedure of *Maintenance: 16.4 Calibration Procedure without using Calibration Wizard - 3. Encoder Initialization* and then, start the calibration wizard.

The reference point (a point to check the accuracy) needs to be specified for calibration.

- (1) Start the calibration wizard.
  - i. Select EPSON RC+ 7.0 menu-[Setup]-[System Configuration] to display the [System Configuration] dialog.
  - ii. Select [Robot]-[Robot\*\*]-[Calibration] to display [Robot\*\*: Calibration].
  - iii. Select the joint and click the <Calibrate...> button.

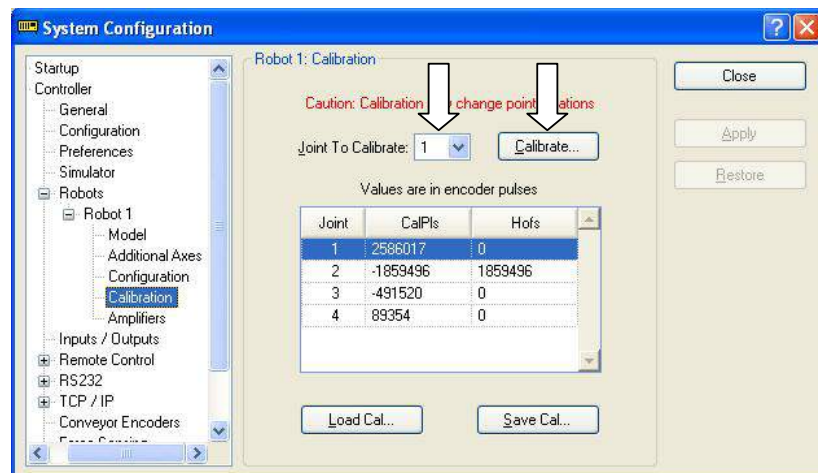

- (2) Confirm the warning message and click the <Yes> button.

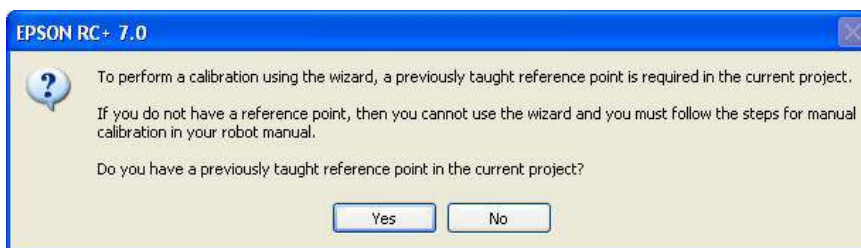

- (3) Move the joint to calibrate manually to approximate zero position, as shown in the dialog. After moving the joint click the <Next> button.

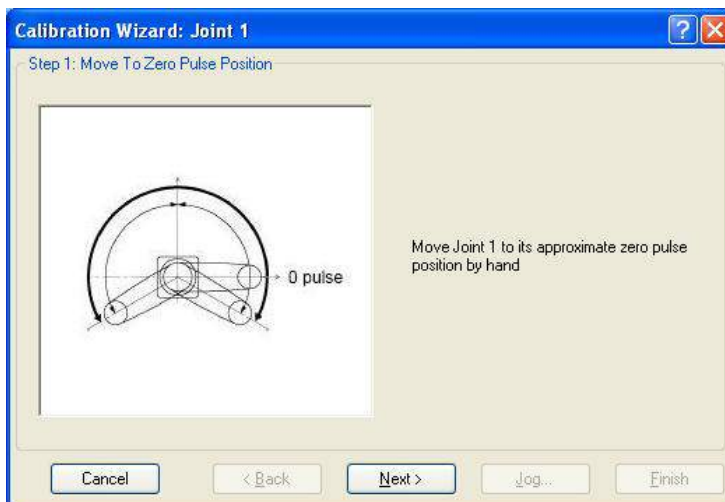

0 pulse position of Joint #1:  
position aligned with X-axis in  
Robot coordinate system

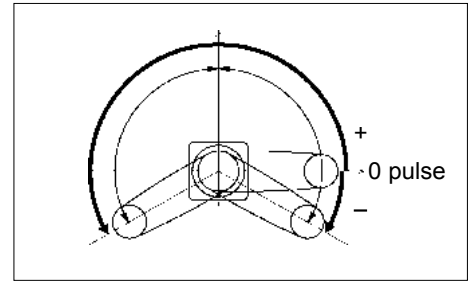

0 pulse position of Joint #2:  
position where Arms #1 and #2  
are in a straight line  
(Regardless of the Joint #1  
direction.)

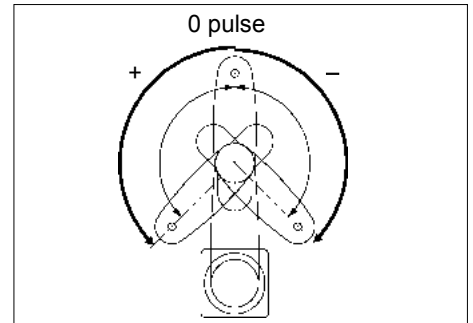

0 pulse position of Joint #3:  
upper limit position in motion  
range

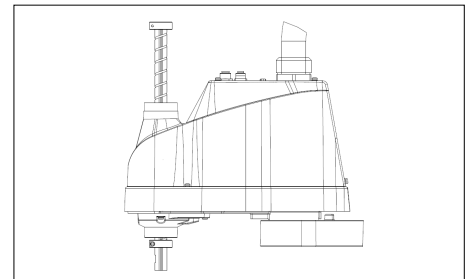

The height of Joint #3 depends  
on manipulator.

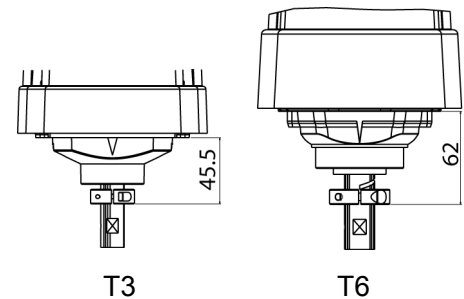

0 pulse position of Joint #4:  
position where the flat surface  
(or groove in the up/down  
mechanical stop) on the shaft  
faces toward the tip of Arm #2

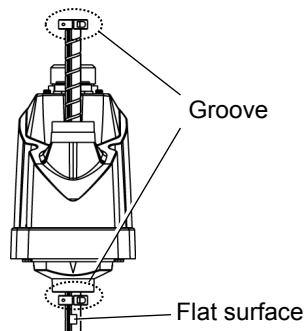
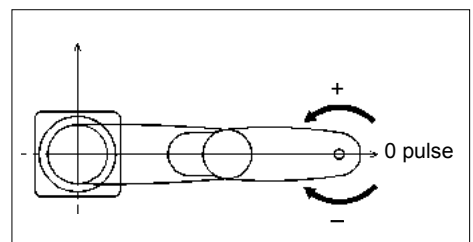

- (4) Click the <Yes> button to reset the encoder.

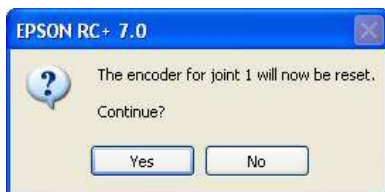

- (5) Restart the Controller (Manipulator).



\* This window will disappear when the Controller starts up.

- (6) Select the reference point to use for calibration, and click the <Next> button.

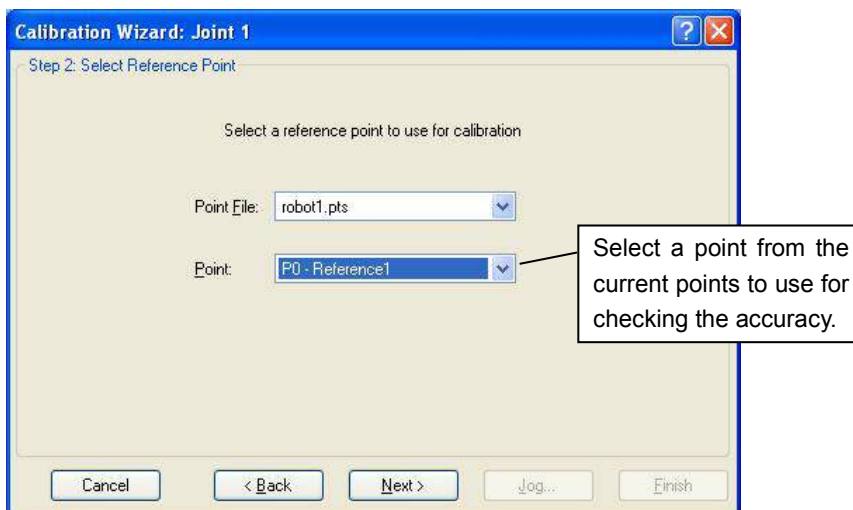

- (7) Click the <Jog...> button to display the [Jog & Teach] dialog.

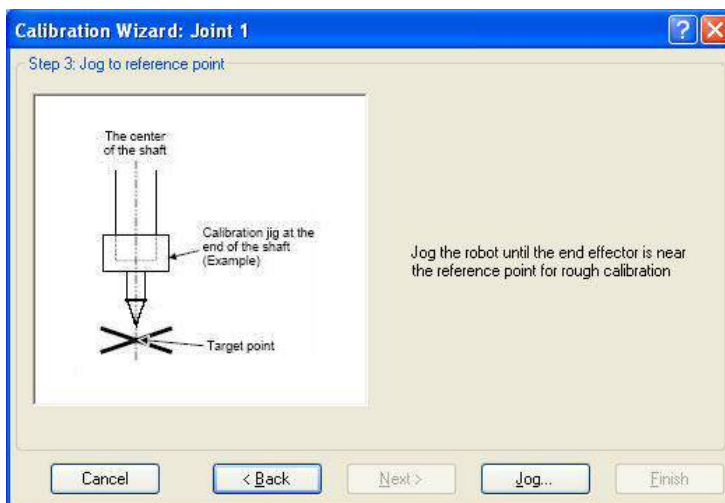



- (8) Jog the end effector to approximate reference point in the [Jog & Teach] dialog for rough calibration. Then click the <OK> button.

Before operating the robot, open the [Control Panel] and click on the <Motor ON> button.

NOTE



Move the end effector from the zero pulse position to the approximate reference point where rough calibration will be executed at by the jog motion. Position gap may occur if the end effector is not moved by the jog motion.

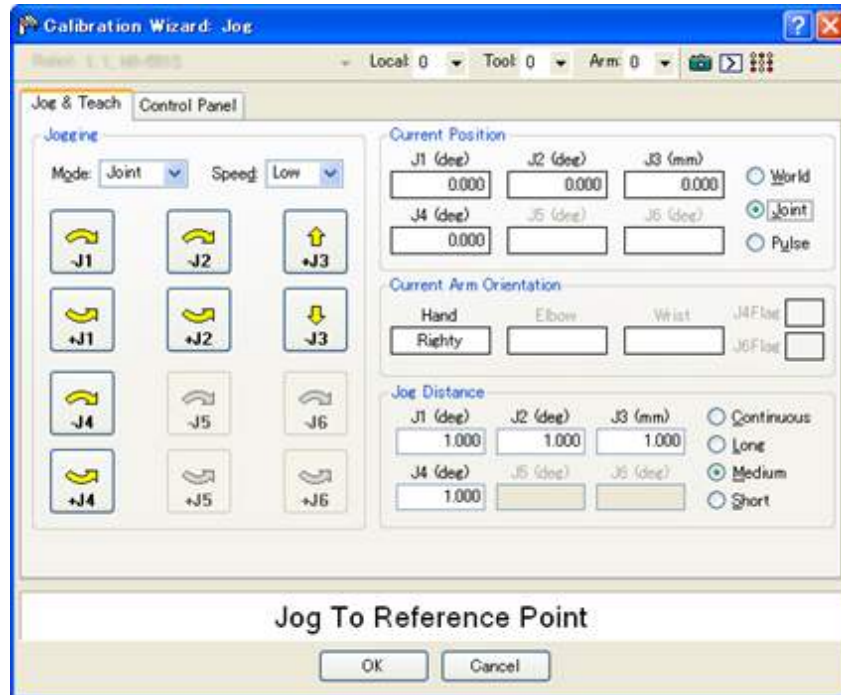

- (9) Click the <Next> button.

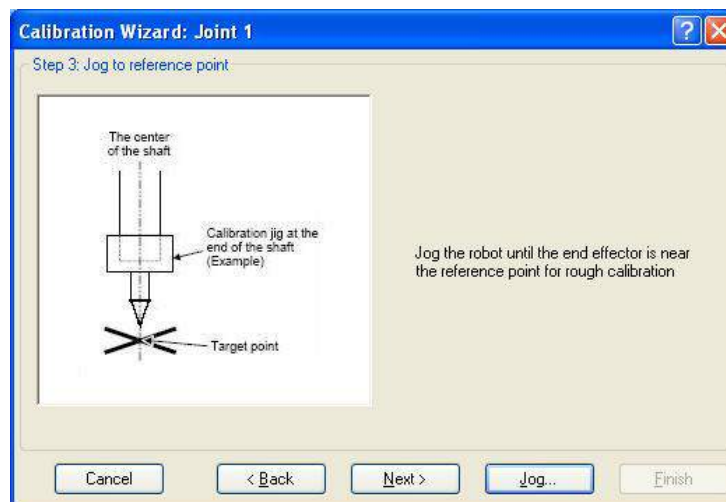

(10) The manipulator moves to the reference point. Click the <Execute> button.

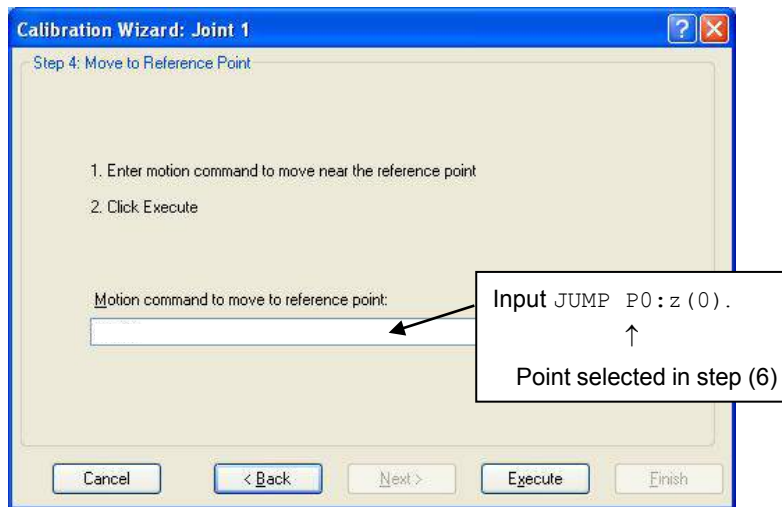

(11) Confirm the message and click the <Yes> button.

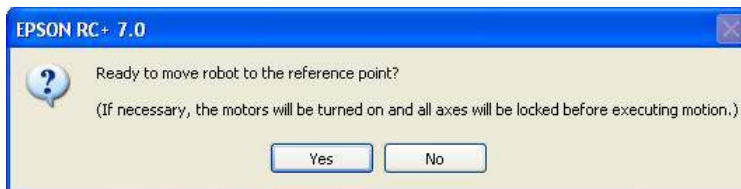

(12) After the manipulator moves to the reference point, click the <Next> button.

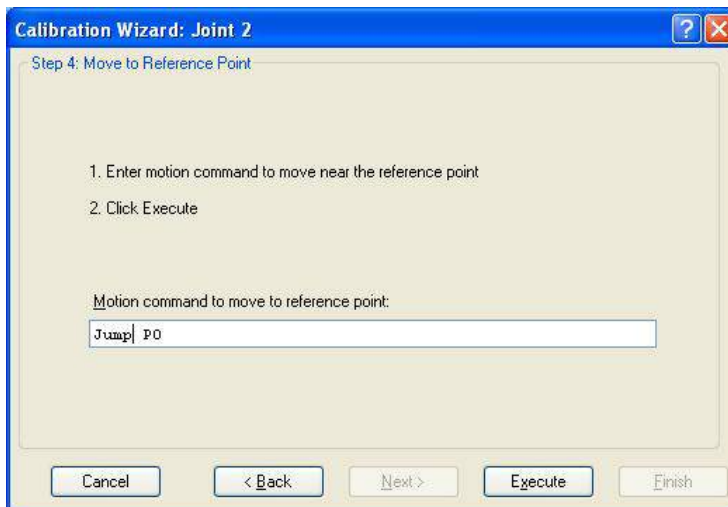

(13) Jog to the accurate reference position.

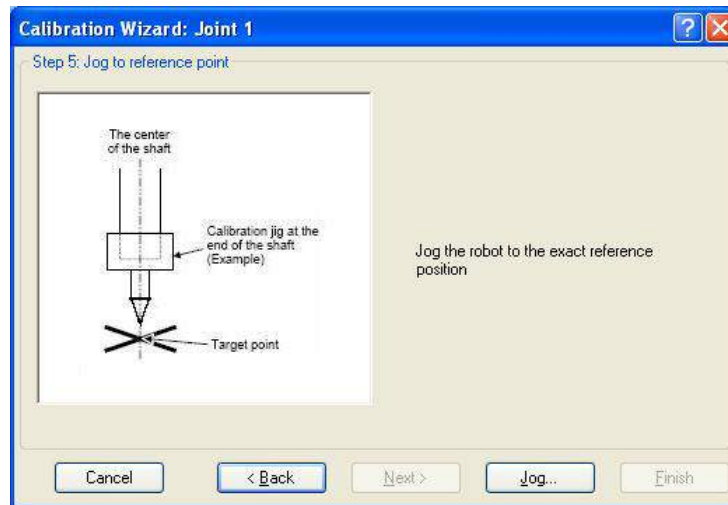

(14) Jog the end effector to approximate reference point in the [Jog & Teach] dialog for rough calibration. Then click the <OK> button.

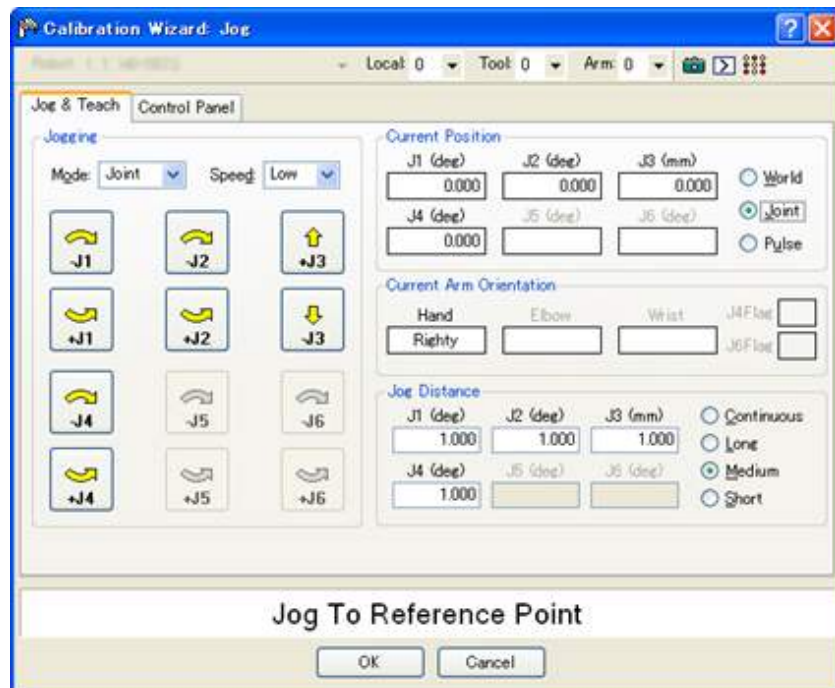

\* Position Joint #2 only and move Joint #3 to around 0 pulse.

(15) Click the <Next> button.

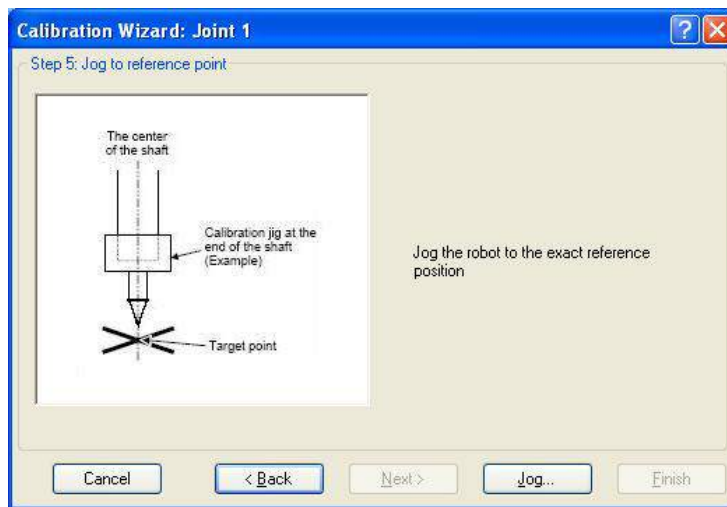

(16) Execute the procedure in “Calibration Using Right / Left Arm Orientations” to accurately calibrate Joint #2.

Go on to the step (17) for the other joints calibration.

i. Move to another point that has different pose (from righty to lefty) using Jump command. Click the <Yes> button.

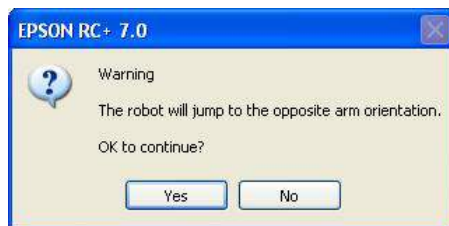

ii. Jog to the accurate reference position.

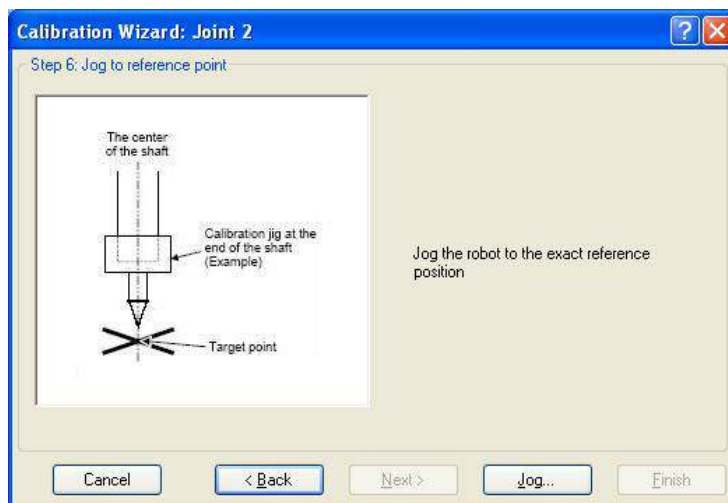

- iii. Jog to the accurate reference position and adjust the position. Click the <OK> button.

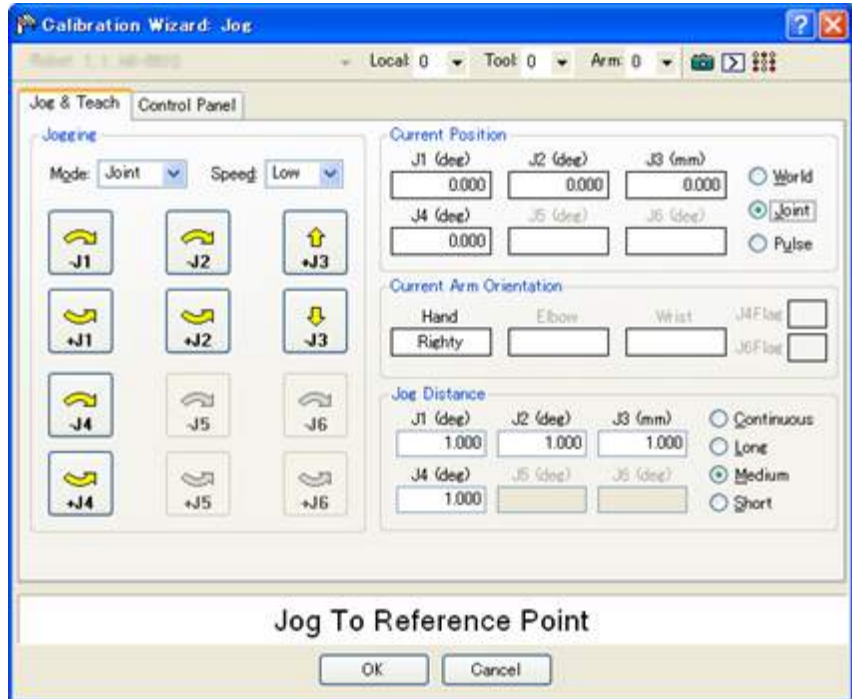

- iv. Click the <Next> button.

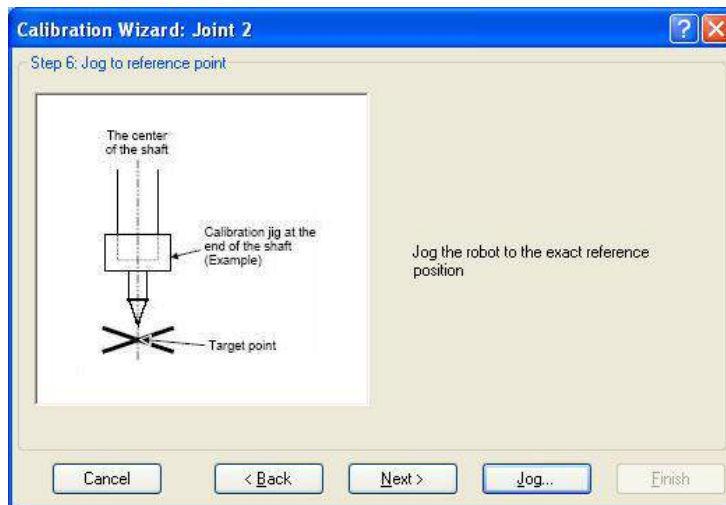

(17) Calibration is complete. Click the <Finish> button.



(18) Move the manipulator to other points and check if it can move without problems.  
Teach points where appropriate.

## 16.3 Accurate Calibration of Joint #2

When coordinates for the Manipulator working point require calculation, it is important for Joint #2 to be calibrated accurately.



If the accuracy of Joint #2 is not obtained through the steps in the section *Maintenance: 16.2 Calibration Procedure*, follow the steps below “Calibration Using Right / Left Arm Orientations” to accurately calibrate Joint #2.

The reference point is the center of the ball screw spline shaft during this calibration.

When there is a misalignment between the center of the end effector and the center of the ball screw spline shaft, remove the end effector and execute the calibration of the shaft.

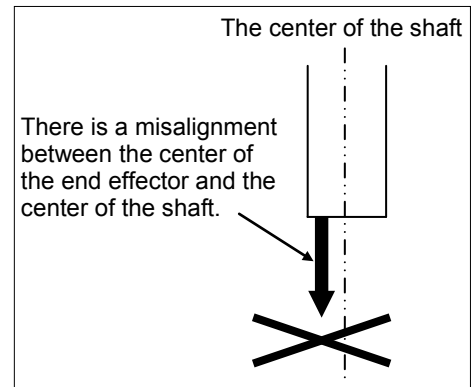

Make a calibration jig as shown in the right figure and attach it on the end of the shaft to make the center of the shaft clear.

Decide a target point and mark a cross (×) on it so that you can easily verify the center of the shaft after switching the arm pose between right and left.

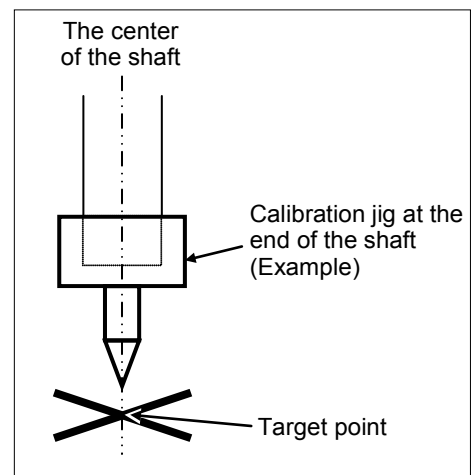

After removing the end effector and executing the calibration, install the end effector and move the Manipulator to the teaching point to verify whether there is a positional gap. If there is a positional gap, fine-tune the installation position of the end effector and teach the point again.

Coordinates for the working point requires calculation in the following cases:

- Teaching the working point by entering the coordinate values (MDI teaching)
- Switching the arm orientation between right and left at a given point
- Using the Pallet command
- Executing CP control (such as linear or circular interpolation)
- Using the Local command
- Pose data specified with relative coordinates <Example: P1+X(100) >
- Vision Guide camera calibrations

## Calibration Using Right / Left Arm Orientations

- (1) Check the point data for calibration

Use a point you can easily verify the accuracy within the work envelop of both right and left arm. Then, check the number of points you want to use.

- (2) Open the Tools menu | Robot Manager | Control Panel and click the MOTOR ON.
- (3) Click the <Free All> button to free all joints from servo control. Now, you can move arms by hands.

- (4) Move the arms to the position of point data for calibration in rightly arm orientation.

- (5) From the current position, teach any point data number unused.

This point is now called P1.

Specify the point number “1” and click the <Teach> button in the [Jog & Teach].

- (6) Click the Lock All in the [Control Panel] to lock all joints under servo control.

- (7) Switch to the lefty arm orientation. Then, move the arm to the same point.

>Jump P1/L:Z(0) ' Change the arm orientation from righty to lefty  
Z is the maximum position

\* If there is interference on the way from right to lefty, click the Free All in the [Control Panel] and change the arm orientation to lefty by hands. Then, go to the step (6), (7).

- (8) The joints are slightly out of position.

Adjust the gap with the -Z in the Jogging group in the [Jog & Teach]. Then, teach another point data number unused. This point is now called P2.

Specify point number “P2” and click the <Teach> button in [Jog & Teach].

- (9) Input the new Hofs value.

>Hofs Hofs (1), Hofs (2) + (Ppls(P1,2) + Ppls(P2,2)) /  
2, Hofs(3), Hofs(4)

- (10) From the current lefty arm orientation (the position in the step (8)), teach the point data number used in the step (8). This point is called P2.

Specify point number “P2” and click the <Teach> button in [Jog & Teach].

- (11) Switch to the righty arm orientation. Then, make sure the manipulator move to the correct position.

>Jump P2/R ' Change the arm orientation from lefty to righty

\* If there is any interference on the way from lefty to righty, click the Free All in the [Control Panel] and change the arm orientation to righty by hands. Then, go to the step (6), (11).

- (12) Move the manipulator to other point data and make sure it moves to the correct position. Teach some more points if required.

\* Delete the two points taught for the Joint #2 calibration.



## 16.4 Reference: Calibration Procedure Without Using Calibration Wizard



This section indicates the calibration without using the calibration wizard of EPSON RC+. For details of calibration using the calibration wizard, refer to *Maintenance: 16.2 Calibration Procedure*.

When coordinates for the Manipulator working point require calculation, it is important for Joint #2 to be calibrated accurately. Execute the procedure in “Calibration Using Right / Left Arm Orientations” to accurately calibrate Joint #2. For details, refer to *Maintenance: 16.3 Accurate Calibration of Joint #2*.

You cannot calibrate Joint #4 alone because of the structure of the Manipulator. When calibrating Joint #4, you must calibrate Joint #3 and #4 at the same time.



The reference point (a point to identify the position of the Manipulator) needs to be specified for calibration.

Follow steps 1 to 6 described below in order to calibrate the origin.

### 1. Basic Pose Confirmation

(1)-1 After the part replacement, execute the calibration using the point data currently registered.

Confirm the point data number (P\*) to reconstruct the correct manipulator position.

\* Point data before the parts replacement (motor, reduction gear, belt, etc.) is necessary for the calibration.

### 2. Part Replacement

(2)-1 Replace parts as dictated by this manual.

\* Be careful not to injure yourself or damage parts during part replacement.

### 3. Encoder Initialization

(3)-1 Turn ON the Manipulator when all joints are in the motion range.

(3)-2 Manually move the joint that needs origin alignment to its approximate 0 pulse position.

0 pulse position of Joint #1:  
position aligned with X-axis in Robot coordinate system

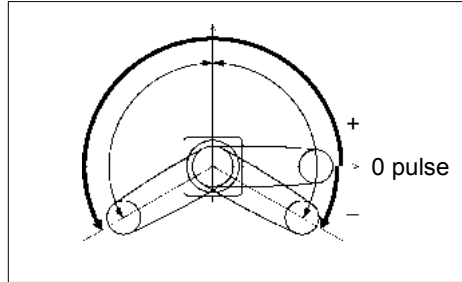

0 pulse position of Joint #2:  
position where Arms #1 and #2 are in a straight line  
(Regardless of the Joint #1 direction.)

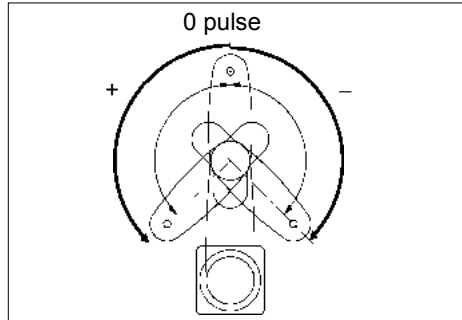

0 pulse position of Joint #3:  
upper limit position in motion range

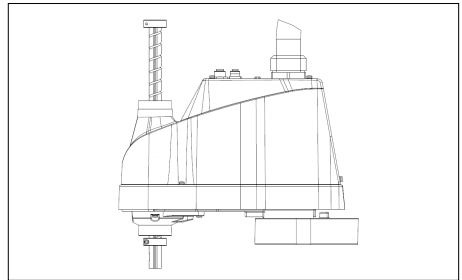

The height of Joint #3 is different depending on manipulator.

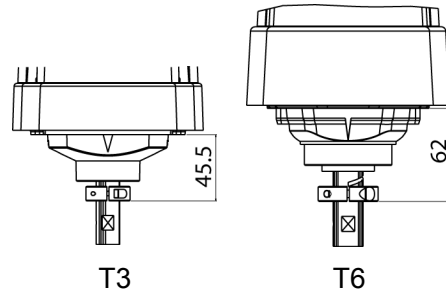

0 pulse position of Joint #4:  
position where the flat surface (or groove in the up/down mechanical stop) on the shaft faces toward the tip of Arm #2

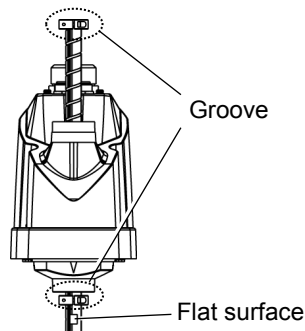
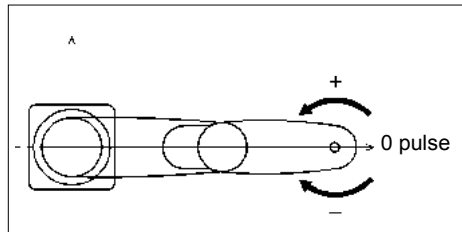

## (3)-3 Connect EPSON RC+ to the Manipulator.

Select a Manipulator to be calibrated. Input as below in the [Command Window] and execute it.

(This example uses “robot 1”.)

```
> robot 1
```

## (3)-4 Execute the absolute encoder initialization command.

Input one of the following commands to [Command Window] according to the joint being calibrated.

```
Joint #1: >EncReset 1
```

```
Joint #2: >EncReset 2
```

```
Joint #3: >EncReset 3
```

```
Joint #4: >EncReset 3, 4
```

## (3)-5 Reboot the Controller (Manipulator).

Select EPSON RC+ menu-[Tools]-[Controller] and click the <Reset Controller> button.

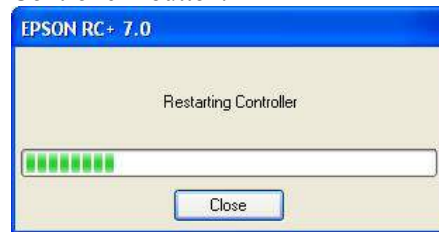

\* This window will be disappeared when the Controller starts up.

## 4. Rough Calibration

## (4)-1 Execute the following command from the menu-[Tools]-[Command Window].

```
>calpls 0,0,0,0
```

\* Manipulator does not move.

## (4)-2 Execute one of the following commands according to the joint you want to calibrate from the menu-[Tool]-[Command Window].

```
Joint #1 >calib 1
```

```
Joint #2 >calib 2
```

```
Joint #3 >calib 3
```

```
Joint #4 >calib 3, 4
```

## 5. Calibration (Accurate Positioning)

## (5)-1 Turn ON the motors from the EPSON RC+ menu -[Tools]-[Robot Manager]-[Control Panel].

## (5)-2 Click the &lt;Free All&gt; button to free all joints from servo control. Now, you can move arms by hands.

(5)-3 Move the Manipulator by hand to a rough position/posture of the calibration point data.

(5)-4 Create the data from the calibration point data.

Enter and execute the following command in [Command Window].

(In this example, P1 is used as the calibration point data.)

```
> Calpls Ppls (P1, 1) , Ppls (P1, 2) , Ppls (P1, 3) , Ppls (P1, 4)
```

(5)-5 Move the joint to the specified point using a motion command.

For example, when the specified point data is “P1”,

execute “Jump P1:Z(0)” from [Jog & Teach].

\* The joint NOT being calibrated moves to the original position.

(5)-6 Accurately align the joint\* being calibrated to the specified point using jog commands.

\* You must move Joint #3 and #4 to the position when calibrating Joint #4.

Select the jog mode [Joint] from [Jog & Teach] to execute the jog motion.

(5)-7 Execute the calibration.

Enter and execute one of the following commands in [Command Window] according to the joint being calibrated.

```
Joint #1: >Calib 1  
Joint #2: >Calib 2  
Joint #3: >Calib 3  
Joint #4: >Calib 3, 4
```

## 6. Accuracy Testing

(6)-1 Move the Manipulator to another point to confirm that it moves to the same position.

If it does not move to the same position, re-calibrate using another point.

You must set the point again if reproducibility cannot be assured through calibration.

## 17. Restrictions

For T series manipulator, there are commands with restrictions or may cause an error if executing. However, error does not occur when building a program.

Also, some functions have restrictions.

### 17.1 Commands Cannot Use

The following commands/ functions are not available.

<b>AbortMotion</b>	Aborts a motion command and puts the running task in error status.
<b>Toff</b>	Turns off execution line display on the LCD.
<b>Ton</b>	Specifies a task which shows an execution line on the LCD.
<b>ShutDown</b>	Shuts down EPSON RC+ and optionally shuts down or restarts Windows.
<b>WindowsStatus</b>	Returns the Windows startup status.

### 17.2 Commands Cause Motion Error If Specifying RS-232C

If specifying RS-232C port of the controller, the following commands/ functions cause motion error.

<b>Input #</b>	Allows string or numeric data to be received from a file, communications port, or database and stored in one or more variables.
<b>Print #</b>	Outputs data to the specified file, communications port, database, or device.
<b>Line Input #</b>	Reads data of one line from a file, communication port, database, or the device.
<b>Lof</b>	Checks whether the specified RS-232 or TCP/IP port has any lines of data in its buffer.
<b>Read</b>	Reads characters from a file or communications port.
<b>ReadBin</b>	Reads binary data from a file or communications port.
<b>Write</b>	Writes characters to a file or communication port without end of line terminator.
<b>WriteBin</b>	Writes binary data to a file or communications port.

## 17.3 Commands Cause Error

### 17.3.1 6-axis Robot Command

If executing the 6-axis robot command, motion error occurs.

### 17.3.2 Conveyor Tracking Commands

If executing conveyor tracking commands/functions, motion error occurs.

Cnv_AbortTrack	Aborts tracking motion to a conveyor queue point.
Cnv_Accel Function	Returns acceleration and deceleration for the conveyor
Cnv_Accel	Sets acceleration and deceleration for the conveyor
Cnv_Downstream Function	Returns the downstream limit for the specified conveyor.
Cnv_Downstream	Sets the downstream limit for the specified conveyor.
Cnv_Fine Function	Returns the current Cnv_Fine setting.
Cnv_Fine	Sets the value of Cnv_Fine for one conveyor.
Cnv_Flag Function	Returns the tracking state of the robot
Cnv_Mode Function	Returns the setting mode value of the conveyor
Cnv_Mode	Sets the setting mode value of the conveyor
Cnv_Name\$ Function	Returns the name of the specified conveyor.
Cnv_Number Function	Returns the number of a conveyor specified by name.
Cnv_OffsetAngle	Sets the offset value for the conveyor queue data.
Cnv_OffsetAngle Function	Returns the offset value of the conveyor queue data.
Cnv_Point Function	Returns a robot point in the specified conveyor's coordinate system derived from sensor coordinates.
Cnv_PosErr Function	Returns deviation in current tracking position compared to tracking target.
Cnv_Pulse Function	Returns the current position of a conveyor in pulses.
Cnv_QueueAdd	Adds a robot point to a conveyor queue.
Cnv_QueueGet Function	Returns a point from the specified conveyor's queue.
Cnv_QueueLen Function	Returns the number of items in the specified conveyor's queue.
Cnv_QueueList	Displays a list of items in the specified conveyor's queue.
Cnv_QueueMove	Moves data from upstream conveyor queue to downstream conveyor queue.
Cnv_QueueReject	Sets and displays the queue reject distance for a conveyor.
Cnv_QueueReject Function	Returns the current part reject distance for a conveyor.
Cnv_QueueRemove	Removes items from a conveyor queue.
Cnv_QueueUserData	Sets and displays user data associated with a queue entry.
Cnv_QueueUserData Function	Returns the user data value associated with an item in a conveyor queue.
Cnv_RobotConveyor Function	Returns the conveyor being tracked by a robot.
Cnv_Speed Function	Returns the current speed of a conveyor.
Cnv_Trigger	Latches current conveyor position for the next Cnv_QueueAdd statement.
Cnv_Upstream Function	Returns the upstream limit for the specified conveyor.
Cnv_Upstream	Sets the upstream limit for the specified conveyor.

### 17.3.3 PG Commands

If executing PG commands, motion error occurs.

PG_FastStop	Stops the PG axes immediately.
PG_LSpeed	Sets the pulse speed of the time when the PG axis starts accelerating and finishes decelerating.
PG_Scan	Starts the continuous spinning motion of the PG robot axes.
PG_SlowStop	Stops slowly the PG axis spinning continuously.

### 17.3.4 R-I/O Commands

If executing R-I/O commands/functions, motion error occurs.

LatchEnable	Enable/Disable the latch function for the robot position by the R-I/O input.
LatchState Function	Returns the latch state of robot position using the R-I/O.
LatchPos Function	Returns the robot position latched using the R-I/O input signal.
SetLatch	Sets the latch function of the robot position using the R-I/O input.

### 17.3.5 Force Sensing Commands

If executing force sensing commands/functions, motion error occurs.

Force_Calibrate	Sets zero offsets for all axes for the current force sensor.
Force_ClearTrigger	Clears all trigger conditions for the current force sensor.
Force_GetForces	Returns the forces and torques for all force sensor axes in an array.
Force_GetForce Function	Returns the force for a specified axis.
Force_Sensor	Sets the current force sensor for the current task.
Force_Sensor Function	Returns the current force sensor for the current task.
Force_SetTrigger	Sets the force trigger for the Till command.

### 17.3.6 Other (FineDist)

You cannot use the command: FineDist

Robot determines the position by set value of Fine even if using FineDist.

Fine	Specifies and displays the positioning error limits. (Unit: pulse)
FineDist	Specifies and displays the positioning error limits (Unit: mm)

### 17.3.7 Other (HealthCalcPeriod)

You cannot use the command: HealthCalcPeriod

A period of parts consumption commands information to calculate “remaining months” is one day and unable to change.

HealthCalcPeriod	Set the calculation period of parts consumption commands.
HealthCalcPeriod Function	Returns the calculation period of parts consumption commands.

### 17.3.8 Other (ChDisk)

You cannot specify USB option to the command: ChDisk.

## 17.4 Restrictions of Functions

Some of the following functions are not available.

### 17.4.1 TP3

You cannot use build of the program. An error occurs to finish the program if executing it. Other functions are available.

### 17.4.2 Loop Processing

If the created robot control program is consisted of the multi-tasking and also there are some task with infinite loop, the system may become unstable and the connection with EPSON RC+ is disconnected.

The controller detects infinite loop tasks. If the possibilities to affect the system are detected, the following error occurs and stops the program.

If the error occurs, modify the program and make sure not to set infinite loop.

Error code : 2556

Error message : An excessive loop was detected.  
Please reduce the number of looped tasks or set Wait

Do not perform any processing such as infinite loop or any other similar processing as much as possible.

Execute wait command or similar command in the loop processing and avoid occupying the CPU if performing calculation which required loop or waiting for I/O signals.

There is no problem if executing commands with Wait in the loop such as Wait command, robot operating command, Print command, and NetWait command.

NOTE: About infinite loop

Infinite loop is when commands are created only with command without Wait in the loop such as operation instruction, assignment command, and I/O check command.

Example 1: Turns ON output port "2" when Input port "0" turned ON

Example of program that may cause errors

```
Do
  If Sw(0) = On Then
    On(2)
  Exit Do
EndIf
Loop
```

Correction example

```
Wait Sw(0) = On
On(2)
```



Example 2: When performing the large amount of calculation with a loop structure.

Example of program that may cause errors

```
For i = 0 To 10000
  For j = 0 To 10000
    a = a + 1
  Next
Next
```

Correction example

```
For i = 0 To 10000
  For j = 0 To 10000
    a = a + 1
  Next
  Wait 0.01      ' Execute Wait to avoid occupying the CPU
Next
```

### 17.4.3 Camera Searching by CV1/CV2

You may not be able to use Camera searching by T series Manipulator if CV1/CV2 is used and the following two conditions are fulfilled.

- When connecting PC and T series Manipulator by USB connection
- When the configuration of default gateway of T series Manipulator is None, or "0.0.0.0".

Type IP address for CV1/ CV2 manually when you cannot use Camera researching.

For more details of Camera researching, refer to the following.

Vision Guide 7.0 Hardware & Setup

*Setup: 2.3.2 CV1/CV2 Camera Configuration*

### 17.4.4 Restore the Data of Backup Controller Function

Backup controller function that acquired by virtual controller cannot be restored to T series Manipulator.

NOTE : Backup controller function that acquired by actual equipment can be restored to T series Manipulator.

## 18. Error Code Table

For error code, refer to the following manual.

*EPSON RC+7.0 SPEL+ Language Reference SPEL+ Error Messages*

## 19. Maintenance Parts List

### \*1 Reduction Gear Unit

A reduction gear unit consists of the following three parts. When replacing the reduction gear unit, be sure to always replace the waveform generator, flexspline, and circular spline all together as one set.

#### Waveform generator

This waveform generator consists of an ellipsoidal cam with ball bearings on its outer circumference.

The inner ring of bearings is secured to the cam, while the outer ring is capable of flexible deformation through the ball bearings.

#### Flexspline

A thin, elastic, cup-shaped metal body with gear teeth around the outer circumference of the opening.

#### Circular spline

A rigid, ring-shaped body with gear teeth on the inner circumference.

The circular spline has two more teeth than the flexspline does.

Splines are greased. Be careful not to let grease adhere to clothes.

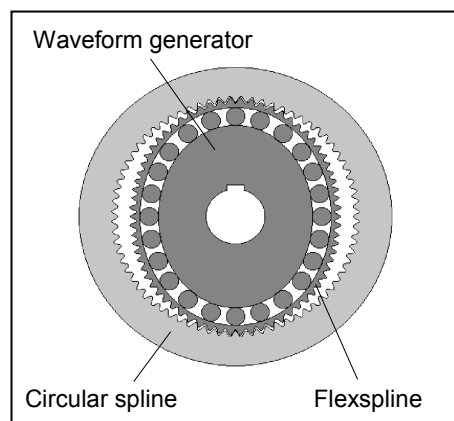

### \*2 Regarding purchase of grease

Due to the chemicals regulations of individual countries (the UN GHS), we are requesting our customers to purchase the grease required for maintenance from the manufacturers listed in the table below as of April 2015. Regarding purchase of the grease, please contact the following manufacturers. If there is anything unclear, please contact our suppliers.

Product name	Manufacturer	URL
THK AFB-LF Grease	THK CO., LTD.	<a href="http://www.thk.com/">http://www.thk.com/</a>
Harmonic Grease SK-1A Harmonic Grease SK-2	Harmonic Drive Systems Inc.	<a href="http://www.harmonicdrive.net/">http://www.harmonicdrive.net/</a>

### \*3 Overhaul

As a rough indication, perform the overhaul (parts replacement) before reaching 20,000 operation hours of the Manipulator. The operation hours can be checked in [Controller Status Viewer] dialog-[Motor On Hours].

For details, refer to *Maintenance 2.2 Overhaul (Parts Replacement)*.

## 19.1 T3

Part Name		Code	Note	Reference: Maintenance	Overhaul *3
Cable Duct Unit		2182565		8.1	
Motor Unit	Joint #1	2182560	200 W	9.1	✓
	Joint #2,3	2182562	100 W	10.1, 11.1	✓
	Joint #4	2182669	100 W	12.1	✓
Reduction Gear Unit *1	Joint #1	1718303		9.2	✓
	Joint #2	1718304		10.2	✓
O-Ring	Joint #1	1213266	Between reduction gear unit and Arm #1	9.2	
		1653819	Between reduction gear unit and Flange		
		1709549	Between motor and Flange		
	Joint #2	1213266	Between reduction gear unit and Arm #1	10.2	
		1653819	Between reduction gear unit and Arm #2		
Timing Belt	Joint #3	1554773	Z	11.2	✓
	Joint #4	1709608	U	12.2	✓
Solenoid Brake Unit		2182694	Z-axis	11.3	✓
Brake Release Switch		2167711		-	
Ball Screw Spline (150st)		1718877		13.2	✓
Lithium Battery		2113554		14.2	
CPU/DPB Board		2182747		14.1	
Power Board		2182749		14.4.2	
LED Lamp Unit		2182673		15	
Grease *2	Ball Screw Spline: AFB	-	For purchasing grease, please contact the supplier in your region.	13	
	Reduction Gear Unit: SK-2			9.2, 10.2	
Arm Cover		1718126	Arm Top Cover (White)	7.1	
Under Cover		1625284	Arm Bottom Cover (White)	7.2	
SD Card		2182748		14.3	
Air Filter		1713720		14.4.1	
TP Plug		2171258		-	

**19.2 T6**

Part Name		Code	Note	Reference: Maintenance	Overhaul *3
Cable Duct Unit		2190924		8.1	
Motor Unit	Joint #1	2190962	300 W	9.1	✓
	Joint #2	2190963	200 W	10.1	✓
	Joint #3	2182601	100 W	11.1	✓
	Joint #4	2182670	100 W	12.1	✓
Reduction Gear Unit *1	Joint #1	1750570		9.2	✓
	Joint #2	1750571		10.2	✓
O-Ring	Joint #1	1510528	Between reduction gear unit and Arm #1	9.2	
		1650901	Between reduction gear unit and Flange		
		1213266	Between flanges		
		1520371	Between motor and Flange		
	Joint #2	1213267	Between reduction gear unit and Arm #1	10.2	
		1653181	Between reduction gear unit and Arm #2		
Timing Belt	Joint #3	1563316	Z	11.2	✓
	Joint #4	1674797	U1	12.2	✓
		1674798	U2		
Solenoid Brake Unit		1750573	Z-axis	11.3	✓
Brake Release Switch		2167711		-	
Ball Screw Spline (200st)		1750572		13.2	✓
Lithium Battery		2113554		14.2	
CPU/DPB Board		2191143		14.1	
Power Board		2188638		14.4.2	
AMP Board		2189027		-	
LED Lamp Unit		2182673		15	
Grease *2	Ball Screw Spline: AFB	-	For purchasing grease, please contact the supplier in your region.	13	
	Reduction Gear Unit: SK-2			9.2, 10.2	
Arm Cover		1750683	Arm Top Cover (White)	7.1	
Under Cover		1737896	Arm Bottom Cover (White)	7.2	
SD Card		2182748		14.3	
Air Filter		1743656		14.4.1	
TP Plug		2171258		-	

## Appendix A: Open Source Software License for T series

- (1) The T series product includes open source software programs listed in Section (6) according to the license terms of each open source software program.
- (2) We provide the source code of the Open Source Programs (each is defined in Section (6)) until five (5) years after the discontinuation of same model of this option product. If you desire to receive the source code above, please contact the "SUPPLIER" in the first pages of the *Robot System Safety and Installation* manual. You shall comply with the license terms of each open source software program.
- (3) The open source software programs are WITHOUT ANY WARRANTY; without even the implied warranty of MERCHANTABILITY AND FITNESS FOR A PARTICULAR PURPOSE. See the license agreements of each open source software program for more details, which are described on Section (7).
- (4) OpenSSL toolkit  
The T series product includes software developed by the OpenSSL project for use in the OpenSSL Toolkit (<http://www.openssl.org/>).  
This product includes cryptographic software written by Eric Young (eay@cryptsoft.com).
- (5) The license terms of each open source software program are described on Section (7).
- (6) The list of open source software programs which the T series product includes are as follows.

bash	dash	libc-bin	libc6
libcomerr2	libdevmapper 1.02.1	libgcc1	libstdc++6
libudev1	login	Logrotate	makedev
mount	mountall	net-tools	netbase
rsyslog	ssh	sudo	tzdata
ubuntu-minimal	udev	Linux	Xenomai

(7) For the each open source license, please refer to the URLs as follows.

bash	<a href="http://tiswww.case.edu/php/chet/bash/bashtop.html">http://tiswww.case.edu/php/chet/bash/bashtop.html</a>
dash	<a href="http://packages.ubuntu.com/ja/precise/dash">http://packages.ubuntu.com/ja/precise/dash</a>
libc-bin	<a href="http://www.eglibc.org/home">http://www.eglibc.org/home</a>
libc6	<a href="http://www.eglibc.org/home">http://www.eglibc.org/home</a>
libcomerr2	<a href="http://packages.ubuntu.com/ja/precise/libcomerr2">http://packages.ubuntu.com/ja/precise/libcomerr2</a>
libdevmapper1.02.1	<a href="ftp://sources.redhat.com/pub/lvm2/">ftp://sources.redhat.com/pub/lvm2/</a>
libgcc1	<a href="ftp://gcc.gnu.org/pub/gcc/releases/">ftp://gcc.gnu.org/pub/gcc/releases/</a>
libstdc++6	<a href="ftp://gcc.gnu.org/pub/gcc/releases/">ftp://gcc.gnu.org/pub/gcc/releases/</a>
libudev0	<a href="http://packages.ubuntu.com/ja/precise/libudev0">http://packages.ubuntu.com/ja/precise/libudev0</a>
login	<a href="http://packages.ubuntu.com/ja/precise/login">http://packages.ubuntu.com/ja/precise/login</a>
logrotate	<a href="https://fedorahosted.org/logrotate/">https://fedorahosted.org/logrotate/</a>
makedev	<a href="ftp.redhat.com">ftp.redhat.com</a>
mount	<a href="ftp://ftp.us.kernel.org/pub/linux/utils/util-linux-ng/">ftp://ftp.us.kernel.org/pub/linux/utils/util-linux-ng/</a>
mountall	<a href="http://packages.ubuntu.com/ja/precise/mountall">http://packages.ubuntu.com/ja/precise/mountall</a>
net-tools	<a href="https://developer.berlios.de/projects/net-tools/">https://developer.berlios.de/projects/net-tools/</a>
netbase	<a href="http://packages.ubuntu.com/ja/precise/netbase">http://packages.ubuntu.com/ja/precise/netbase</a>
rsyslog	<a href="http://www.rsyslog.com">http://www.rsyslog.com</a>
ssh	<a href="http://www.openssh.com/ftp.html">http://www.openssh.com/ftp.html</a>
sudo	<a href="http://www.sudo.ws/">http://www.sudo.ws/</a>
tzdata	<a href="http://www.iana.org/time-zones">http://www.iana.org/time-zones</a>
ubuntu-minimal	<a href="http://packages.ubuntu.com/ja/precise/ubuntu-minimal">http://packages.ubuntu.com/ja/precise/ubuntu-minimal</a>
udev	<a href="http://packages.ubuntu.com/ja/precise/udev">http://packages.ubuntu.com/ja/precise/udev</a>
Linux	<a href="http://www.kernel.org/">http://www.kernel.org/</a>
Xenomai	<a href="http://www.xenomai.org/">http://www.xenomai.org/</a>