

Manual Version 2.1
Software Version 2.7.1

Doosan Robot

M0609 | M0617 | M1013 | M1509
H2017 | H2515

Installation Manual



Preface	10
Copyright	10
Open Source Software License Information (OSS)	10
1. Safety.....	11
1.1 Manual Indication Conventions	11
1.2 Safety Symbols	12
1.3 General Instructions	13
1.4 Product Usage	15
1.5 Risk Assessment.....	16
1.6 Potential Risks	18
1.7 Validity and Responsibility	19
2. Product Introduction.....	20
2.1 Component Check	20
2.2 Names and Functions.....	21
2.2.1 Manipulator.....	21
2.2.2 Controller.....	23
2.2.3 Teach pendant.....	24
2.3 System Configuration.....	25
2.4 Product Specifications, General.....	26
2.5 Robot Specifications.....	27

2.5.1	Basic Specification.....	27
2.5.2	Axis Specification.....	28
2.5.3	Robot operating space.....	29
2.5.4	Max. Payload within operating space.....	41
2.5.5	Tool Center Point (TCP).....	44
2.6	Nameplate and Label	45
3.	Installation	46
3.1	Cautions during Installation	46
3.2	Installation Environment	47
3.2.1	Installation Location Check.....	47
3.2.2	Robot Work Area Check.....	48
3.3	Hardware Installation	49
3.3.1	Securing the Robot.....	49
3.3.2	Connecting the Robot and Tool.....	51
3.3.3	Connecting the Manipulator and Controller.....	52
3.3.4	Connecting the Controller and Teach Pendant.....	54
3.3.5	Routing of Manipulator Cable and Teach Pendant Cable.....	56
3.3.6	Supplying Power to the Controller.....	57
4.	Interface	59
4.1	Flange I/O	59
4.1.1	Flange Digital Output Specifications.....	62

4.1.2	Flange Digital Input Specifications.....	63
4.2	Connecting Controller I/O	64
4.2.1	Setting the Terminal Block for Contact Input (TBSFT).....	65
4.2.2	Setting the Terminal Block for Safety Contact Output (TBSTO).....	66
4.2.3	Setting the Digital I/O Power Terminal (TBPWR).....	67
4.2.4	Setting the Configurable Digital I/O (TBC11 - 4, TBCO1 - 4).....	68
4.2.5	Setting Analog I/O Terminal (TBAIO).....	74
4.2.6	Setting Encoder Input Terminal (TBEN1, TBEN2).....	76
4.3	Network Connection	78
4.3.1	Connecting External Devices - Vision Sensor.....	78
4.3.2	Connecting External Device – DART Platform.....	80
4.3.3	ModbusTCP Slave Setup.....	81
4.3.4	Expanded Protocol - PROFINET IO Device (PNIO device) Setup.....	82
4.3.5	Expanded Protocol - EtherNet/IP Adapter (EIP adapter) Setup.....	83
4.3.6	Using Expanded Protocol.....	84
4.3.7	Using General Purpose Register (GPR).....	85
5.	Robot Mode and State	86
5.1	Manual Mode.....	86
5.2	Automatic Mode.....	87
5.3	Other Mode.....	88
5.4	State and Flange LED Color for Each Mode.....	89
6.	Safety Functions	91

6.1	Introduction	91
6.2	Safety-Rated Stop Function	92
6.2.1	Emergency Stop Function	93
6.2.2	Protective Stop	94
6.3	Safety Rated Monitoring Function	95
6.4	Safety-Rated I/O	97
7.	Transportation	98
7.1	Caution during Transportation	98
7.2	Pose for Robot Transportation	99
7.3	Package Specifications	100
8.	Maintenance	101
9.	Disposal and Environment	102
10.	Product Warranty and Responsibility	103
10.1	Scope of Warranty	103
10.2	Restrictions and Exceptions of Warranty	104
10.3	Transfer	105

11. Indemnification 106

Annex A System Specification 107

A.1 Manipulator 107

A.1.1 M0609 107

A.1.2 M1509 108

A.1.3 M1013 109

A.1.4 M0617 110

A.1.5 H2017 111

A.1.6 H2515 112

A.2 Controller 113

A.2.1 CS-01 (AC Controller) 113

A.2.2 CS-02 (DC Controller) 114

A.2.3 CS-01P (AC Controller) 115

A.3 Teach pendant 116

A.3.1 TP-01 116

A.4 DART Platform Installation Requirement (minimum, recommended) ... 117

Annex B Declaration and Certification 118

B.1 Europe Declaration of Incorporation (Original) 118

B.2 Europe Machinery Directive Attestation of Conformity 119

B.3 Europe EMC Directive Attestation of Conformity 121

B.4 U.S. NRTL Certification (U.S., CANADA) 122

B.5 Functional Safety Certification.....	124
B.6 Voluntary Safety Confirmation Declaration (KCs)	125

Annex C Stop Distance and Stop Time131

C.1 Measurement Methods and Conditions.....	131
C.1.1 General Information.....	131
C.1.2 Stop Category:.....	132
C.1.3 Measurement Poses and Conditions.....	133
C.2 M1013	135
C.2.1 Stop Category 1.....	135
C.2.2 Stop Category 0.....	138
C.3 M0609	139
C.3.1 Stop Category 1.....	139
C.3.2 Stop Category 0.....	142
C.4 M0617	143
C.4.1 Stop Category 1.....	143
C.4.2 Stop Category 0.....	146
C.5 M1509	147
C.5.1 Stop Category 1.....	147
C.5.2 Stop Category 0.....	150
C.6 H2017	151
C.6.1 Stop Category 1.....	151
C.6.2 Stop Category 0.....	154
C.7 H2515.....	155

C.7.1 Stop Category 1	155
C.7.2 Stop Category 0	158

Annex D DC Controller (CS-02)..... 159

D.1 Product Introduction.....	159
D.1.1 Names and Functions.....	159
D.1.2 System Configuration.....	160
D.1.3 Nameplate and Label.....	161
D.2 Installation	162
D.2.1 Cautions during Installation.....	162
D.2.2 Installation Environment.....	163
D.2.3 Hardware Installation.....	164
D.3 Interface.....	172
D.3.1 Connecting Controller I/O.....	172
D.3.2 Network Connection.....	173

Annex E IP Steel Controller (CS-01P) 174

E.1 Product Introduction.....	174
E.1.1 Names and Functions.....	174
E.1.2 System Configuration.....	175
E.1.3 Nameplate and Label.....	176
E.2 Installation.....	177
E.2.1 Cautions during Installation.....	177

E.2.2 Installation Environment.....	178
E.2.3 Hardware Installation.....	179

Annex F H-Series Handling Guide.....186

Preface

Thank you for choosing this Doosan Robotics product. Before installing the product, please read through this manual and follow the instructions for each installation process provided in this manual. The contents of this manual are current as of the date this manual was written, and product-related information may be modified without prior notification to the user.

Copyright

The copyright and intellectual property rights of the contents of this manual are held by Doosan Robotics. It is therefore prohibited to use, copy, or distribute the contents without written approval from Doosan Robotics. In the event of abuse or modification of the patent rights, the user will be solely responsible for the consequences.

While the information in this manual is reliable, Doosan Robotics will not be held accountable for any damage that occurs due to errors or typos. The contents of this manual may be modified according to product improvement without prior notification.

For details of updated manuals, refer to the Doosan Robotics website (www.doosanrobotics.com).

© 2021 Doosan Robotics Inc., All rights reserved

Open Source Software License Information (OSS)

The software installed in this product was developed based on free/open source software.

Details about the free/open source software license can be found on the OSS use page on the Doosan Robotics website (www.doosanrobotics.com/kr/oss/license).





For related inquiries, contact the Marketing Department of Doosan Robotics (marketing.robotics@doosan.com).

1. Safety

This chapter provides safety information the user must be aware of before installing or operating the robot. All robots have risks of high voltage, electricity and collision. Therefore, in order to minimize the risk of injuries and mechanical damage, one must observe the basic safety cautions while operating the robot and using related parts. To protect user safety and prevent property loss, make sure to read and follow the instructions carefully. The contents of the manual and specifications of the product may change for product and performance improvements.







1.1 Manual Indication Conventions

To communicate safety precautions related to the use of the product, the following symbols are indicated in this manual.

Symbol	Name	Description
	Danger	Failure to observe instructions with this symbol may result in serious accidents that could result in death or serious injury to the operator.
	Warning	Failure to observe instructions with this symbol may result in serious accidents that could result in death or serious injury to the operator.
	Caution	Failure to observe instructions with this symbol may result in product damage or cause injury to the operator.
	Note	This is additional information to help the user.

1.2 Safety Symbols

Among the symbols used in this manual, symbols related to user safety are as follows:

Symbol	Description
 Danger	This symbol means that immediate hazards can occur due to electrical conditions such as high voltage. Failure to observe instructions with this symbol may result in serious accidents that could result in death or serious injury to the operator.
 Danger	This symbol means that immediate hazards can occur. Failure to observe instructions with this symbol may result in serious accidents that could result in death or serious injury to the operator.
 Warning	This symbol means that potentially dangerous situations can occur due to electrical conditions such as high voltage. Failure to observe instructions with this symbol may result in serious accidents that may cause serious injury to the operator.
 Warning	This symbol means potentially dangerous situations can occur. Failure to observe instructions with this symbol may result in serious accidents that may cause serious injury to the operator.
 Caution	This symbol means dangerous situations can occur due to overheating. Failure to observe instructions with this symbol may result in serious accidents that may cause serious injury to the operator.
 Caution	The product may become damaged or the operator may suffer injury.

1.3 General Instructions

This chapter describes general danger and warning items related to operating the robot.



Warning

- If the robot is installed with electrical devices, install the robot referring to the Installation Manual.



Warning

- If a device is installed on the tool during robot installation, make sure to use appropriate bolts.
- Suitable safety measures, such as safety fences, must be implemented to protect the staff and robot during installation.
- Do not wear loose-fitting clothes or accessories when operating the robot. If one's hair is long, make sure to tie up the hair to prevent it from getting caught between robot joints.
- Never operate a damaged robot.
- Take caution of the robot's movement when using the teaching pendant.
- If the teaching pendant warns the user of a critical error, immediately engage the emergency stop switch of the robot, identify the cause of the error, resolve the error and then resume robot operation. If the critical error cannot be resolved, contact the sales agent or robot supplier.
- Make sure to connect safety protection equipment with a safety interface. If such equipment is connected to a general interface, the integrity of safety functions may not be guaranteed.
- Make sure to become completely familiar with the robot user manual prior to operating the robot.
- If the robot collides with an external object, a significant impact may be generated. The impact the robot receives is proportionate to the kinetic energy, so higher speeds and high payload can generate large impacts. Make sure to maintain a safe speed and payload during operation in collaborative spaces.
- Direct teaching must only be performed in safe environments. Do not operate the robot if there are sharp edges or jamming near the tool and its surroundings.
- Before performing direct teaching, make sure accurate inputs (tool length, weight, center of gravity) are made. If inputs are different from the tool specification, direct teaching error or malfunctioning can occur.
- To ensure user safety, joints may operate at a certain speed or higher, or the maximum speed of the TCP may be limited during direct teaching. If the limit is exceeded, the protective stop function activates.
- Enable/disable the direct teaching function when the robot has completely stopped. If the direct teaching function is enabled/disabled during robot operation, malfunctions may occur.
- If the robot axis must be rotated when the robot is not operated, it can be rotated at a torque

greater than 400 Nm.

- Modifying the robot without prior approval may cause critical breakdowns and accidents.



Caution

- Operating the robot and controller for an extended period of time generates heat. Do not touch the robot with bare hands after operating for an extended period of time. Before performing work that requires touching the robot, such as tool installation, leave the robot for more than 1 hour after turning off the power of the control unit to cool down the robot.



Caution

- Do not expose the robot to powerful magnetic fields. It may cause damage to the robot.
- Do not use the controller being laid. To avoid getting a hand caught in the door by accident, make sure to keep it upright while working with the door open.

1.4 Product Usage

This is an industrial product designed specifically for purposes of transferring and assembling objects by attaching components to products using tools, and it must be operated in the conditions specified in its specifications.

This product features special safety functions designed for the purpose of collaborating with human operators, and it operates with human operators without specific boundaries. Conduct work with the system only when all applications, including the tool, workpiece, boundary and other equipment, are confirmed to have no harm.

The following uses are considered inappropriate because they exceed the boundaries of the product's intended purpose. Doosan Robotics will not be held responsible for any damage and malfunctioning of the robot, property losses and injuries to users due to such inappropriate uses.

- Use in an environment with potential explosions
- Use in application related to medicine and human lives
- Use in transporting humans and animals
- Use without risk assessment
- Use in locations where performance and operation environment specifications are not met
- Use in environments with insufficient safety functions
- Use of the robot as a step to stand on
- Use in environments where electromagnetic waves are generated at levels greater than the IEC standard, such as welding

1.5 Risk Assessment

One of the most important aspects of a system integrator is risk assessment. Risk assessment is legally mandatory in most countries. In addition, safety assessment of robot installation changes according to the overall system integration method, so it is impossible to perform risk assessment solely with the robot.

In order to perform risk assessment, the administrator overseeing the overall system establishment must install and operate the robot according to ISO12100 and ISO10218-2. In addition, the administrator can refer to the technical specification, ISO/TS 15066.

Risk assessment must consider the overall work process in terms of the overall life cycle of the robot application. Key objectives of risk assessment are as follows:

- Robot setting and work teaching for robot operation
- Troubleshooting and maintenance
- Proper robot installation

Before supplying power to the robot arm, make sure to perform a risk assessment. Setting appropriate safety settings and identifying the need for additional emergency stop buttons and other protective measures are parts of risk assessment.

Identifying appropriate safety settings is a critical aspect of developing a collaborative robot application. For more information, refer to the corresponding chapter of the manual.

Some safety functions are designed specifically for collaborative robot applications. These functions can be set up through safety function settings, and they are optimized for responding to specific risks identified through the risk assessment performed by the integrator.

The safety functions of the collaborative robot can be set up in the safety setting menu, and they offer the following features:

- Force and power limitation: Limits the stopping force and pressure of the robot in case of collisions between the robot and a worker
- Momentum limitation: Limits the energy and impact load by reducing the speed of the robot when a collision between the robot and a worker occurs
- Joint position and TCP limitation: Limits robot movement to prevent moving towards specific body parts of users such as the neck or head
- TCP and tool pose limitation: Limits certain areas or characteristics of a tool and workpiece to minimize related risks (i.e., limits the movement of sharp edges of workpieces aimed at users)
- Speed limitation: Limits robot movement to stay at low speed in order to secure time for the user to avoid a collision before a collision between the robot and a worker occurs

Applying appropriate safety settings is considered to be the same as fixing the robot to a specific location and connecting it to a safety-related I/O. For example, setting password protection can prevent unauthorized safety setting changes by individuals not approved by the system integrator.

Key items to note when performing risk assessment of the collaborative robot application are as follows:

- Severity of individual potential collisions
- Probability of individual potential collision occurrence
- Probability of individual potential collision avoidance

If the robot is installed on a non-collaborative robot application that cannot sufficiently remove risks using its internal safety functions (e.g., use of dangerous tool), the system integrator must decide to install additional protection devices during risk assessment (e.g., use of protection devices capable of protecting the integrator during installation and programming).

1.6 Potential Risks

- Jamming fingers between the manipulator base and mount
- Jamming limbs between the Link 1 and Link 2 (between Joint 3 (J3) and Joint 4 (J4))
- Jamming limbs between Joint 1 and Joint 2 (J1 and J2) and Joint 5 and Joint 6 (J5 and J6)
- Penetration of skin by sharp edges or surfaces of the tool
- Penetration of skin by sharp edges or surfaces of objects in the operating space of the robot
- Contusion caused by robot movement
- Bone fracturing due to movement between heavy payload and hard surface
- Accidents that occur due to loosening of bolts securing the robot flange or tool
- Object falls from the tool due to inappropriate grip or sudden power shortage
- Accidents that occur due to mistaking an emergency stop button of different equipment
- Errors that occur due to unauthorized safety parameter modification

1.7 Validity and Responsibility

This manual does not provide information about the design, installation and operation methods of robot applications integrated with other system. In addition, this manual does not provide information that may influence the safety of the integrated system.

The system administrator must install the robot in a way that observes various safety requirements according to the related national standards and regulations. In addition, the staff in charge of integrating and managing the robot in a system must ensure that all related national safety legislation and regulations are observed. The entity or user of the final system in which the robot is integrated has the following responsibilities, and such responsibilities are not limited to the items listed below.

- Risk assessment of the system with the robot integrated
- Installation and removal of safety devices according to the outcome of the risk assessment performed
- Confirmation of whether the system is properly designed, set up and installed
- Establishment of system operation and instructions
- Management of suitable safety settings in the software
- Prevention of users modifying safety devices
- Validity check of design and installation of integrated system
- Indication of contact information or important notifications related to use and safety
- Provision of technical documents including various manuals
- Provision of information on standards and legislation applied: <http://www.doosanrobotics.com/>

Compliance with the safety requirements in this manual does not mean all risks can be prevented.

2. Product Introduction

2.1 Component Check

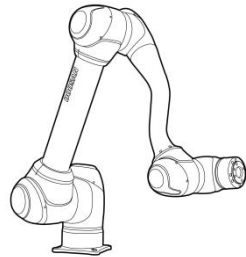

Manipulator

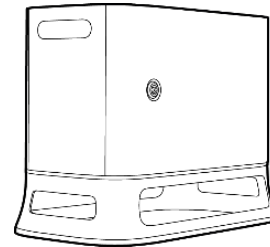

Controller (Option : Refer to Appendix)



Teach pendant

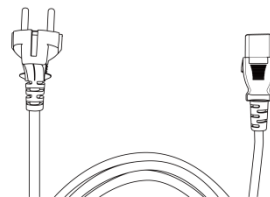

Controller power supply cable

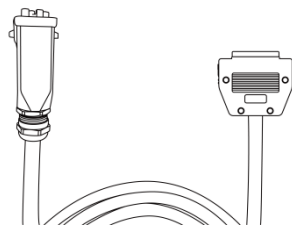

Manipulator connection cable

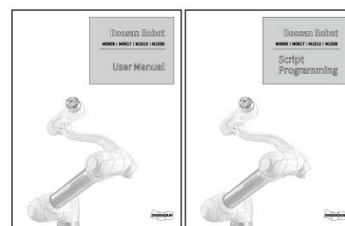

User manual / Quick guide

 **Note**

- Components may vary depending on the robot model.

2.2 Names and Functions

2.2.1 Manipulator

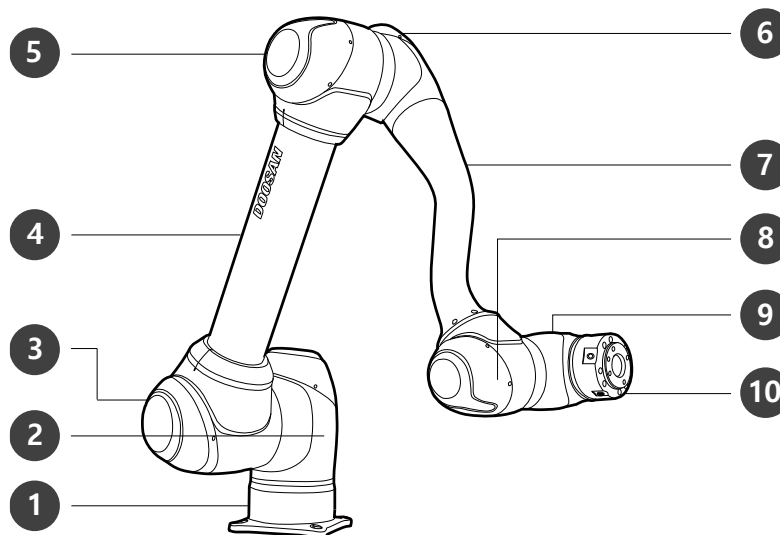

• Names of Parts

No.	Name	No.	Name
1	Base	6	J4
2	J1	7	Link2
3	J2	8	J5
4	Link1	9	J6
5	J3	10	Tool flange

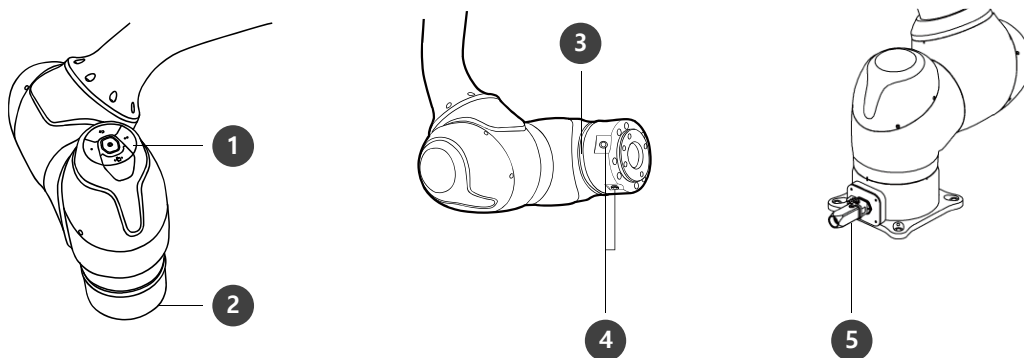

• Key Features

No.	Item	Description
1	Cockpit	[Option] Controller used for direct teaching and operation.
2	Tool flange	Area to install tools.
3	Flange LED	Displays the robot state with different colors. For more information about robot state, refer to the “ 5.4 State and Flange LED Color for Each Mode ” For H-Series, an additional LED is installed on the 1 axis to indicate the same status and color.
4	Flange I/O	I/O port for tool control. (Digital input 3ch, output 3ch)
5	Connector	Used for supplying power to and communication of the robot.

2.2.2 Controller

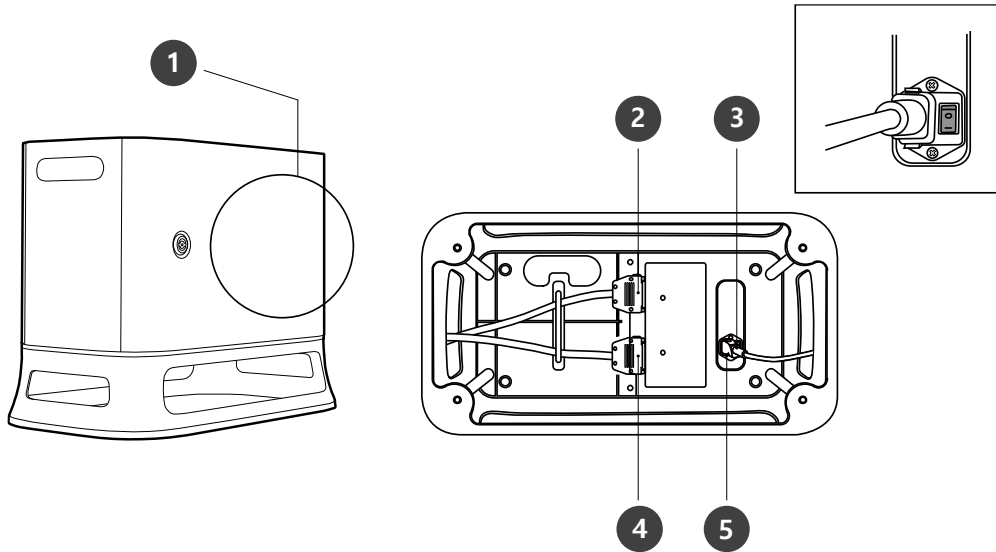

No.	Item	Description
1	I/O connection terminal (internal)	Used to connect the controller or peripherals.
2	Teach pendant cable connection terminal	Used to connect the teach pendant cable with the controller.
3	Power switch	Used to turn ON/OFF the main power of the controller.
4	Manipulator cable connection terminal	Used to connect the manipulator cable to the controller.
5	Power connection terminal	Used to connect the controller power supply.

 **Note**

- If you selected an optional controller, check the instructions in the appendix to connect cables.

2.2.3 Teach pendant

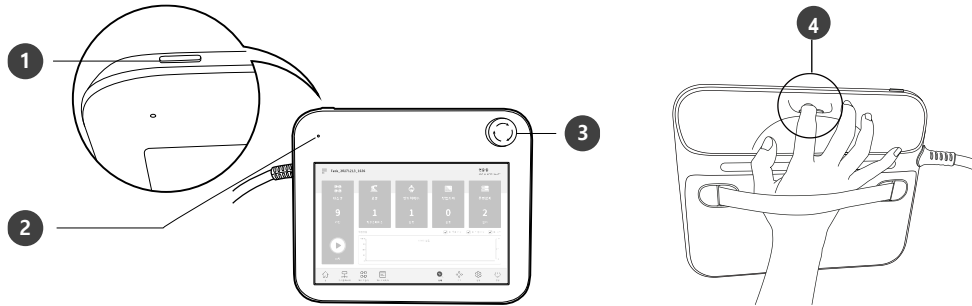

No.	Item	Description
1	Power button	Used to turn ON/OFF the main power of the teach pendant.
2	Power LED	Turns ON when power is supplied.
3	Emergency stop button	Press the button to stop robot operation in case of an emergency.
4	Hand guiding button	Press and hold the button to move the robot freely into a desired pose.

 **Note**

- If you need to protect and hold the Teach Pendant during work, you can use it more safely and easily with a soft cover supplied by Doosan Robotics.

2.3 System Configuration

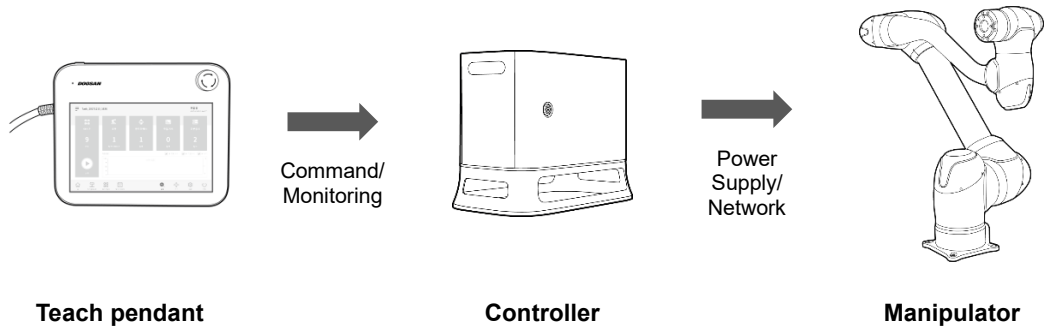

- **Teach pendant:** It is a device that manages the overall system, and it is capable of teaching the robot specific poses and setting manipulator and controller related settings.
- **Controller:** It controls the robot's movement according to the pose or movement set by the teach pendant. It features various I/O ports that allow the connection and use of various equipment and devices.
- **Manipulator:** It is an industrial collaborative robot that can perform transport or assembly tasks with various tools.

Note

- Refer to the robot system configurations of the M Series and H Series below.

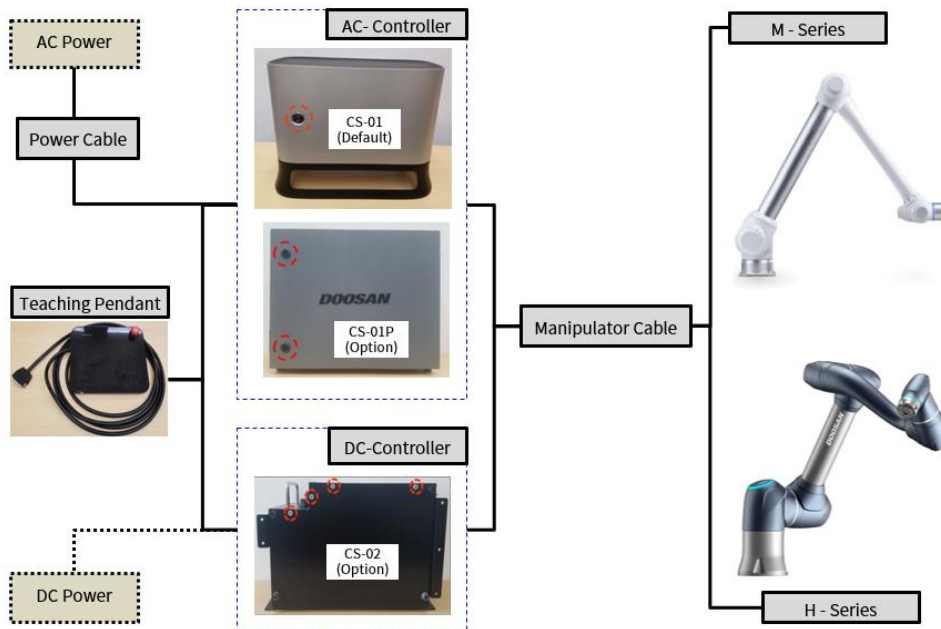

2.4 Product Specifications, General

M-Series	Technical Data
M0609	Refer to A.1.1 M0609
M0617	Refer to A.1.4 M0617
M1013	Refer to A.1.3 M1013
M1509	Refer to A.1.2 M1509

H-Series	Technical Data
H2017	Refer to A.1.5 H2017
H2515	Refer to A.1.6 H2515

2.5 Robot Specifications

2.5.1 Basic Specification

Model Name	M0609	M0617	M1013	M1509	H2017	H2515
Weight	27 kg	34 kg	33 kg	32 kg	74 kg	72 kg
Payload within Work Radius	6 kg	6 kg	10 kg	15 kg	20 kg	25 kg
Max. Work Radius	900 mm	1700 mm	1300 mm	900 mm	1700mm	1500mm
Number of Axes	6					
Max. TCP Speed	Over 1 m/s					
Position Repeatability (ISO 9283)	±0.1 mm (±0.03 mm)	±0.1 mm	±0.1 mm (±0.05 mm)	±0.1 mm (±0.03 mm)	±0.1 mm	
Protection Rating	IP 54					
Noise	< 65 dB					
Installation Direction	Floor / Wall / Ceiling				Floor Only	
Controller and Teaching Pendant	Doosan Controller & TP					
Vibration and Acceleration	10≤f< 57Hz - 0.075mm amplitude 57≤f≤150Hz - 1G					
Impact	Max Amplitude : 50m/s ² (5G) * Time :30ms , Pulse : 3 of 3 (X,Y,Z)					
Operating Temperature	0 °C ~45 °C (273K to 318K)					
Storage Temperature	-5 °C ~50 °C (268K to 323K)					
Humidity	20%~80%					

2.5.2 Axis Specification

Model Name	M0609	M0617	M1013	M1509	H2017	H2515
Operating Angle						
J1	±360° (TP:±360°)	±360° (TP:±360°)	±360° (TP:±360°)	±360° (TP:±360°)	±360° (TP:±360°)	±360° (TP:±360°)
J2	±360° (TP:±95°)	±360° (TP:±95°)	±360° (TP:±95°)	±360° (TP:±95°)	±TP125° (TP:±95°)	±TP125° (TP:±95°)
J3	±150° (TP:±125°)	±165° (TP:±145°)	±160° (TP:±135°)	±150° (TP:±125°)	±160° (TP:±135°)	±160° (TP:±135°)
J4	±360° (TP:±360°)	±360° (TP:±360°)	±360° (TP:±360°)	±360° (TP:±360°)	±360° (TP:±360°)	±360° (TP:±360°)
J5	±360° (TP:±135°)	±360° (TP:±135°)	±360° (TP:±135°)	±360° (TP:±135°)	±360° (TP:±135°)	±360° (TP:±135°)
J6	±360° (TP:±360°)	±360° (TP:±360°)	±360° (TP:±360°)	±360° (TP:±360°)	±360° (TP:±360°)	±360° (TP:±360°)

Max. Speed per Axis (rated payload operation)

J1	150 °/s	100 °/s	120 °/s	150 °/s	100 °/s	100 °/s
J2	150 °/s	100 °/s	120 °/s	150 °/s	80 °/s	80 °/s
J3	180 °/s	150 °/s	180 °/s	180 °/s	100 °/s	100 °/s
J4	225 °/s	225 °/s	225 °/s	225 °/s	180 °/s	180 °/s
J5	225 °/s	225 °/s	225 °/s	225 °/s	180 °/s	180 °/s
J6	225 °/s	225 °/s	225 °/s	225 °/s	180 °/s	180 °/s

2.5.3 Robot operating space

- M0609

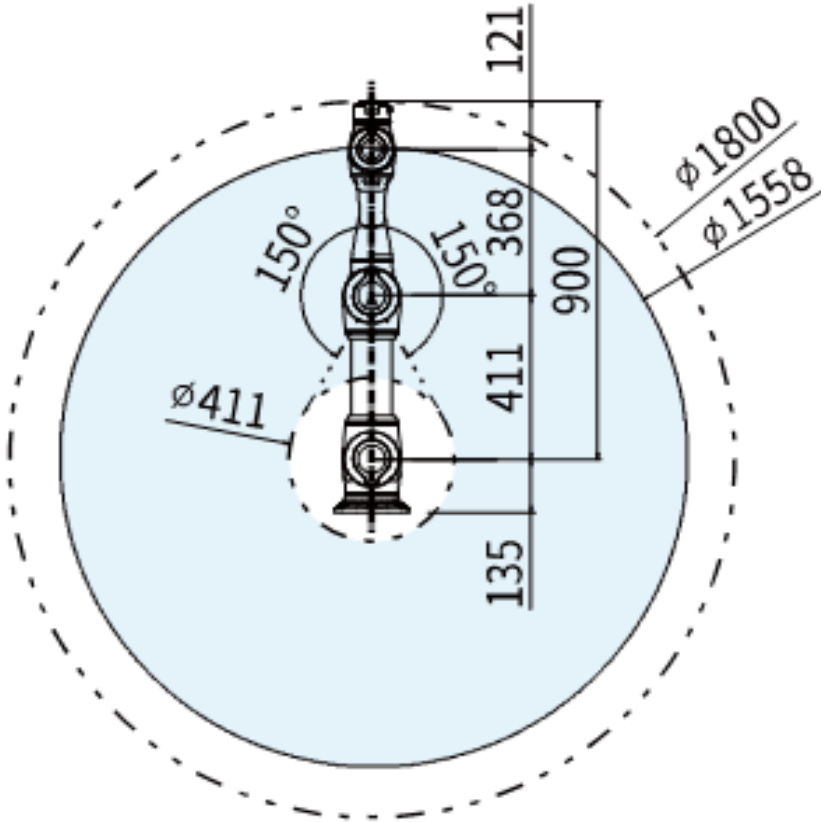

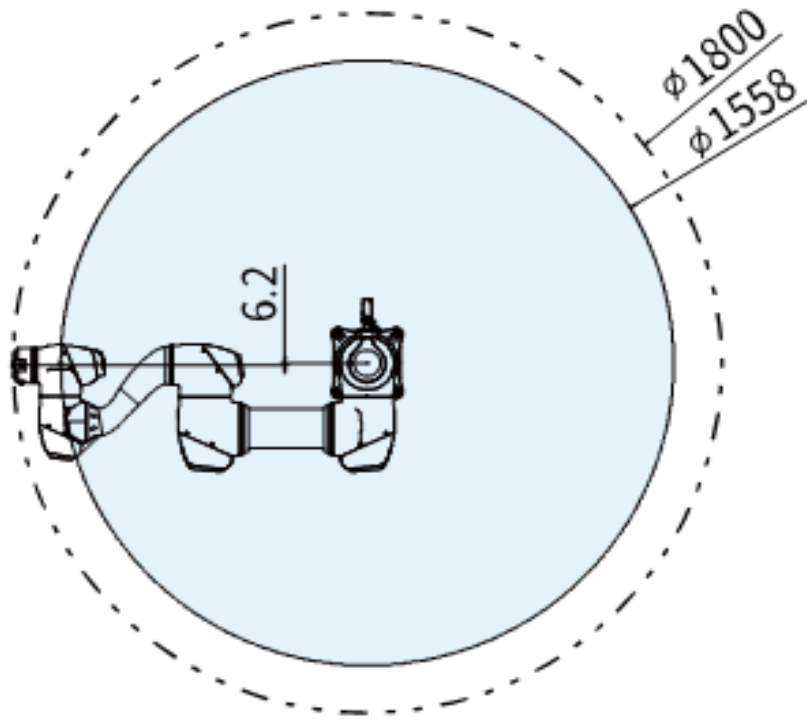

• M0617

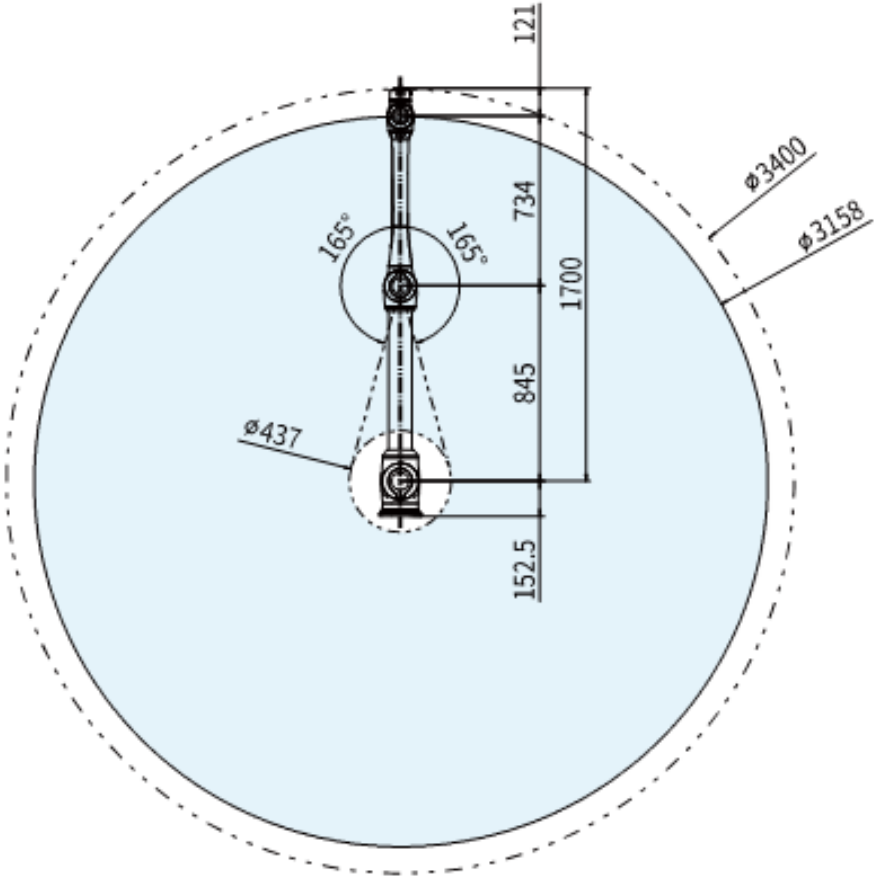

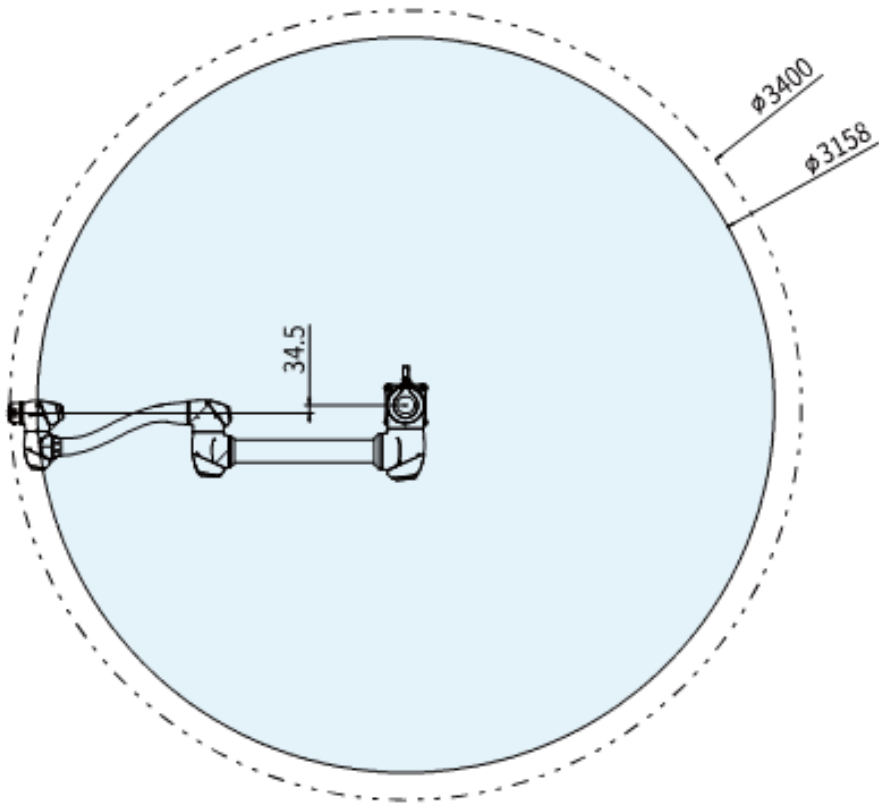

• M1013

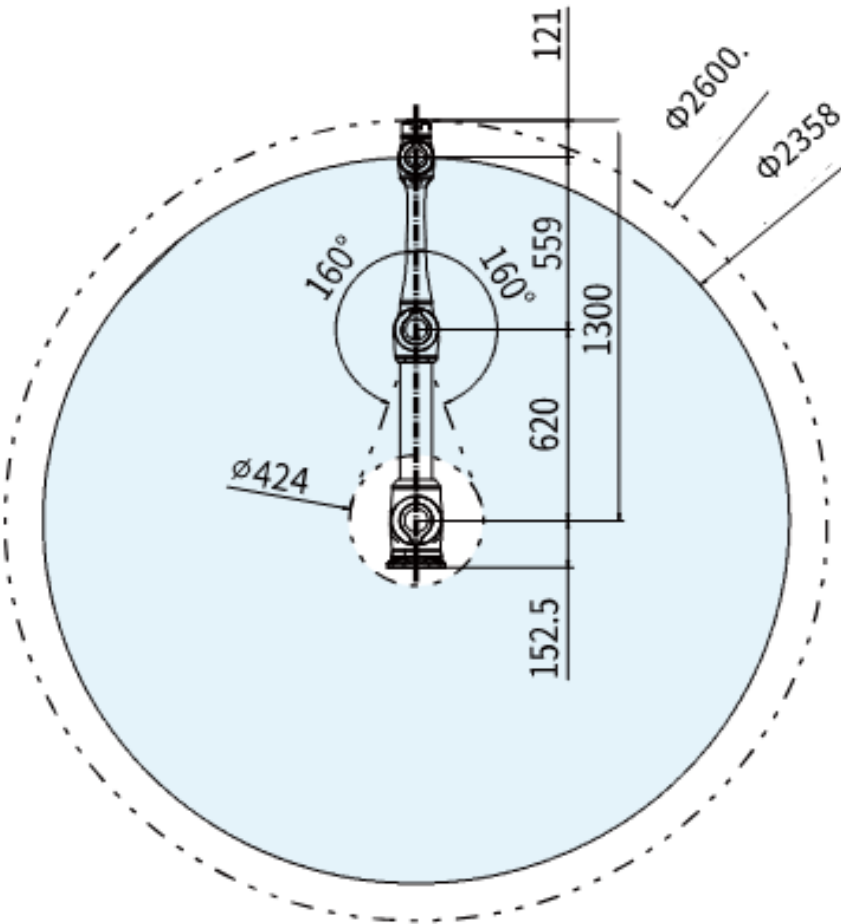

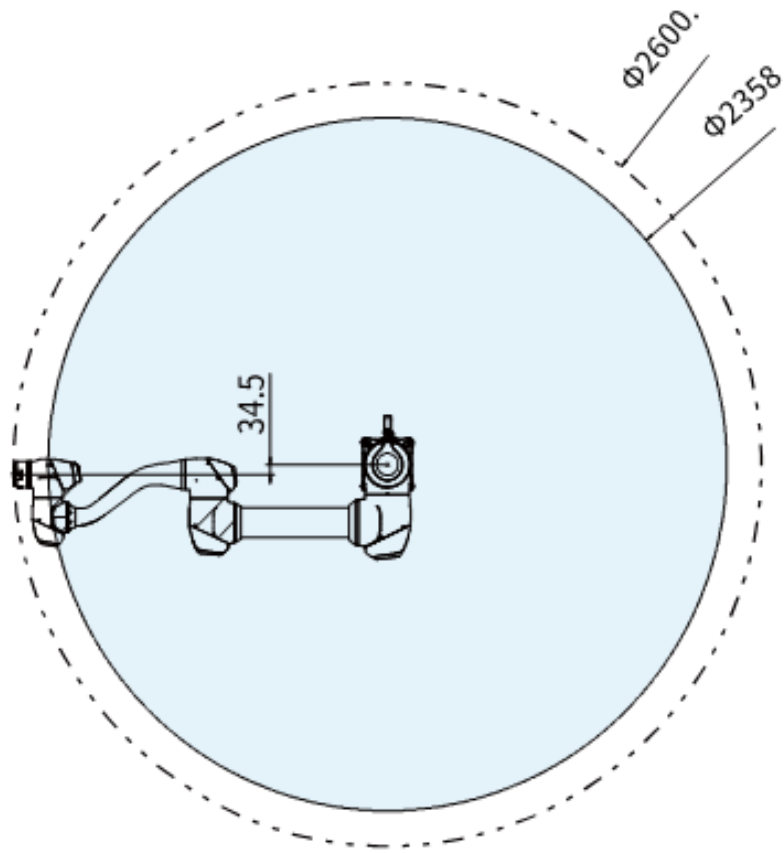

• M1509

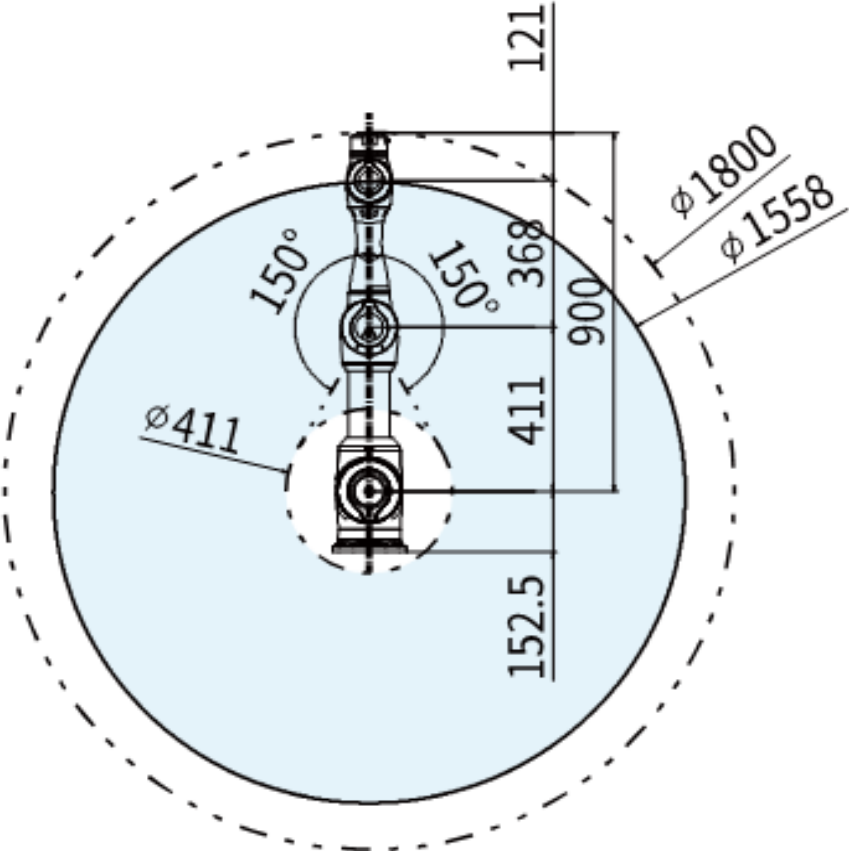

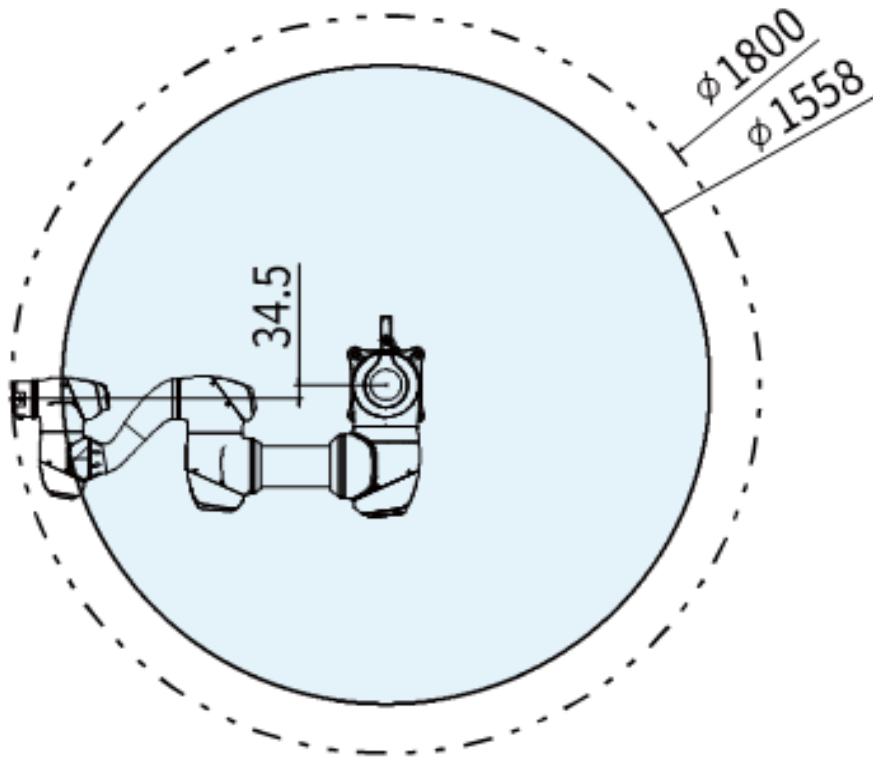

• H2017

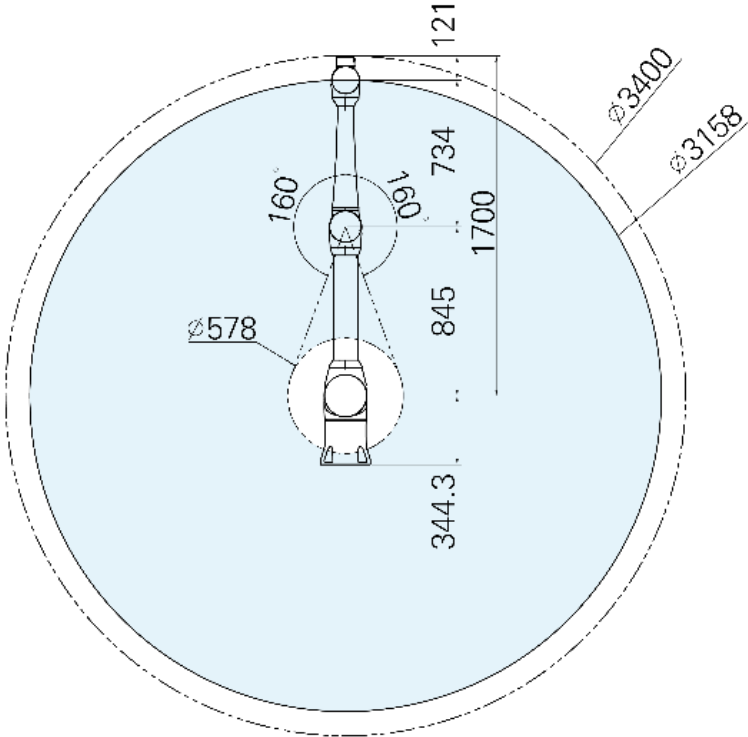

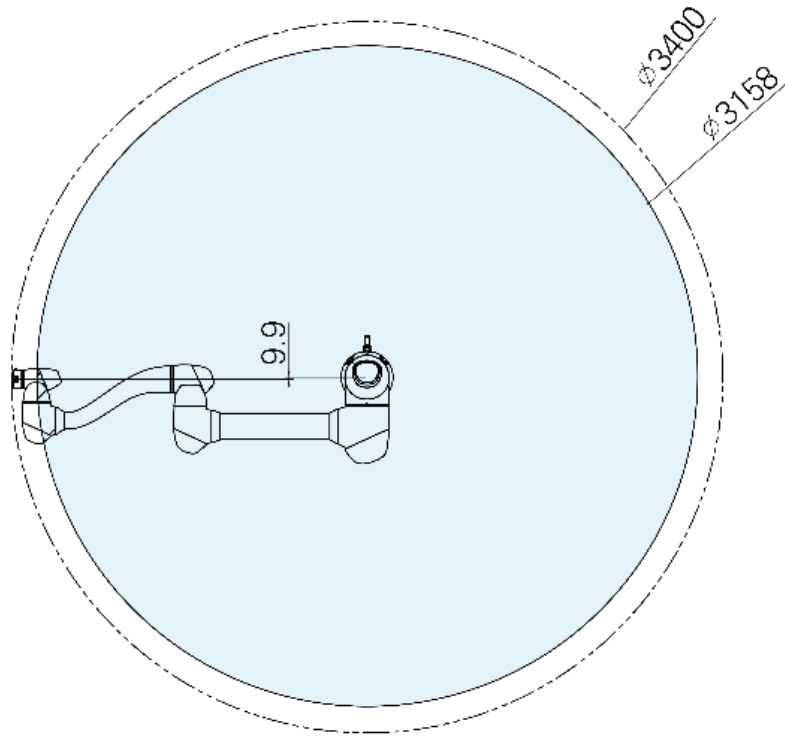

• H2515

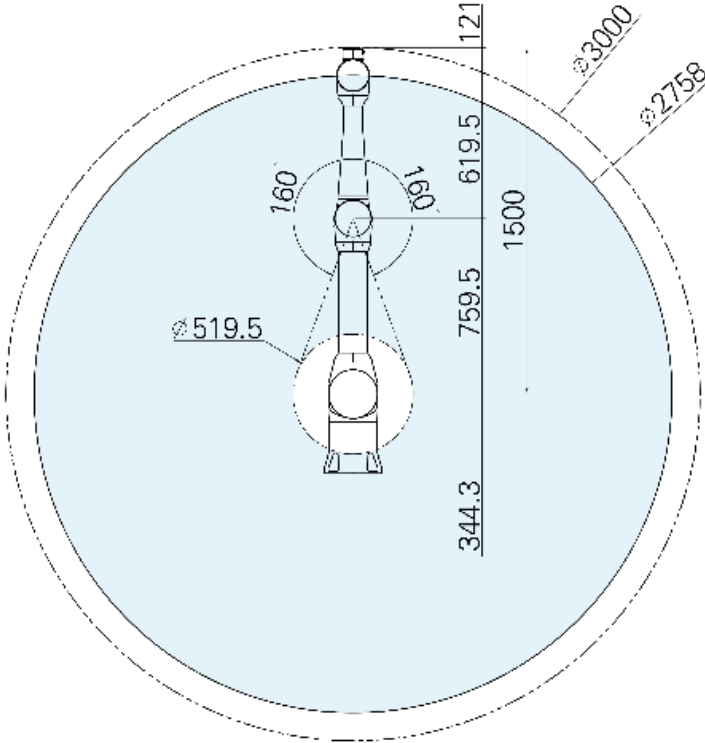

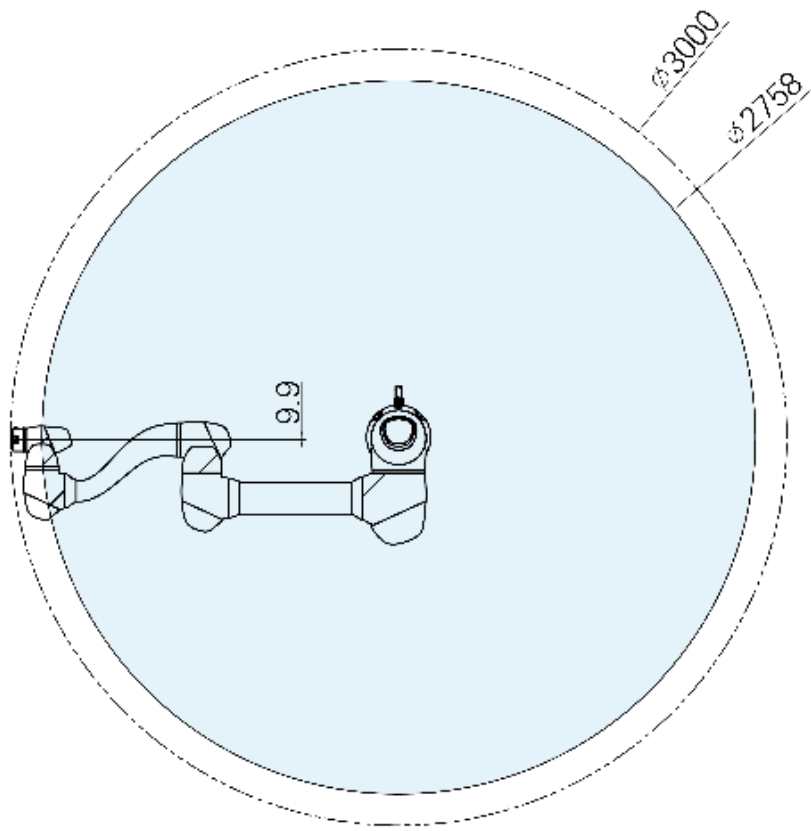

2.5.4 Max. Payload within operating space

The maximum payload of the robot within its operating space changes according to the distance from the center of gravity. Payload per distance is as follows:

- M0609

M0609_Payload Diagram @ Workspace

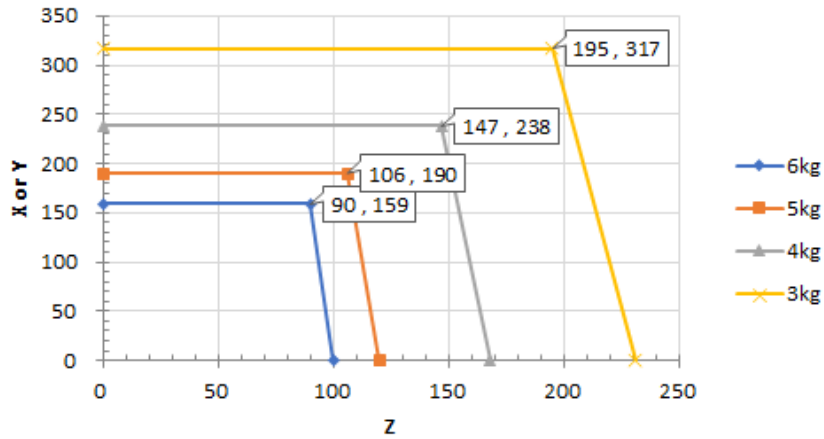

- M0617

M0617_Payload Diagram @ Workspace

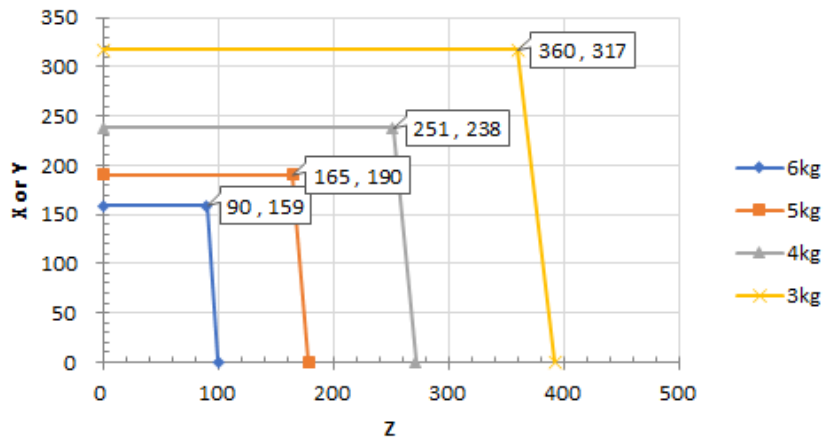

- M1013

M1013_Payload Diagram @ Workspace

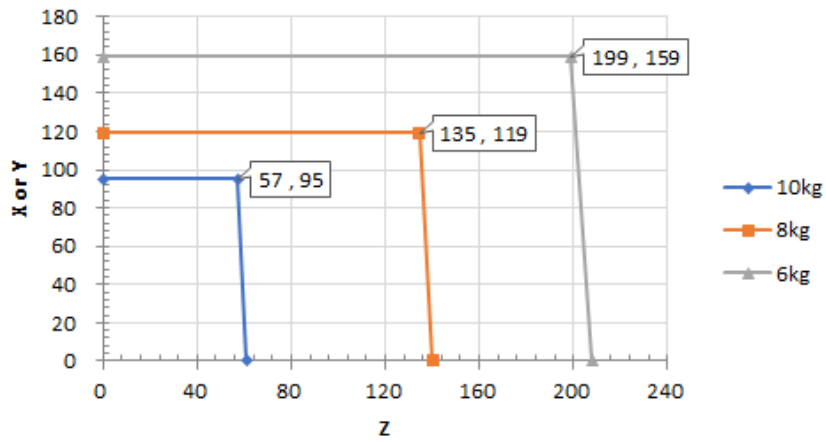

- M1509

M1509_Payload Diagram @ Workspace

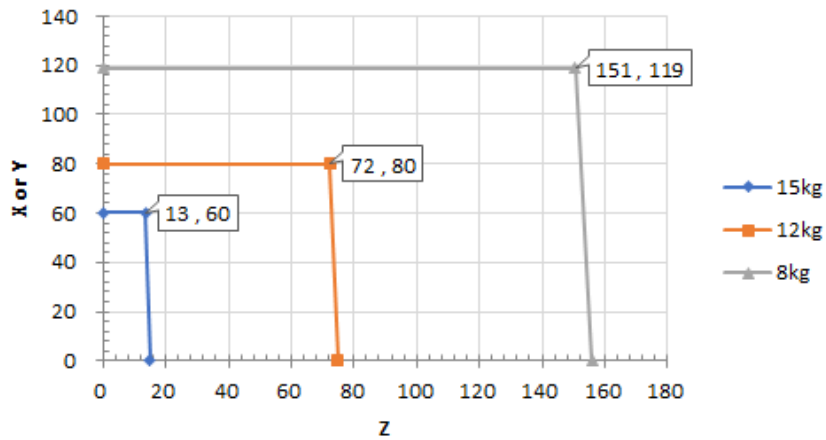

- H2017

H2017_Payload Diagram @ Workspace

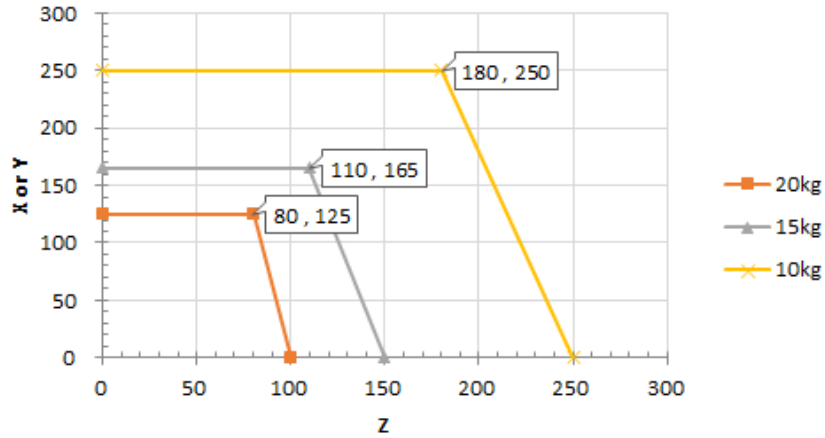

- H2515

H2515_Payload Diagram @ Work Space

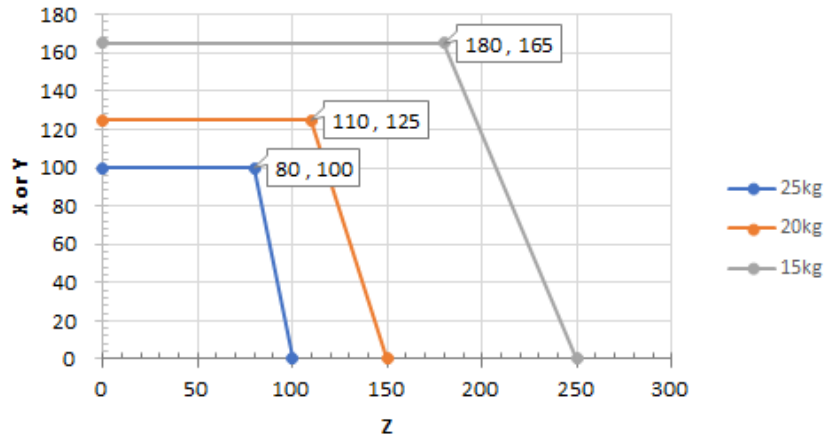

 **Note**

- This load diagram assumes a small tool load volume. Tools with a larger volume will have greater limitations in payload above the tool's center of gravity compared to a tool with an equal weight but smaller volume, and in such cases, vibration may occur.

2.5.5 Tool Center Point (TCP)

Refer to the figure below for TCP.

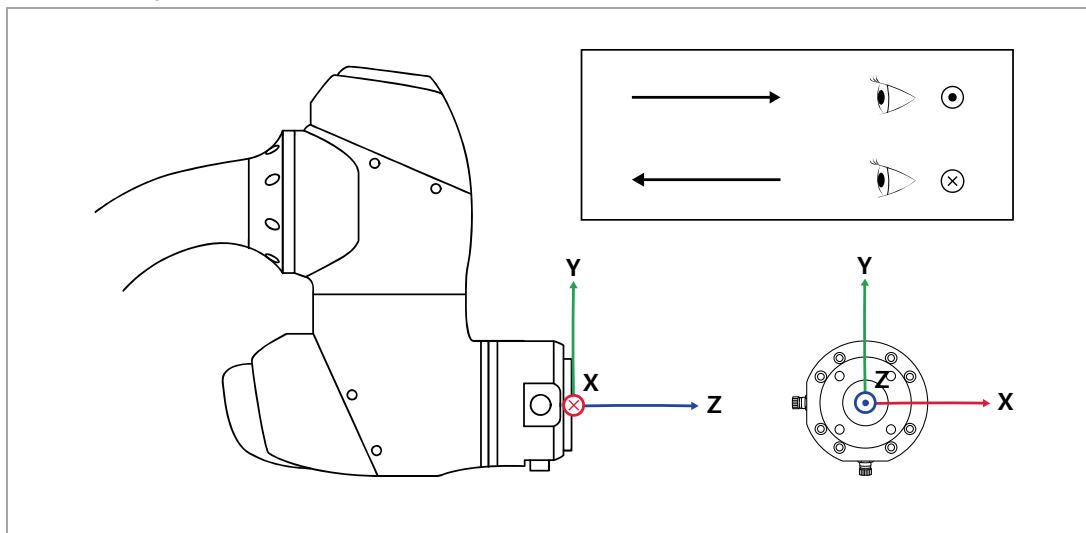

2.6 Nameplate and Label

Be careful not to remove or damage labels attached to the robot and controller.

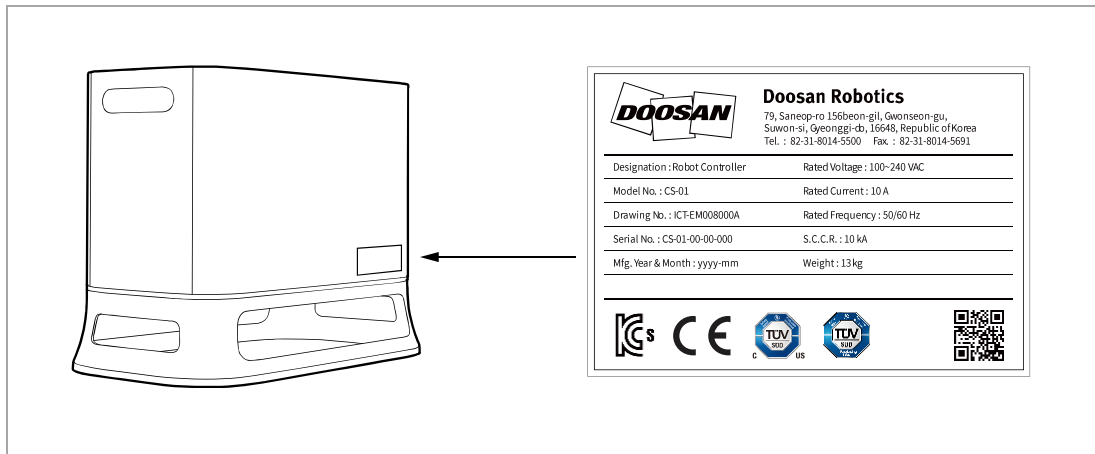
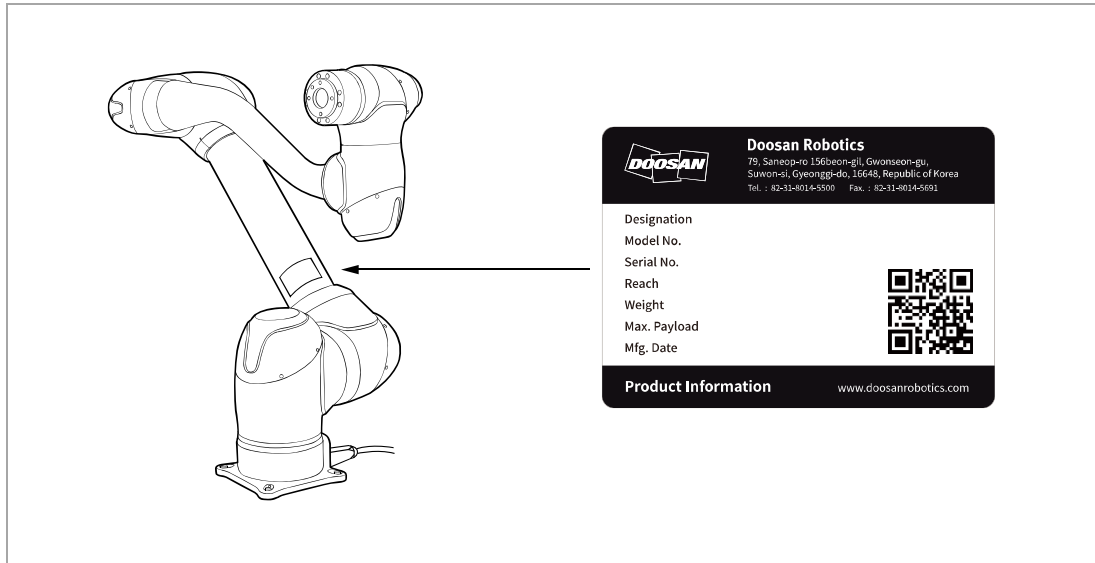

Note

- If you have selected an optional controller, please check the appendix as the label attachment location may vary.

3. Installation

3.1 Cautions during Installation

Warning

- Secure sufficient space for installation before installing the robot. If not enough space is secured, the robot may be damaged or the user may be injured.
- Safety devices to be connected to the controller must be connected to a safety contact input terminal or a configurable digital I/O set to Safety I/O using dual signals. If safety devices are connected a regular I/O or are connected using single signals, the devices cannot satisfy the required safety level.

Do not touch the power plug and power cable with wet hands when connect them to a power source. This can cause electrocution or injury. The maximum payload of the robot within its operating space changes according to the distance from the center of gravity. Refer to the tool center information provided in the manual.

Caution

- Ensure that the mounting bolts are completely tightened during installation. If the mounting bolts become loose, the base and robot may separate during operation, resulting in breakdowns.
- Make sure that safety measurements and robot safety setting parameters are correctly defined according to the risk assessment. If this is not established, the robot may be damaged or the user may be injured.
- Correctly set robot installation-related settings such as robot mounting angle, TCP weight, TCP offset and safety settings. If this is not established, the robot may be damaged or the user may be injured.
- For H-series, the robot can only be installed on the floor. To prevent safety accidents, consider the weight of the robot and refer to Handling Guide provided in this manual.

3.2 Installation Environment

Secure sufficient space to allow the robot to move freely. Check the operating space of the robot to ensure that the robot does not collide with external elements.

3.2.1 Installation Location Check

Before installing the robot, make sure you have enough space and consider the following.

- Install the robot on a firm, even surface.
- Install the robot in a location with no water leakage and constant temperature and humidity.
- Check whether there are flammable and explosive materials near the installation location.



- Installing the robot in locations other than the recommended locations may result in reduced robot performance and product life.

3.2.2 Robot Work Area Check

Secure installation space considering the operating space of the robot. The operating space varies according to the robot model.

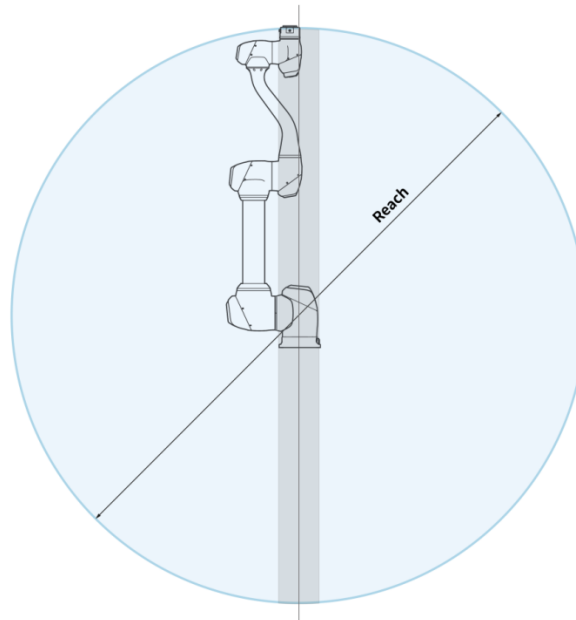

Note

- The grayed areas in the figure are areas where the robot has difficulty performing work. Within this area, the speed of tools is low but the speed of joints is high, so it becomes difficult to perform risk assessment in this area because the robot operates inefficiently. Therefore, it is not recommended to operate the tool passing through the cylindrical section on the top and bottom of the base.

3.3 Hardware Installation

Install the robot, controller and teach pendant, the key components of the system in the work area, and supply power to them before operating the robot. The installation of each component is as follows:

3.3.1 Securing the Robot

Use M8 bolts in the four 9.0 mm holes on the manipulator base to secure the robot.

- It is recommended to use tightening torque of 20 Nm to tighten the bolts.
And use a washer(plain or spring) to prevent loosening of the tension caused by vibration.
- Use a $\Phi 5$ place marker pin to accurately install the manipulator in a fixed location.

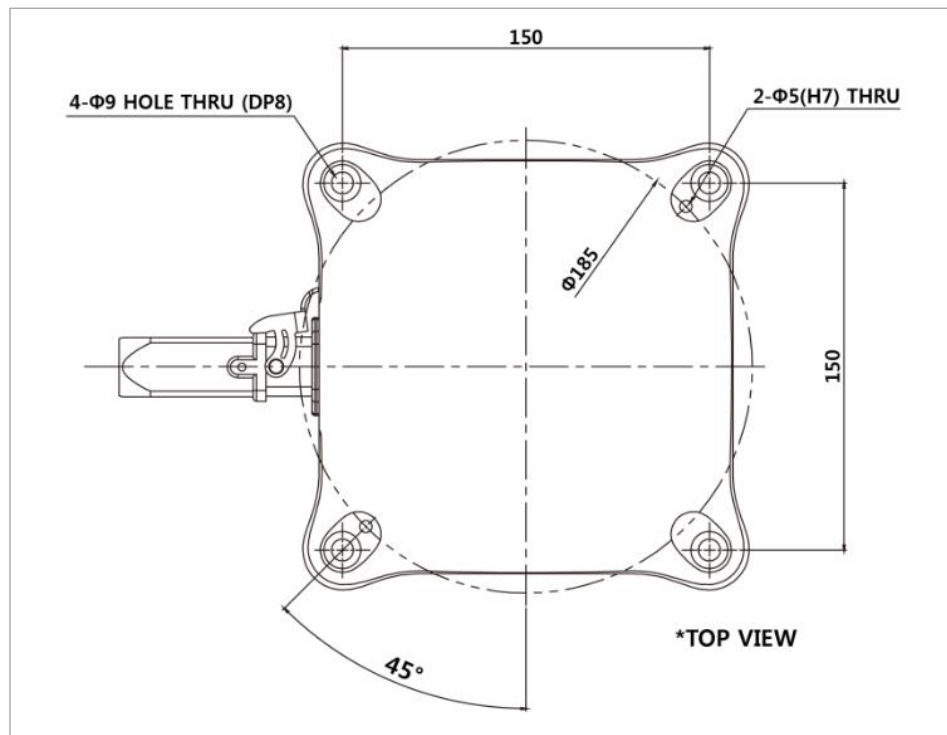

The manipulator base drawing and four M8 bolts are used (M series). Unit [mm]

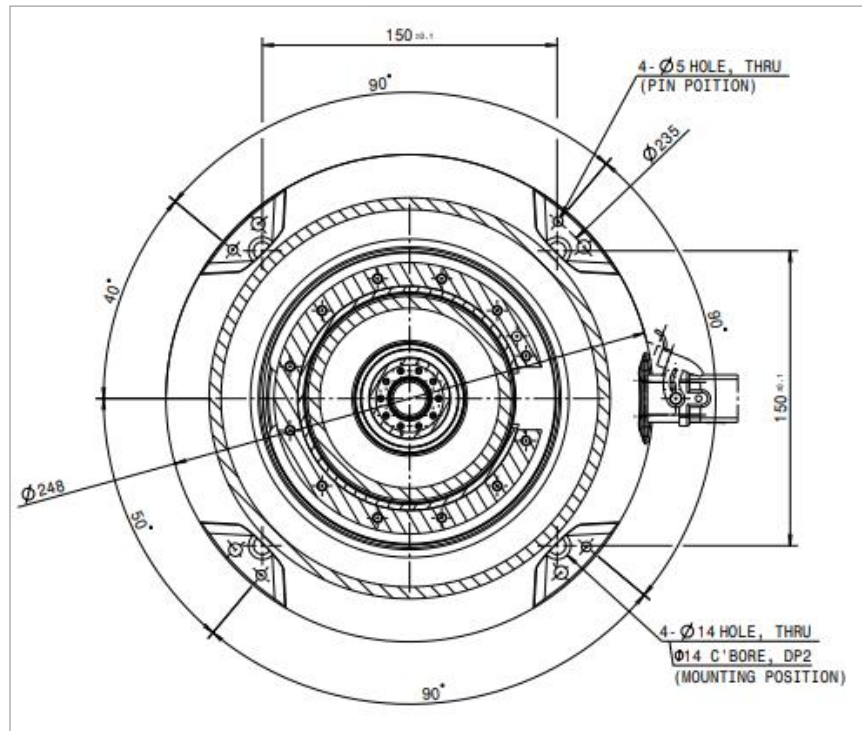

The manipulator base drawing and four M8 bolts are used (H series). Unit [mm]



Warning

- Tighten the bolts all the way to prevent loosening during manipulator operation.
- Install the manipulator base on a solid surface that can withstand the load generated during operation (10 times the maximum torque and five times the weight of the robot).
- The robot will interpret manipulator base vibration as a collision and engage the emergency stop. Therefore, for installation locations that automatically shift position, do not install the robot base in a location with high movement acceleration.
- Mount the manipulator arm in a specific location using appropriate methods. The mounting surface must be solid.
- The manipulator will be damaged if it comes in contact with water for an extended period of time. Do not operate the robot in conditions where it can get wet or under water.

3.3.2 Connecting the Robot and Tool

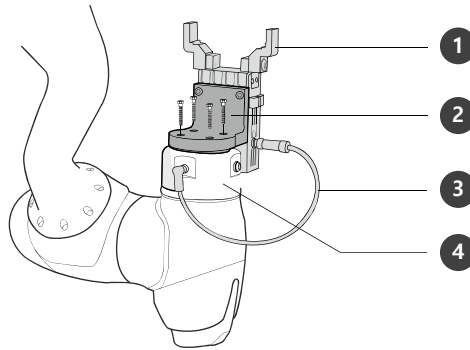

No.	Item
1	Tool
2	Bracket
3	Cable
4	Tool flange

- Use four M6 bolts to secure the tool on the tool flange.
 - It is recommended to use tightening torque of 9 Nm to tighten the bolts.
 - Use a $\Phi 6$ place marker pin to accurately install the robot in a fixed location.
- Connect the necessary cables to the flange I/O connectors after the tool is secured.

Note

- Methods of securing the tool may vary according to the tool. For more information about tool installation, refer to the manual provided by the tool manufacturer.

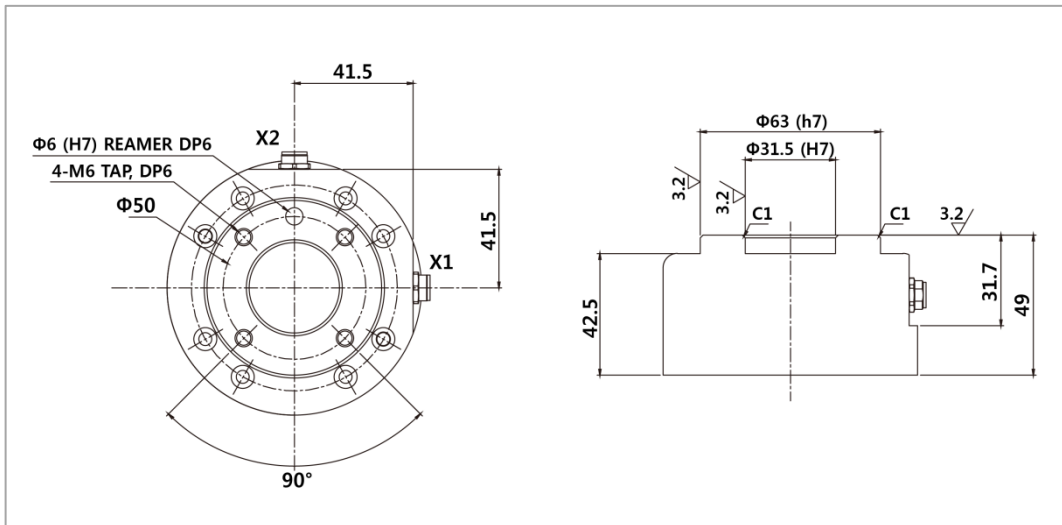

Tool output flange, ISO 9409-1-50-4-M6

3.3.3 Connecting the Manipulator and Controller

Connect the manipulator cable to the corresponding controller connector and place a securing ring on it to prevent the cable from becoming loose. Push the manipulator cable's opposite end into the corresponding controller connector until a click is heard to prevent the cable from becoming loose.

- 1 Connect the Manipulator cable to the controller, place a securing ring

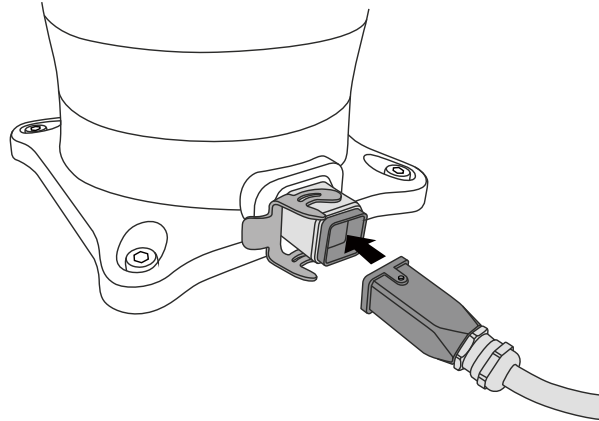

- 2 Connect the Manipulator cable's opposite end to the controller connector

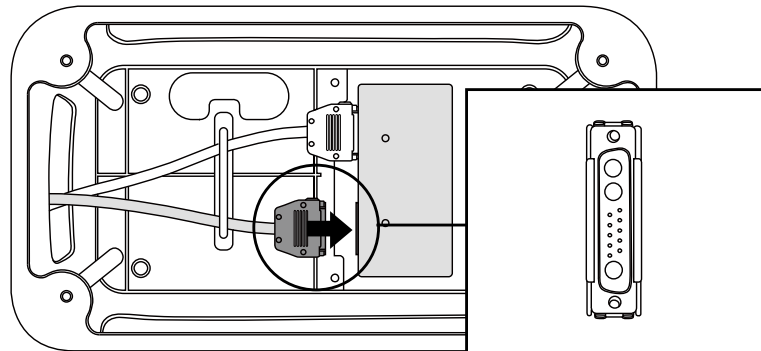

 **Caution**

- Do not disconnect the manipulator cable while the robot is turned on. This can cause damage to the robot.
- Do not modify or extend the manipulator cable.
- When installing the controller on the floor, secure at least 50 mm of space on each side of the controller to enable ventilation.
- Make sure that connectors are properly connected before turning on the controller.

 **Note**

- When configuring the system, it is recommended that a noise reducer be installed to prevent noise effects and malfunction of the system.
- If the controller is influenced by noise generated by electromagnetic waves, it is recommended to install a ferrite core on each side of manipulator cable to ensure normal operation. The installation location is as follows:

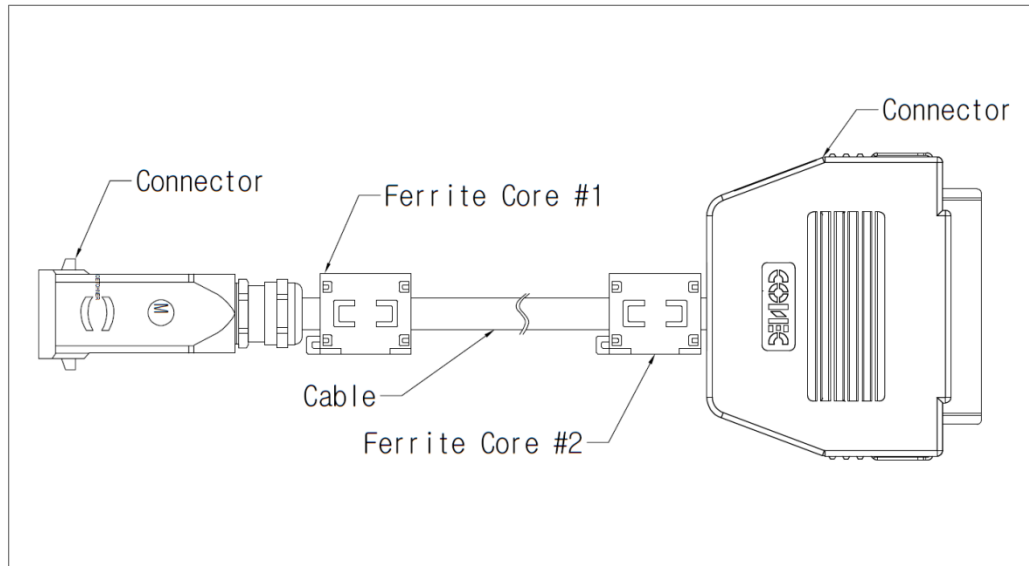

3.3.4 Connecting the Controller and Teach Pendant

Push the teach pendant cable into the corresponding controller connector until a click is heard to prevent the cable from becoming loose.

1 Connect the teach pendant cable to the controller connector

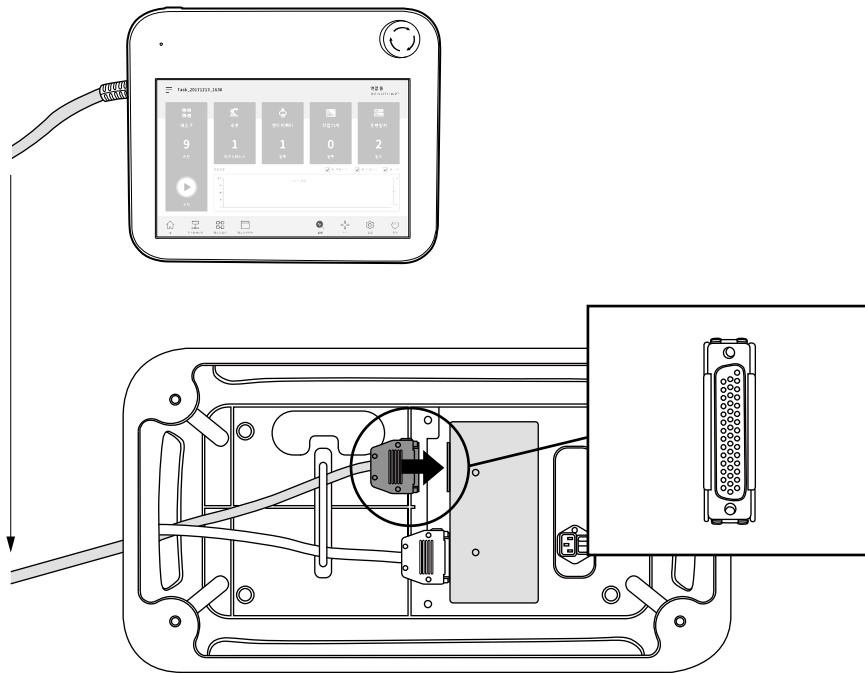

Caution

- Make sure that the pins of the cable end are not damaged or bent before connecting the cable.
- If the teach pendant is used by hanging on a wall or on the controller, be careful not to trip on the connecting cables.
- Be careful not to allow the controller, teach pendant and cable come in contact with water.
- Do not install the controller and teach pendant a in a dusty or wet environment.
- The controller and teach pendant must not be exposed to a dusty environment that exceeds IP20 ratings. Be especially careful in environments with conductive dust.

 **Note**

- When configuring the system, it is recommended that a noise reducer be installed to prevent noise effects and malfunction of the system.
- If the teach pendant is influenced by noise generated by electromagnetic waves, it is recommended to install a ferrite core on the Teach Pendant connection side to ensure normal operation. The installation location is as follows:

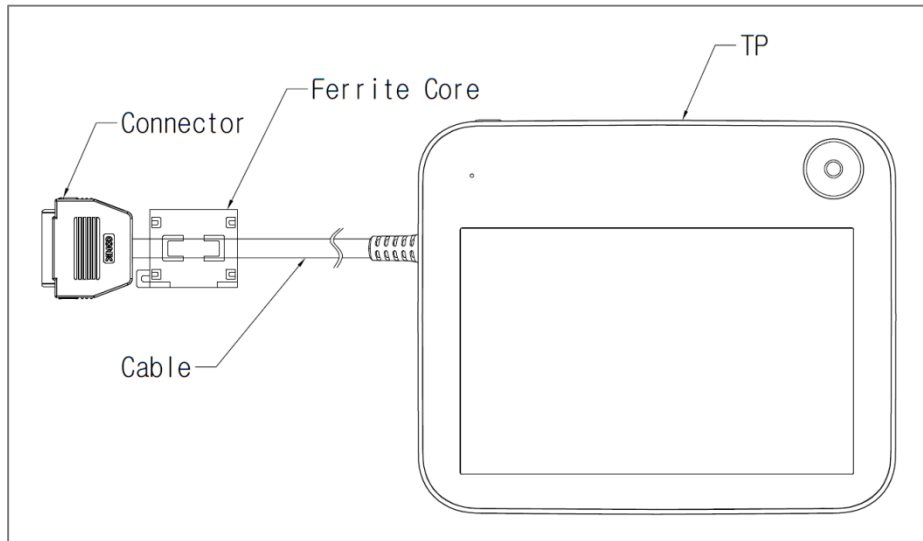

3.3.5 Routing of Manipulator Cable and Teach Pendant Cable

Ensure that the manipulator and teach pendant cable curvature radius is greater than the minimum curvature radius (120 mm) during routing.

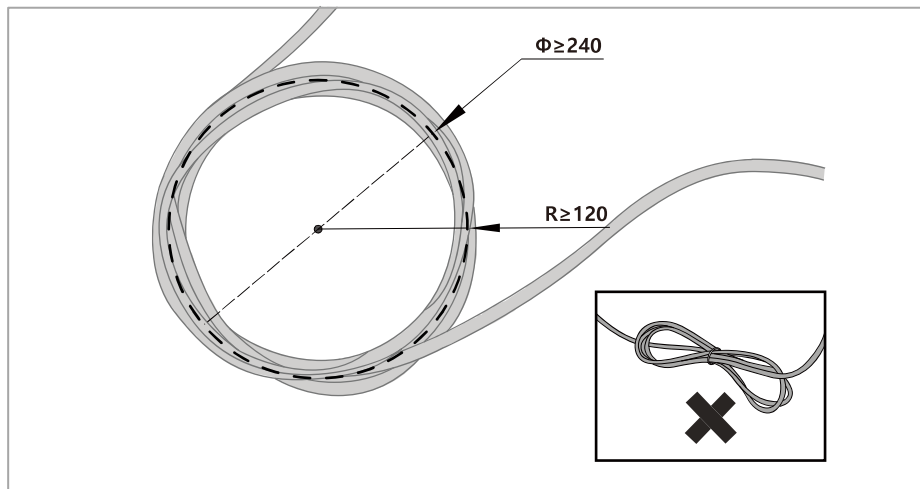

Caution

- Ensure that the curvature radius between the teach pendant cable and teach pendant connector is greater than the minimum curvature radius (120 mm).
- If the curvature radius is smaller than the minimum curvature radius (120 mm), cable disconnection or product damage may occur.
- In environments where electromagnetic noise can occur, proper cable installation must be taken to prevent malfunctions.

3.3.6 Supplying Power to the Controller

To supply power to the controller, connect the power cable of the controller to a standard IEC power outlet.

- Use a cable with a standard power plug that matches the outlet of the country of use.
- Push the plug completely into the corresponding controller connector to prevent the cable from becoming loose. Connect a standard IEC C14 plug and corresponding IEC C13 cord (refer to below) to the controller.

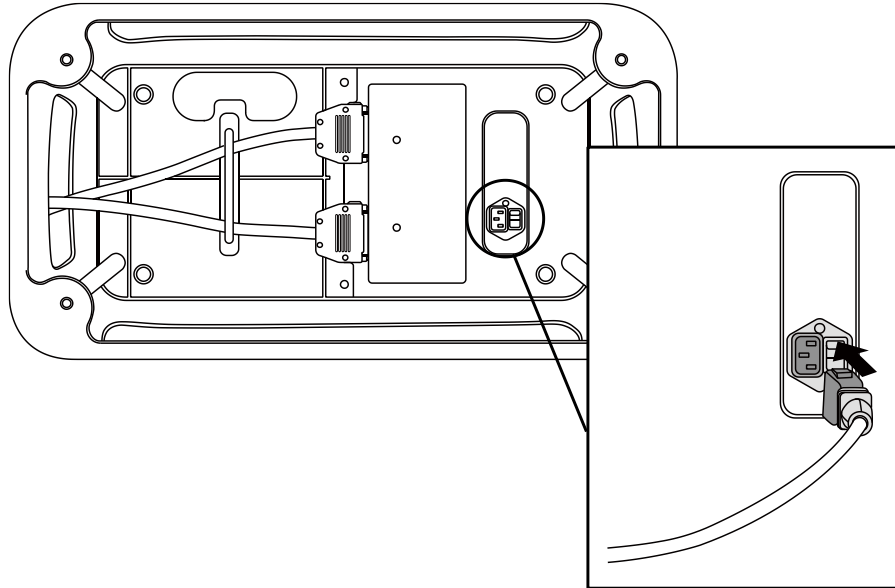

Warning

- After connecting the power cable, make sure that the robot has established a proper ground (electronic ground connection). Establish a common ground for all equipment in the system with an unused bolt related to the ground symbol inside the controller. The ground conductor must satisfy the maximum current rating of the system.
- Protect the input power of the controller using a circuit breaker.
- Do not modify or extend the power cable. It can cause fire or controller breakdown.
- Make sure that all cables are properly connected before supplying power to the controller. Always use the original cable included in the product package.

 **Note**

- When configuring the system, it is recommended to install a power switch that can turn off power to all devices in the system at once.
- If the input voltage is less than 195V, the robot's movement may be limited according to the load and motion.
- The power supply must satisfy minimum requirements such as ground and circuit breakers. The electrical specifications are as follows: (If you selected an optional controller, check the instructions in the appendix)

Parameter	Specification
Input Voltage	100 – 240 VAC
Input Power Fuse (@100-240V)	15 A
Input Frequency	47 – 63 Hz

4. Interface

4.1 Flange I/O

The end flange cover of the robot has two M8 spec 8-pin connectors, and refer to the figure below for the location and shape.

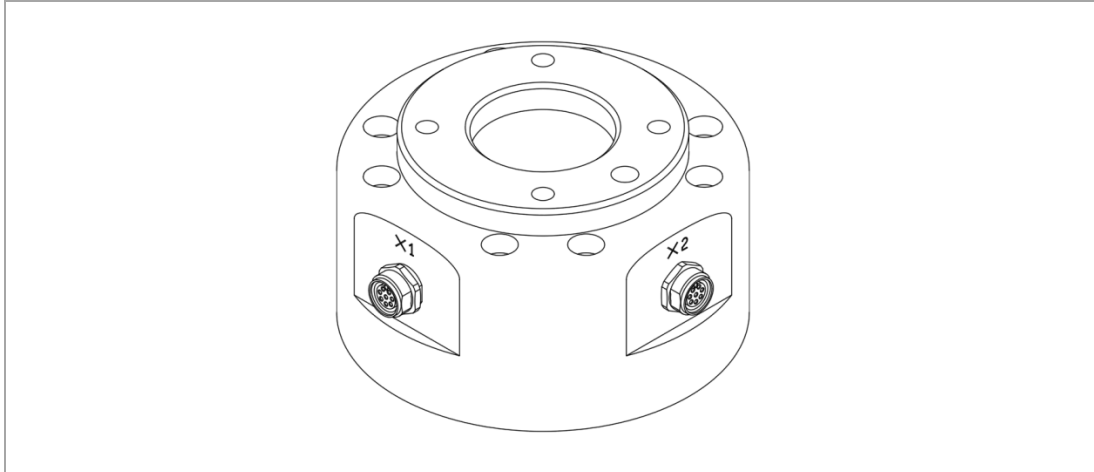

The two connectors supply power and control signals necessary to operate the gripper or sensors embedded within specific robot tools. The following are sample industrial cables (equivalent cables can be used):

- Phoenix contact 1404178, male (Straight)
- Phoenix contact 1404182, male (Right Angle)

The pin map of each connector is as follows:

• Schematic Diagram

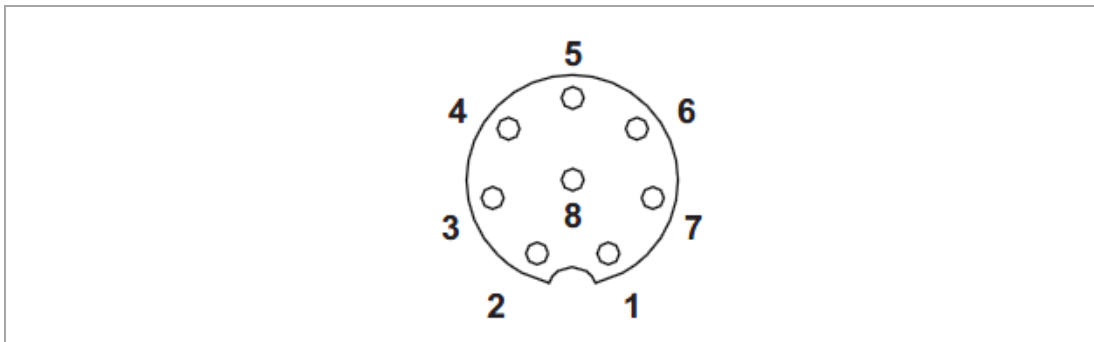

I/O functions provided through X1 and X2 connectors are different from each other, and refer to the table below for detailed I/O settings.

- X1 Setting (Digital I/O)

No	Signal
1	Digital Input 1
2	Digital Output 1
3	Digital Output 2
4	Digital Output 3
5	+24V
6	Digital Input 3
7	Digital Input 2
8	GND

- X2 Setting (Digital I/O)

No	Signal
1	Digital Input 4
2	Digital Output 4
3	Digital Output 5
4	Digital Output 6
5	+24V
6	Digital Input 6
7	Digital Input 5
8	GND

Internal power of flange I/O is set to 24V, and refer to the table below for detailed power specifications during I/O connection.

Parameter	Min	Typ	Max	Unit
Supply voltage	-	24	-	V
Supply current	-	-	3	A
Digital output	-	6	-	EA
Digital input	-	6	-	EA



Warning

- Set up the tool and gripper so that they do not cause any hazards when power is cut off. (e.g., workpiece falling from the tool)
- The No. 5 terminal of each connector outputs 24V at all times while power is supplied to the robot, so make sure to cut the power supply to the robot when setting up the tool and gripper.

4.1.1 Flange Digital Output Specifications

Flange digital output is a PNP specification, and photo coupler output is set up in the output.

The corresponding output channel becomes +24V when digital output is activated. The corresponding output channel becomes open (floating) when digital output is deactivated.

The electrical specifications of the digital output are as follows:

Parameter	Min	Typ	Max	Unit
Voltage when driving 10mA	23	-	-	V
Voltage when driving 50mA	22.8	-	23.7	V
Current when driving	0	-	50	mA



Caution

- Digital output is not subject to current limitation. Ignoring the specifications presented above during operation may cause permanent damage to the product.
- The figure below is an example of a digital output setup, so refer to it while connecting the tool and gripper. Make sure to disconnect the power from the robot when setting up the circuit.

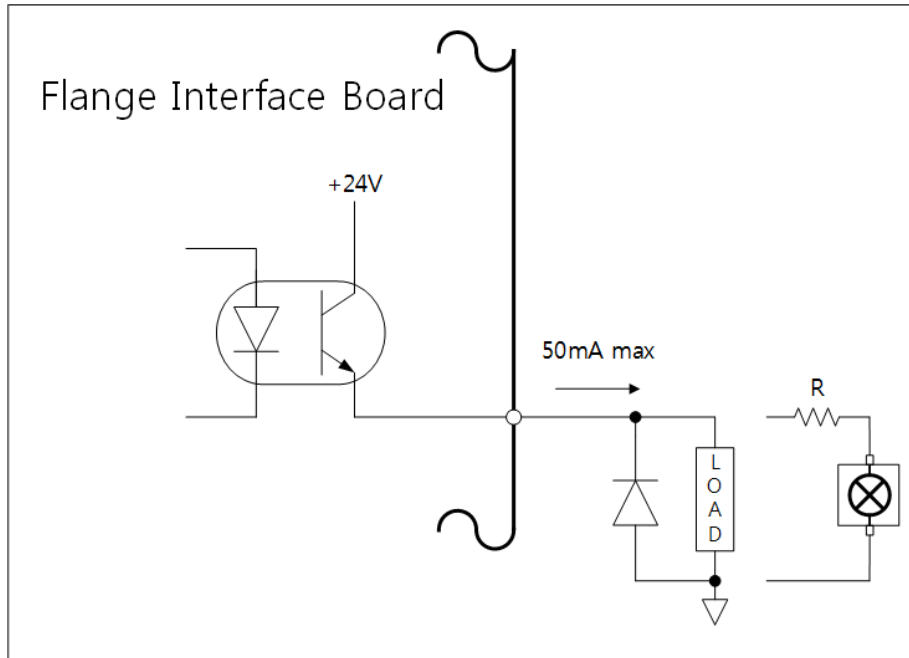

4.1.2 Flange Digital Input Specifications

Flange digital input features a photo coupler input.

The current based on 24V input is limited to 5mA by internal resistance.

The electrical specifications of the digital input are as follows:

Parameter	Min	Typ	Max	Unit
Input voltage	0	-	26	V
Logical high	4.4	-	-	V
Logical low	0	-	0.7	V
Input resistance	-	4.4k	-	Ω

The figure below is an example of a digital input setup, so refer to it while connecting an input device.

Make sure to disconnect the power from the robot when setting up the circuit.

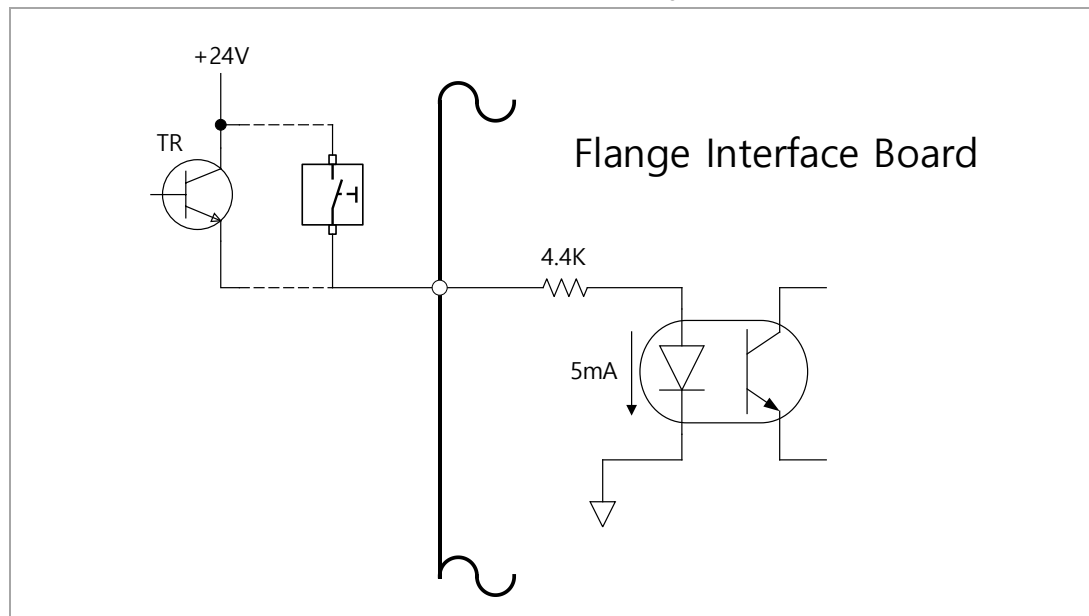

4.2 Connecting Controller I/O

In addition to the manipulator and teach pendant, various external equipment can be connected to the controller through the controller I/O terminal. Various peripherals such as safety devices, including emergency stop switch, light curtain and safety mats, and devices required during robot work cell setup including pneumatic solenoid valves, relays, PLCs and conveyor belt encoders can be connected. The controller I/O consists of the following six units:

- Terminal Block for Safety Contact Input (TBSFT): Used to connect devices required for emergency stopping and protective stopping
- Terminal Block for Safety Contact Output (TBSTO): Used to connect a power switch
- Terminal Block for Digital I/O Power (TBPWR):
- Configurable Digital IO Block (TBCI1- 4, TBCO1– 4): Used to connect peripherals required for robot operation
- Terminal Block for Analog I/O (TBAIO):
- Terminal Block for Encoder Input (TBEN1, TBEN2)

The figure below depicts the electric interface layout of the controller interior.

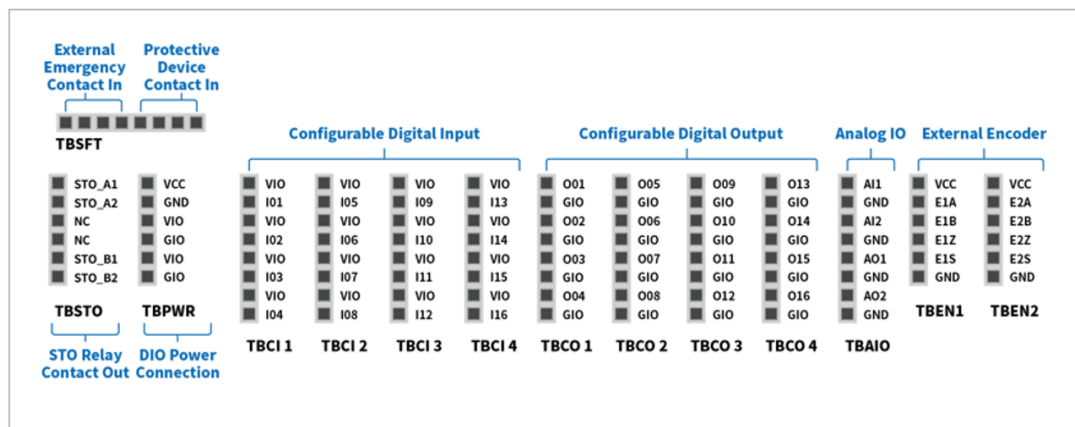

Caution

- Turn off the power when connecting terminals to the controller I/O to prevent product damage and breakdown.
- Doosan Robotics will not compensate any product damage caused by inappropriate terminal connection or user negligence.
- Make sure to turn off the external power source when turning off the controller power.

4.2.1 Setting the Terminal Block for Contact Input (TBSFT)

The safety I/O of the controller consists of dual contact input terminals for connecting safety devices. These terminals are categorized into two groups depending on their use.

- Two pairs of external emergency contact in on the left: Used to connect devices required for emergency stopping such as external emergency switch.
- Two pairs of protective device connect in on the right: Used to connect devices for protective stopping such as light curtain and safety mat.

If no external safety device is connected, connect each contact input as follows:

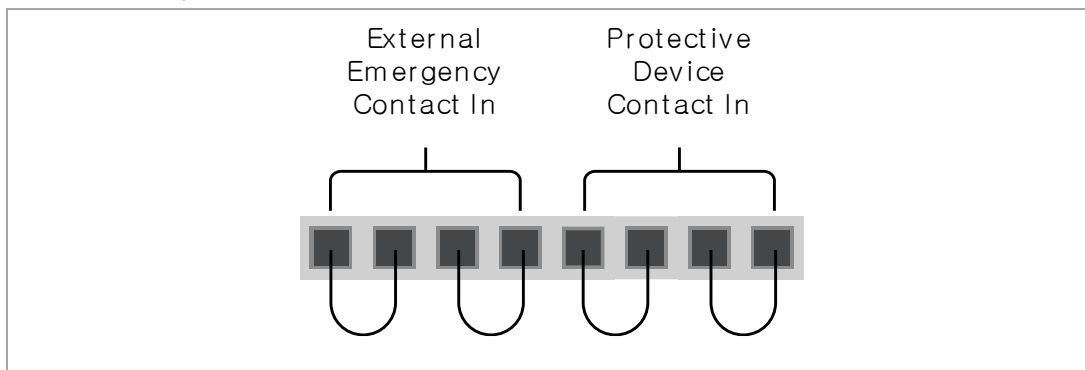

The external safety device signal recognized by the safety controller depending on the normally closed contact status, where all four contact inputs are normally closed, is as follows:

Contact Status	EM1 contact	EM2 contact	PR1 contact	PR2 contact
Close	Normal	Normal	Normal	Normal
Open	Emergency Stop	Emergency Stop	Protective Stop	Protective Stop



Warning

- Do not connect the safety signal to regular PLCs that are not safety PLCs. Failure to do this will result in inappropriate operation of the safety stop function, which can cause severe injury or death of the user.
- If any of the contacts are open, the robot will stop operation according to the safety stop mode setting, and the LED on the right side of the TBSFT lights up. EMGA (Red), EMGB (Red), PRDA (Yellow), PRDB (Yellow)



Caution

- To check for connection losses and connection shortages, this terminal must be connected to devices that output a safety signal as contacts. To connect peripherals that output safety signals as voltages to the safety controller, refer to the description for the Configurable Digital I/O Terminal Block.

4.2.2 Setting the Terminal Block for Safety Contact Output (TBSTO)

The safety controller supplies a dual relay contact output signal for safety purposes. If the robot is at power cut stop (STO: Safe Torque Off) status, each dual contact opens. If the robot is supplied with operating power (Ready, Run, Jog, etc.), each dual contact closes.

While the output value of the two contacts must be identical, different output values may be generated when open/close takes place. If the output values of the two contacts are longer than the times in the table below, assume connection shortage and hardware defect of the connected external device, and perform inspections. The rated voltage/current of the safety controller relay connected to the contact output terminal is 250VAC/6A.

	Open → Close	Close → Open
Contact output different Max. allowed time	Max. 1 sec.	Max. 0.1 sec.

4.2.3 Setting the Digital I/O Power Terminal (TBPWR)

VIO and GIO are power terminals used for the safety controller digital I/O located in the front of the controller, and they are separated from the VCC24V and GND, which supply SMPS inside the controller. If the user uses a current of 2A or less for the configurable digital I/O, and if there is no insulation for the connected I/O device and controller, the internal power supply of the controller can be used as the I/O power supply, as shown in the figure below. (factory default setting)

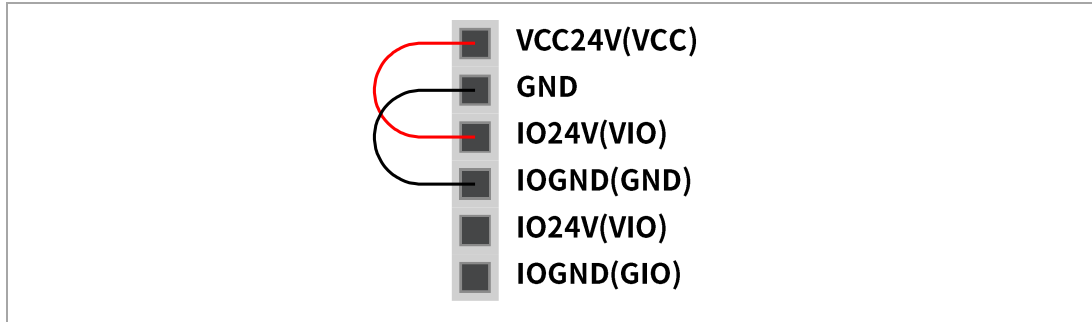

If a current greater than 2A is required, it is necessary to connect a separate external power source (24V) using VIO and GIO.

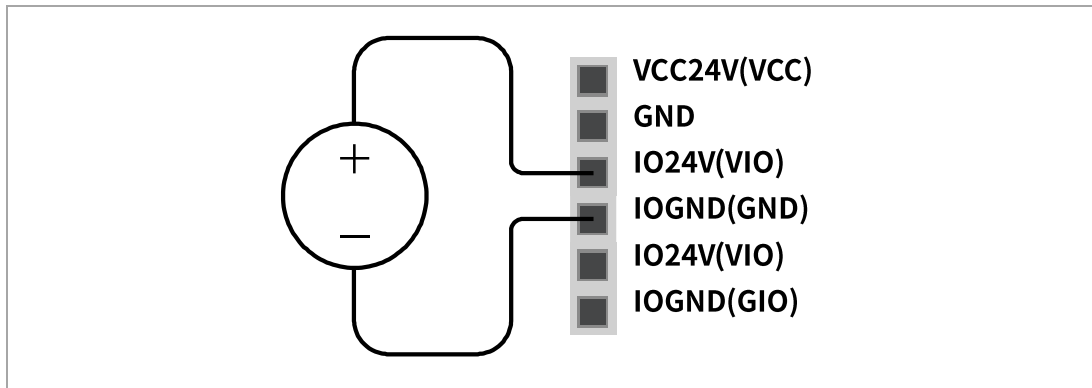

The IOPW (green) LED located on top of the TBPWR lights on if VIO power is supplied.



Caution

- Make sure to turn off the external power source (SMPS) when turning off the power for the controller.



Note

- If a current greater than 2A is used by the connected VCC and GND of TBPWR, the fuse in front of the terminal power output shorts to ensure the safety of the controller internal system connected to the same SMPS.
- If a current greater than 2A is required for the configurable digital I/O, make sure to connect an external power source (24V) to VIO and GIO.

4.2.4 Setting the Configurable Digital I/O (TBCI1 - 4, TBCO1 - 4)

The digital I/O of the controller consists of 16 inputs and 16 outputs. They are used to connect peripherals required for robot control or are set to dual safety I/O to be used for safety signal I/O purposes.

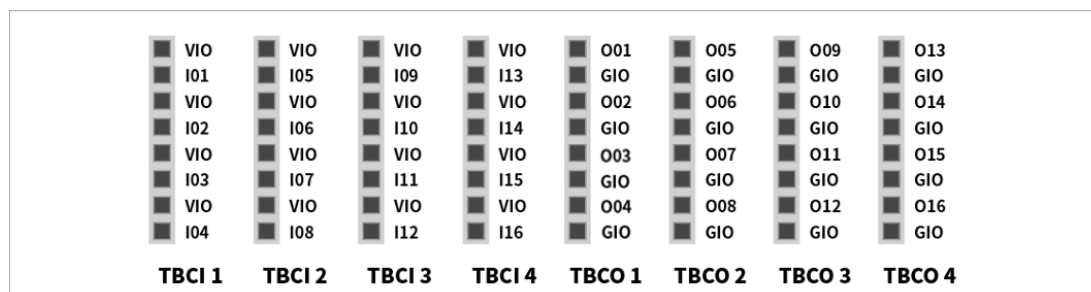

The electrical specifications of the configurable digital I/O are as follows:

	Terminal	Parameter	Specification
Digital Output	[Oxx]	Voltage	0 - 24 V
	[Oxx]	Current	0 - 1 A
	[Oxx]	Voltage Drop	0 - 1 V
	[Oxx]	Leakage Current	0 - 0.1 mA
Digital Input	[lxx]	Voltage	0 - 30 V
	[lxx]	OFF Range	0 - 5 V
	[lxx]	ON Range	11 - 30 V
	[lxx]	Current	2 - 15 mA



Caution

- The VIO (IO 24V) and GIO (IO GND) terminals that can be used as power supplies for digital I/O are separated from the VCC (24V) and GND of other power supplies on the safety I/O circuit. Take caution as the diagnostic functions of the robot will detect errors if the internal power supply is connected as a digital I/O power supply through the Terminal Block for Digital I/O Power (TBPWR), or if 24V power is not supplied to the VIO and GIO terminals through an external power supply, the configurable digital I/O does not work, and shuts off operating power to the robot.

If the configurable digital I/O is used as a general digital I/O, various low current operations such as solenoid valves for voltage and signal exchanges with PLC systems or peripherals can be performed. The following explains how to use the configurable digital I/O:

- If dry contact input is received

This is a method of connecting a switch or contact between the VIO terminal of terminal blocks TBCI1-TBCI4 and Ixx terminals. The output of the external device only acts on the open/close of the contact through the relay, so it is electrically insulated from external devices.

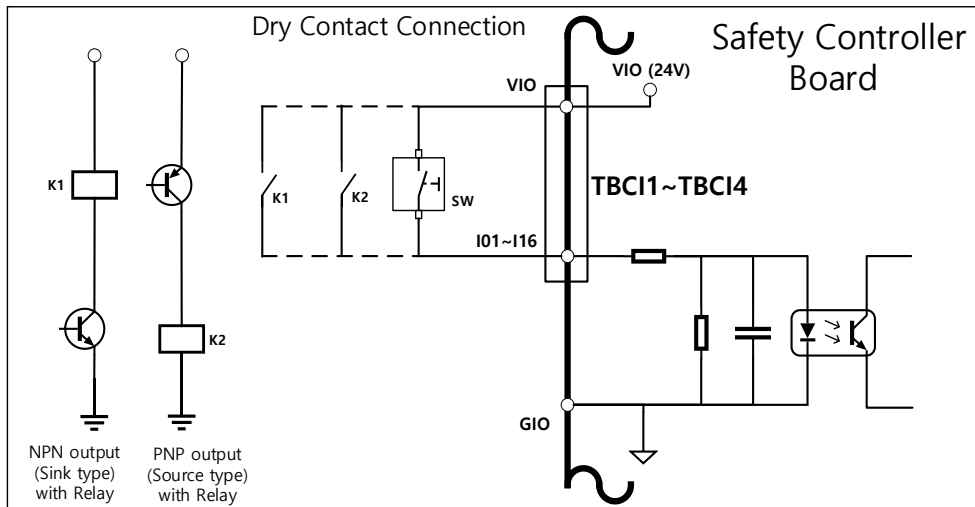

- If wet contact input is received

It receives voltage type signals from external devices. If the output of the target device is a source type, it receives a voltage of 24V/0V as input. If the output of the target device is a sink type, a relay can be added to receive voltage 24V/0V as input. Since voltage input requires a reference, the external devices and the external power supply must be connected to a common ground.

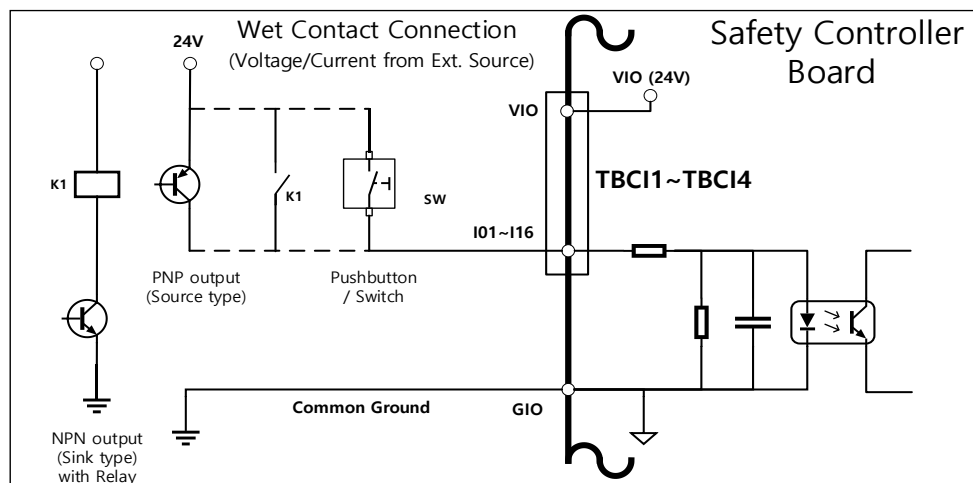

- If a simple load is operated

It is a method of connecting loads between the Oxx terminals of TBCO1-TBCO4 terminal blocks and the GIO terminal.

Each terminal is capable of outputting a maximum of 1A, but the overall current may be limited according to the calorific value and load.

If digital I/O power (VIO/GIO) is supplied through the internal power supply as in the factory default setting, up to 2A of VIO current can be used. If a total current greater than 2A is required, remove the connection between the digital I/O power supply (VIO/GIO) of the Terminal Block for Digital I/O Power (TBPWR) and the internal power supply (VCC/GND), and an external power supply must be connected.

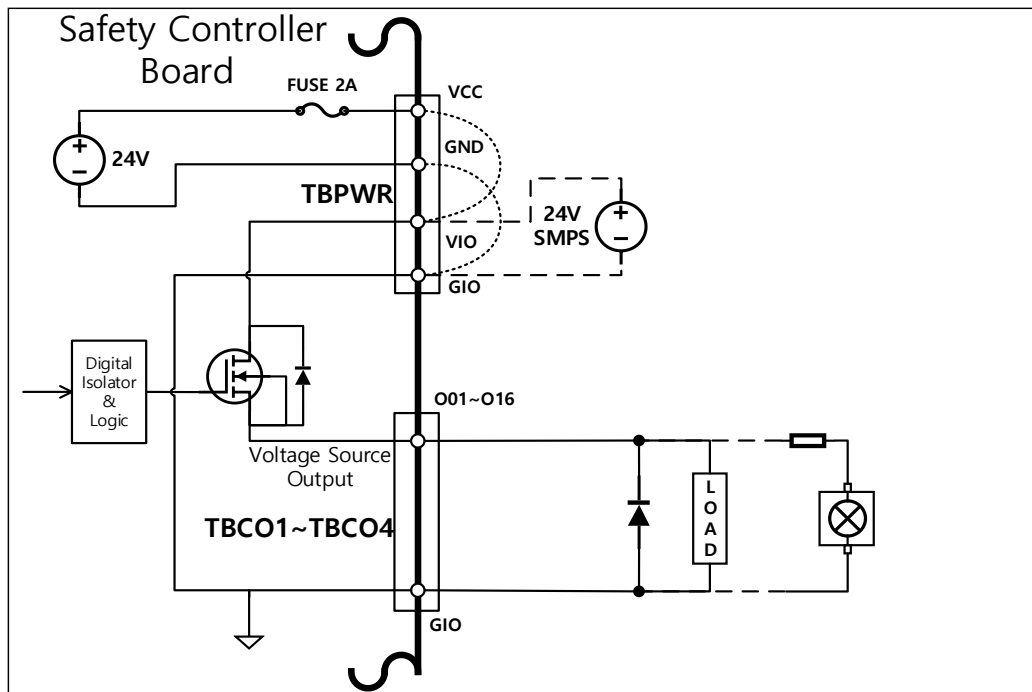

- If a negative common & sink type input device is connected

If digital I/O output is connected to a sink type input device, connect the Oxx terminals of the TBCO1-TBCO4 terminal blocks to the input terminal of the external device, and connect the GIO to the negative common of the external device to establish a common ground.

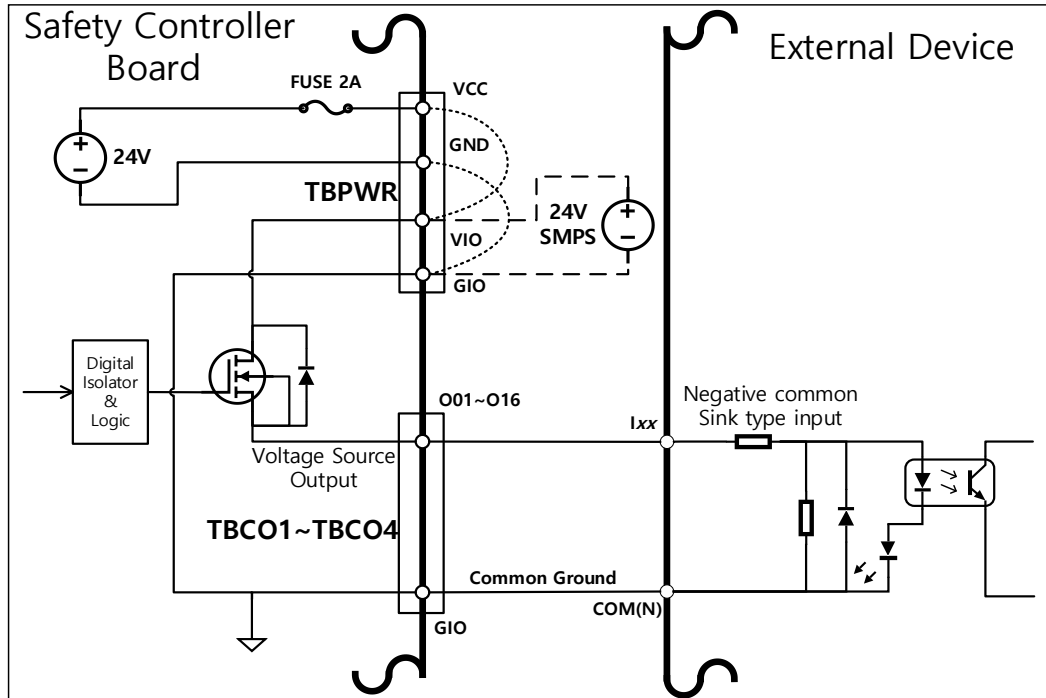

- If a positive common & source type input device is connected

Connect a relay between the Oxx terminal of the TBCO1-TBCO4 terminal blocks and GIO terminal to supply input signals as contacts to the external device. If necessary, an external power supply can be connected to the external device.

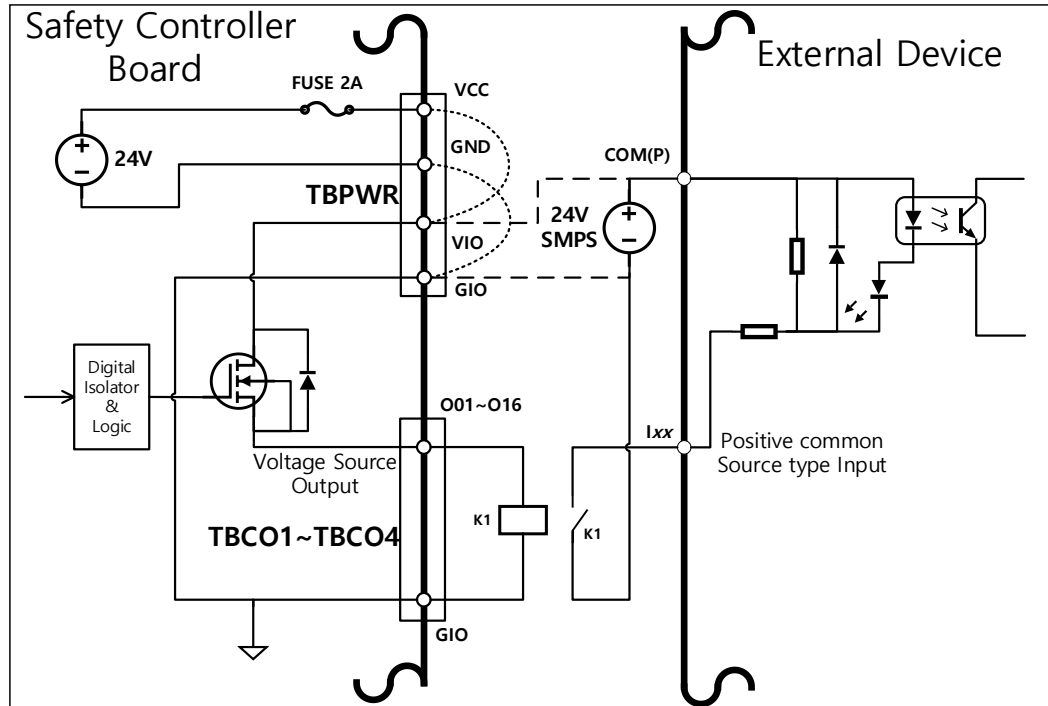

Caution

- General digital I/O devices can stop at any time due to controller power shortage, self-diagnosis error detection and work program setting. Therefore, perform risk assessment before setting up a robot workcell, and if additional risks such as workpiece falling, ignoring digital input or synchronization error due to incorrect recognition, make sure to implement additional safety measures.
- The general digital I/O is a single connection type I/O and any short circuits or breakdown can result in the loss of safety functions, so it cannot be used for safety purposes. If connection of safety devices or safety related I/O is required, make sure to set the corresponding terminal to dual safety I/O on the teach pendant.

If the configurable digital I/O is used as a safety I/O, two neighboring I/O terminals, such as O01 & O02, ... , O15 & O16, I01 & I02, ... I15 & I16, can use identical safety signals to form a dual safety I/O.

While the Safety Contact Output Terminal (TBSFT) can only be connected with contact type (Dry Contact) signals, input set as safety I/O can connect with both contact type (Dry Contact) and voltage type (Wet Contact) signals. Output set as safety I/O outputs voltage signals, but it can also output contact type signals by adding an external relay.

The following is an example of connecting a safety device for operation.

- Connect a contact type (Dry Contact) signal emergency switch as a safety input terminal

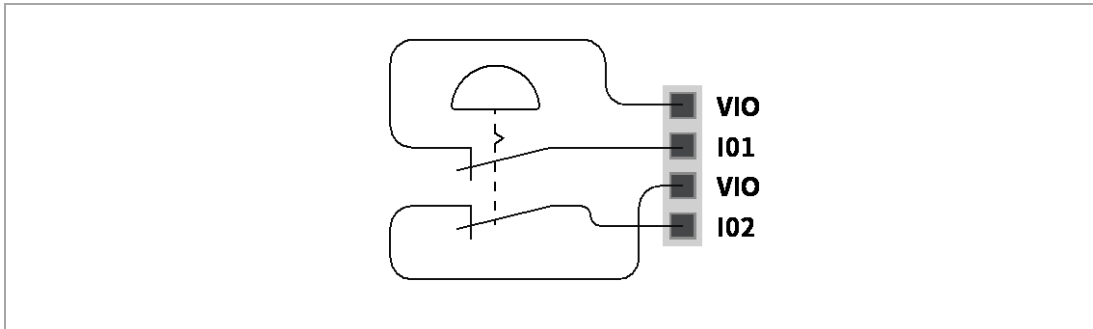

- Connect a voltage type (Wet Contact) signal light curtain as a safety input terminal (common ground)

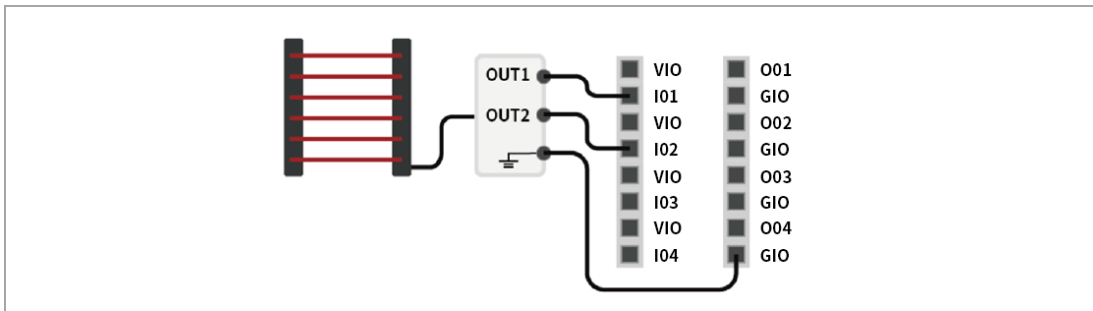

4.2.5 Setting Analog I/O Terminal (TBAIO)

The controller has two analog I/O terminals that can be set to voltage mode or current mode. It can output voltage/current through an external device operated using analog I/O or receive signals from sensors outputting analog voltage/current.

To ensure maximum input accuracy, observe the following:

- Use shielded or twisted pair cables.
- Connect the cable shield to the ground terminal inside the controller.
- Current signals are relatively less sensitive to interference, so use devices operating in current mode for analog I/O terminals. Current/voltage input modes can be set with the software.

The electrical specifications of the analog I/O terminal are as follows:

	Terminal	Parameter	Specification
Current mode analog input	[AIx-GND]	Voltage	-
	[AIx-GND]	Current	4 - 20 mA
	[AIx-GND]	Resistance	300 ohm
	[AIx-GND]	Resolution	12 bit
Voltage mode analog input	[AIx-GND]	Voltage	0 - 10 V
	[AIx-GND]	Current	-
	[AIx-GND]	Resistance	1M ohm
	[AIx-GND]	Resolution	12 bit
Current mode analog output	[AOx-GND]	Voltage	-
	[AOx-GND]	Current	4 - 20 mA
	[AOx-GND]	Resistance	50M ohm
	[AOx-GND]	Resolution	16 bit
Voltage mode analog output	[AOx-GND]	Voltage	0 - 10 V
	[AOx-GND]	Current	-
	[AOx-GND]	Resistance	1 ohm
	[AOx-GND]	Resolution	16 bit

- Voltage/current input

It receives voltage or current signals from an external device between the AIx terminal of the TBAIO terminal block and the GND terminal. If the output of the device is a voltage signal, it receives a signal of 0-10Vdc. If the output of the device is a current signal, it receives a signal of 4-20mA.

※ Depending on the output signal (voltage/current) of the device, it is necessary to set the controller analog input as “Voltage” or “Current” on the teach pendant.

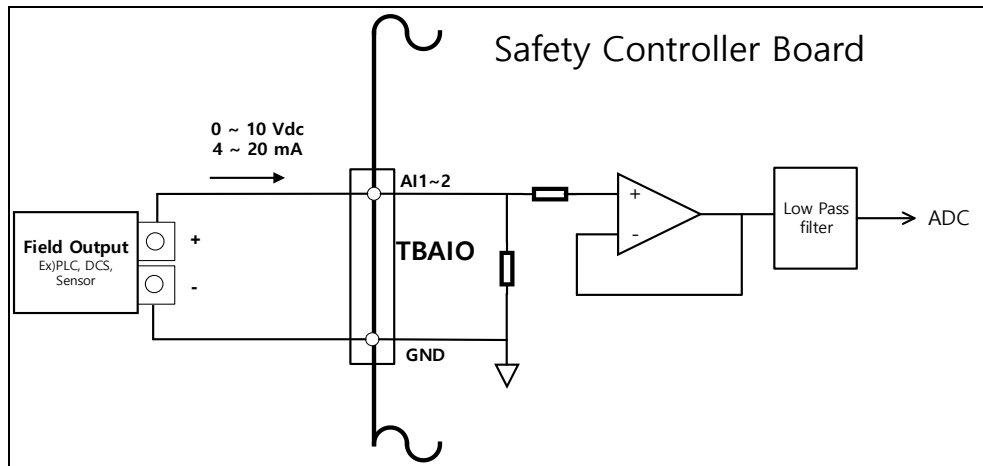

- Voltage/current output

It supplies voltage or current signals to an external device between the AOx terminal of TBAIO terminal block and GND terminal. If the input of the device is voltage signal, it supplies a signal of 0-10Vdc. If the input of the device is current signal, it supplies a signal of 4-20mA.

※ Depending on the input signal (voltage/current) of the device, it is necessary to set the controller analog output as “Voltage” or “Current” on the teach pendant.

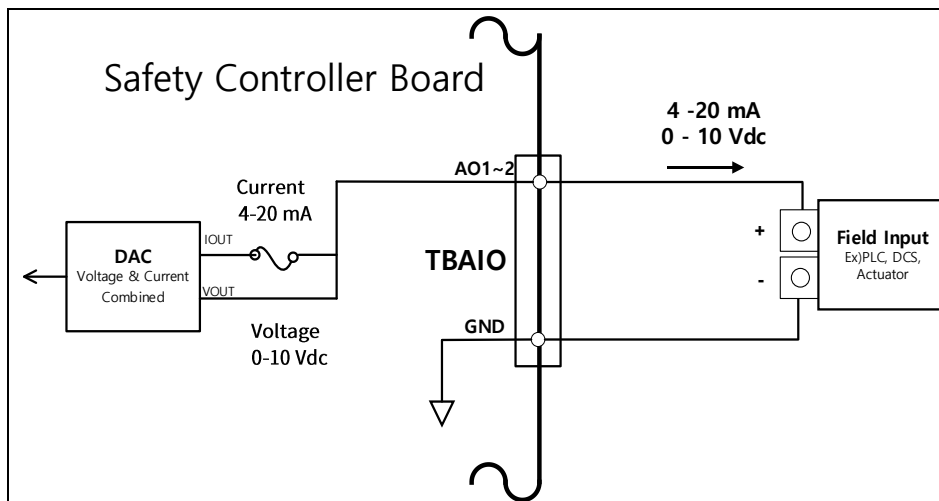

4.2.6 Setting Encoder Input Terminal (TBEN1, TBEN2)

The controller provides two TBEN terminals that allow the input of external encoders.

They support A, B and Z phases as inputs, and perform counts based on 12Vdc.

In addition, S phase can be used as the conveyor's Start sensor.

The figure below shows a sample encoder and sensor configuration, so refer to it while establishing connections.

- To ensure maximum input accuracy, observe the following: Use shielded, twisted pair cables to reduce noise.
- Connect the cable shield to the ground terminal inside the controller.
- Connecting Incremental Encoder A, B, Z phase

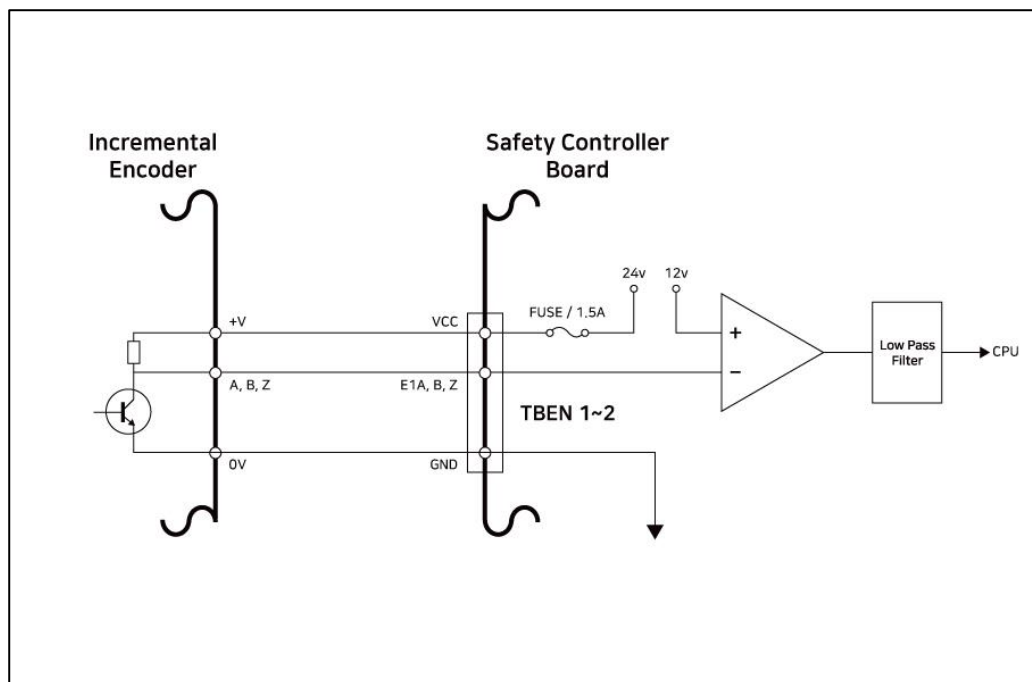

- In the case of S phase inputs, connect a pull-up or pull-down resistance according to the sensor type(NPN/PNP) to prevent floating.

- Connecting NPN Sensor

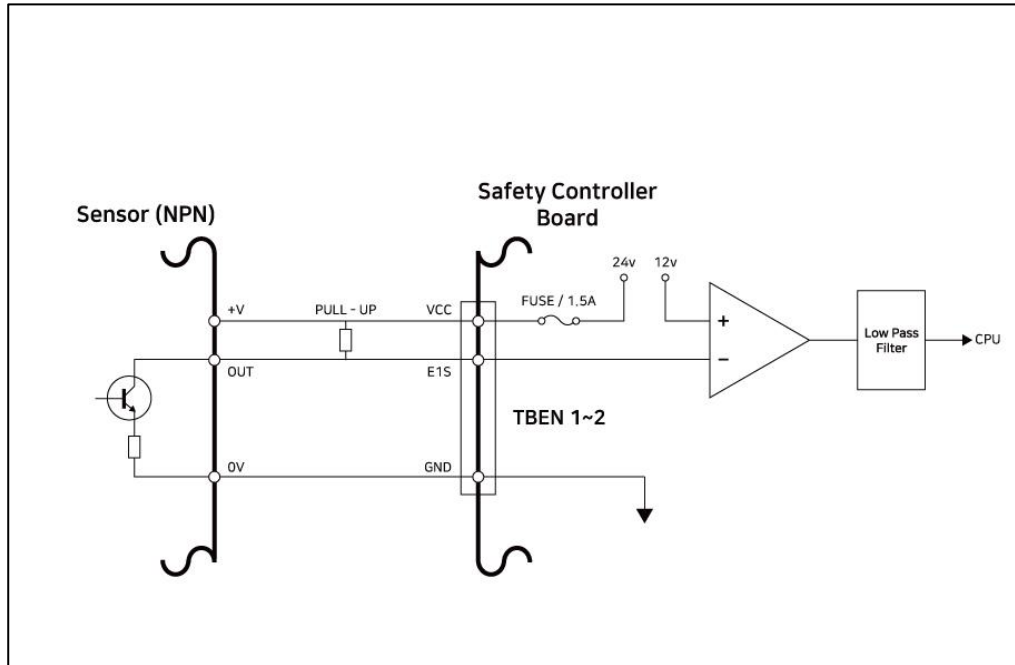

- Connecting PNP Sensor

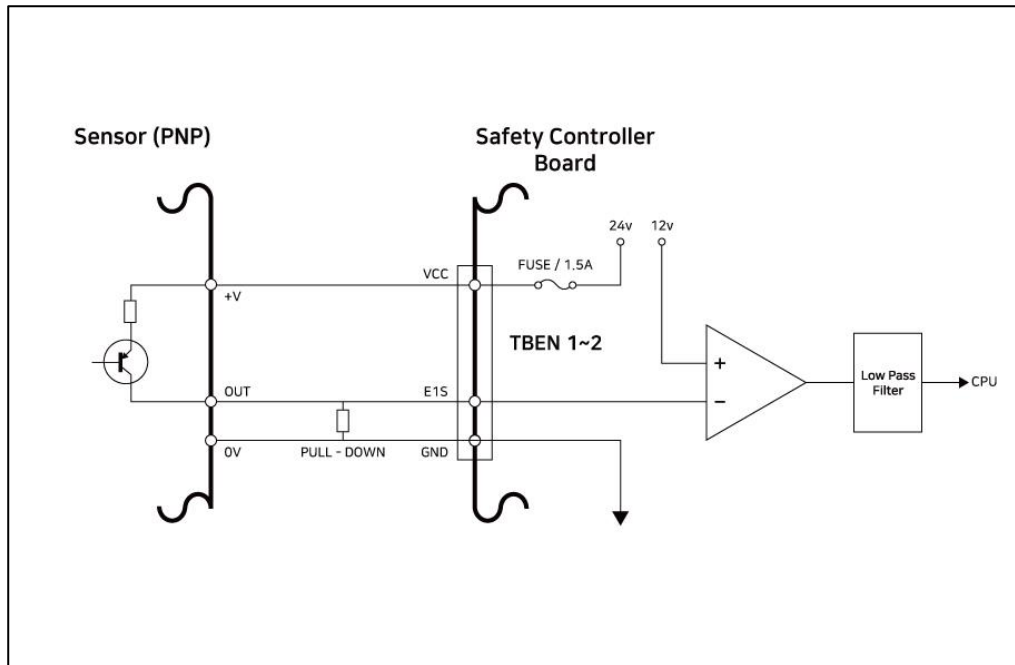

4.3 Network Connection

External Internet, TCP/IP equipment and Modbus equipment can be connected to the network router inside the controller.

Connect cables to dedicated ports according to the network application.

- WAN: Connecting external Internet
- LAN: Connecting peripherals using TCP/IP or Modbus protocol

Connecting the cable to the network connection terminal will connect the network (refer to the figure below).

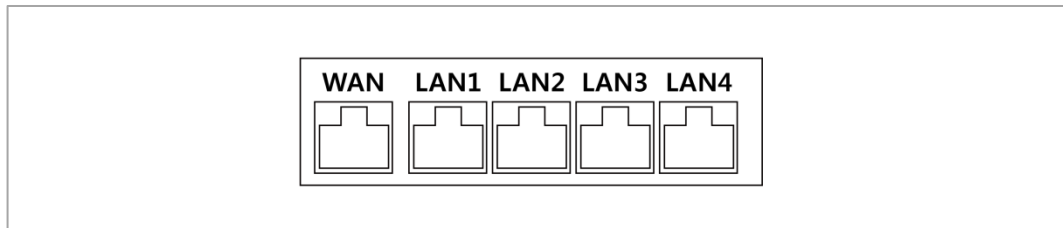

Caution

- The LAN4 port is used to connect internal controllers, so do not connect other equipment.

4.3.1 Connecting External Devices - Vision Sensor

The robot can be connected with a vision sensor (2D camera for object position measurement), and vision sensor measurements can be transferred to the robot through a network to link with commands of the robot.

• Vision Sensor Setting

■ Communication Connection Setting

Connect the LAN ports of the devices and apply TCP/IP communication to transfer vision sensor measurements to the robot. (refer to LAN port connection “**4.3 Network Connection**”) Set the IP address of the vision sensor to TCP/IP 192.168.137.xxx band to allow TCP/IP communication.

■ Vision Work Setting

To perform object position measurement, it is necessary to have an image input and vision teaching of the target object using the vision sensor. Refer to the dedicated vision work setting program provided by the vision sensor manufacturer.

■ Measurement Data Format Setting

To use vision sensor measurement data in robot work, it is necessary to perform vision- robot coordinates calibration, and this must be performed before initiating work using the vision sensor setting program. The vision sensor measurement data must be transferred using the following format settings:

Format	pos	,	x	,	y	,	angle	,	var1	,	var2	,	...
--------	-----	---	---	---	---	---	-------	---	------	---	------	---	-----

- pos: Separator indicating the start of measurement data (prefix)
- x: X coordinate value of the object measured using vision sensor
- y: Y coordinate value of the object measured using vision sensor
- angle: Rotation angle value of the object measured using vision sensor
- var1...varN: Information measured using vision sensor (e.g., object dimension / defect check value)

Example) pos,254.5,-38.1,45.3,1,50.1 (description: x=254.5, y=-38.1, angle=145.3, var1=1, var2=50.1)

• Robot Program Setting

When the physical communication connection between the vision sensor and robot and vision sensor setting are completed, a program must be set to allow the vision sensor and robot program to be linked. It is possible to connect/communication/control functions of the external vision sensor using Doosan Robot Language (DRL), and it is possible to set up the program in the Task Writer.

Details and comprehensive examples of Doosan Robot Language (DRL) on external vision sensor functions are provided in the programming manual.

4.3.2 Connecting External Device – DART Platform

The DART Platform is software that runs on a Windows OS base desktop or laptop. Once you execute the DART Platform after connecting the Controller and desktop/laptop through the LAN Port, all functions of the teach pendant can be used. To establish a connection with sub-controllers within the controller, the following setup procedure is required.

- **IP Address Search and Connection Setting**

- Communication Connection Setting

When a laptop is connected to the LAN port of the controller and the DART Platform is executed, the controller IP address, sub-controller version information and robot serial number required for establishing a connection are automatically searched.

Selecting the serial number of the robot to connect will connect the DART Platform and a sub-controller, allowing the robot to be operated normally.

If there is an issue with the connection, implement the process below. If the issue is not resolved, contact the sales or service staff for assistance.

- If the connectible controller IP address, sub-controller version information and robot serial number search results are not displayed: Press the refresh button to search again and try to connect again according to the procedure above.

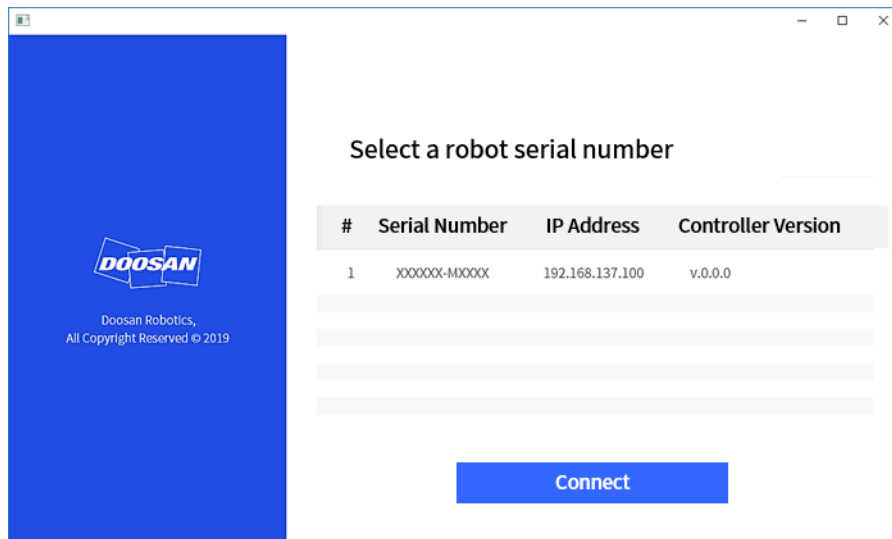

4.3.3 ModbusTCP Slave Setup

The ModbusTCP Slave function of Doosan Robotics supports robot parameter monitoring, and General Purpose Register (GPR) (refer to **4.3.7 Using General Purpose Register (GPR)**) function. This function automatically starts when the robot controller boots up normally. Therefore, the user can use it after matching the Master IP of the robot controller with the same bandwidth.

 **Note**

- The related I/O Table is provided as a separate file.
- Please refer to the Programming Manual for DRL to use the GPR function.

4.3.4 Expanded Protocol - PROFINET IO Device (PNIO device) Setup

The robot controllers of Doosan Robotics support the PROFINET IO Device (Slave) function, which allows data modification after reading the Parameters of the robot from an external device (PROFINET IO Controller/Master). (i.e., robot parameter monitoring, General Purpose Register (Bit, Int, Float) – refer to **4.3.7 Using General Purpose Register (GPR)**). For more information about PROFINET, refer to www.profibus.com.

4.3.5 Expanded Protocol - EtherNet/IP Adapter (EIP adapter) Setup

The robot controllers of Doosan Robotics support the EtherNet/IP Adapter (Slave) function, which allows data modification after reading the Parameters of the robot from an external device (EtherNet/IP Scanner / Master). (i.e., robot parameter monitoring, General Purpose Register (Bit, Int, Float) – refer to **4.3.7 Using General Purpose Register (GPR)**). For more information about EtherNet/IP, refer to www.odva.org.

4.3.6 Using Expanded Protocol

The PROFINET IO Device (PNIO device) and EtherNet/IP Adapter (EIP adapter) functions start together at controller startup, and are in connection standby state with the Master device. Therefore, in order to use the function, it is necessary to connect and set up the Master. Each Master device has different characteristics, so it is necessary to check them.

 **Note**

The following are descriptions of the implementation characteristics of general functions for Industrial Ethernet.

- The Industrial Ethernet function of Doosan Robotics controllers does not use a separate ASIC, but implements its function based on TCP/IP, so it does not support real-time performance.
- Data output to external devices has identical markings (PNIO, EIP), but data input to the robot only has identical structures and does not link. Therefore, data output from the PNIO controller does not synchronize with output data from the EIP scanner.
- For the I/O table of PNIO and EIP, please refer to a separate document (or attachment).

4.3.7 Using General Purpose Register (GPR)

The GPR function is the memory of the PNIO device and the EIP adapter predefined by the user for use. It allows exchange of user data between external devices and the robot.

 **Note**

The GPR function is only provided through DRL, and the DRLs used are as follows: For more information about DRL, please refer to the Programming Manual.

- `set_output_register_bit(address, val)`
- `set_output_register_int(address, val)`
- `set_output_register_float(address, val)`
- `get_output_register_bit(address)`
- `get_output_register_int(address)`
- `get_output_register_float(address)`
- `get_input_register_bit(address)`
- `get_input_register_int(address)`
- `get_input_register_float(address)`

5. Robot Mode and State

The operation modes of the robot consist of Manual Mode where the user controls the robot directly, and Automatic mode where the robot operates without direct user control.

5.1 Manual Mode

This is the mode in which the robot operates according to direct user control. The robot only operates when a button related to an action is pressed, and releasing the button results in stopping the corresponding action.

- In Manual Mode, the TCP movement speed is limited to less than 250 mm/s according to the Robot Safety Regulations. However, during Handguiding, the TCP speed and joint speed are limited to less than the thresholds of Reduced status set in **WCM > Robot > Robot Limits**
- If risk assessment results indicate that a 3-position Enable Switch is necessary, the 3-position Enable Switch can be connected through the I/O by the setting in the **WCM > Robot > Safety I/O**. In this case, the Enable Switch must be placed in the center-enable position to allow robot operation in Manual Mode and Servo On.

In Manual Mode, it is possible to configure robot peripherals in **Workcell Manager** or to program robot tasks in **Task Builder** and **Task Writer**, and if the robot cannot be operated normally for reasons such as the robot exceeding the safety threshold, the Recovery function can be used to restore normal operation.

5.2 Automatic Mode

This is the mode in which the robot operates without direct user control. The robot will execute the programmed task or predefined sequence with a simple operation command and without additional user input.

Task Builder or **Task Writer** can verify the programmed task in virtual mode, execute it in actual operation.

- If risk assessment results indicate that a 3-position Enable Switch is necessary, the 3-position Enable Switch can be connected through the I/O by the setting in the **WCM > Robot > Safety I/O**. In this case, the Enable Switch must be placed in the center-enable position to allow Play or Start, Resume and Servo On in Automatic Mode.

5.3 Other Mode

Unlike normal modes such as manual mode and automatic mode, this is exceptional mode.

This mode includes special states such as controller booting, initializing and states related to Backdrive at which you can push robot by hand without drive power..

5.4 State and Flange LED Color for Each Mode

Mode	State	Description	Flange and/or Base LED
Manual	Manual Standby	<ul style="list-style-type: none"> This is the default status of teaching. Workcell Manager, Task Builder and Task Writer can be used to configure the work condition or perform task programming. It monitors the stop status with Safe Operating Stop (SOS). 	Blue
	Manual Jogging	<ul style="list-style-type: none"> The jog function is used to operate the robot. 	Blue Blinking
	Manual Handguiding	<ul style="list-style-type: none"> The robot can be operated directly by hand during teaching. 	Cyan Blinking
	Recovery Standby	<ul style="list-style-type: none"> Recovery in progress. All safety monitoring functions except for axis and TCP speed monitoring are disabled during recovery. It monitors the stop status with Safe Operating Stop (SOS). 	Yellow Blinking
	Recovery Jogging	<ul style="list-style-type: none"> The jogs of each axis can be used to correct the exceeded safety threshold. 	Yellow Blinking
	Recovery Handguiding	<ul style="list-style-type: none"> The robot can be moved directly by hand to correct the exceeded safety threshold. 	Yellow Blinking
	Safety Stop	<ul style="list-style-type: none"> The system stopped due to protective stop or exceeding the safety threshold. It monitors the stop status with Safe Operating Stop (SOS). 	Yellow

Mode	State	Description	Flange and/or Base LED
Auto	Auto Standby	<ul style="list-style-type: none"> The Teach Pendant UI is in the actual mode execution screen in a single workspace. Pressing the "Execute" button will execute the task program. White is displayed for a Standalone Zone, green is displayed for a Collaborative Zone. 	White/Green
	Auto Running	<ul style="list-style-type: none"> The task program is being executed. White is displayed for a Standalone Zone, green is displayed for a Collaborative Zone, and white and yellow are displayed by turns for a High Priority Zone 	White Blinking / Green Blinking / White and Yellow Flashing alternately
	HGC (HandGuide Control) Standby	<ul style="list-style-type: none"> The Handguiding command is executed during task program execution. The system waits until the user presses the "Handguiding" button. It monitors the stop status with Safe Operating Stop (SOS). 	Cyan
	HGC Running	<ul style="list-style-type: none"> The robot pose can be changed by pressing the "Handguiding" button. After the robot stops, enter HGC End & Resume signal through the Safety IO to set Auto Running and then continue executing the task program. 	Cyan Blinking

Mode	State	Description	Flange and/or Base LED
	Auto-measure	<ul style="list-style-type: none"> The weight and center of gravity point of the end effector are measured automatically. Please note that the safety monitoring functions of the robot are disabled during auto-measuring. 	Yellow Blinking
	Safety Stop	<ul style="list-style-type: none"> The system stopped due to protective stop or exceeding the safety threshold. It monitors the stop status with Safe Operating Stop (SOS). 	Yellow
	Servo Off	<ul style="list-style-type: none"> The servo is off due to protective stop, emergency stop or exceeded safety threshold. It is identical to Safe Torque Off (STO). 	Red (M/H-Series) LED Off (A-Series)

Mode	State	Description	Flange and/or Base LED
	Backdrive Hold	<ul style="list-style-type: none"> All brakes of 6 joints are engaged, and Backdrive motion is locked. 	Yellow Blinking
	Backdrive Release	<ul style="list-style-type: none"> Break of one or more joint(s) is released due to the selection of brake release. The brake(s) will not lock by itself. Use caution as the robot and/or end-effector may fall unless all brakes are engaged again. 	Yellow Blinking
	Backdrive Servo Off	<ul style="list-style-type: none"> The servo is off due to emergency stop or exceeded joint speed threshold during Backdrive Motion. It is identical to Safe Torque Off (STO). 	Red (M/H-Series) LED Off (A-Series)
	Initializing	<ul style="list-style-type: none"> The controller is booting and the robot is initialized. 	Red Blinking

6. Safety Functions

6.1 Introduction

Robot's from Doosan Robotics uses various safety-rated monitoring and safety-related electrical interfaces to protect users and devices, and this allows the integration of other devices and additional protection devices. The performance of each safety-rated monitoring and interface satisfies Category 3, Performance Level d(PL d) defined by ISO 13849-1 and Hardware Fault Tolerance 1, Safety Integrity Level 2 (SIL 2) defined by IEC 62061.

Note

- Work cells must be set using safety functions and the interface according to the risk assessment performed on the corresponding robot application by the system integrator, and refer to this manual for information required for this.
- If the safety systems of the robot detect system defects such as hardware defects including emergency stop circuit shortage, position sensor damage or control communication error, stop category 0 is immediately initiated. Meanwhile, if the safety systems of the robot detect violations during safety monitoring, such as pressing the emergency stop switch, protective stop signal input, detection of external impact, or physical parameters (robot position, speed, momentum) exceeding set parameters, the system stops the robot using the mode set to the stop mode setting in the safety setting menu. (select one from stop category 0, 1, 2)
- In special cases (collision detection, TCP Force Violation), a special mode that stops the robot after accepting the external force for 0.25 seconds from the time of event occurrence can be used to avoid clamping situations where a person's limbs are jammed between the fixed jig/workpiece and the robot. (RS1 stop mode)
- For information on time and stopping distance from the moment the above error or violation occurs until the robot comes to a complete stop, refer to **Annex C Stop Distance and Stop Time**. This time must be considered as part of the risk assessment performed by the system integrator.
- The safety setting menu can set various safety functions to limit the movement of joints, robot and TCP. Here, TCP means the location of the output flange center point added by the TCP offset.

6.2 Safety-Rated Stop Function

This is the stop function and stop monitoring function of Doosan Robotics, and it uses the safety function defined in IEC 61800-5-2.

Safety Function Name	Function Description and Failure Detection	PFHd	PL, SIL
STO (Safe Torque Off)	Immediately cuts off the power supply to all joint module motors, and brake engagement forces the operation to stop. (Servo Off)	2.54E-8 /h	PL e Cat. 4 SIL 3
SS1 (Safe Stop 1)	All joints are stopped with the maximum deceleration possible, the power supply to the motor is cut off, and the brake is engaged to stop. (Servo Off) If deceleration is not sufficient during stopping, the method is set to STO stop.	1.41E-7 /h	PL d Cat. 3 SIL 2
SS2 (Safe Stop 2)	All joints are stopped with the maximum deceleration possible, and the SOS stop monitoring function is set. If deceleration is not sufficient during stopping, the method is set to STO stop.	1.41E-7 /h	PL d Cat. 3 SIL 2
SOS (Safe Operating Stop)	The current position is maintained with power supplied to the motor and the brake disengaged (Servo ON). STO is set if abnormal position change is detected.	1.41E-7 /h	PL d Cat. 3 SIL 2

Safety Function Name	Stop Triggering Event	Stop Mode	PFHd	PL, SIL
Emergency Stop	If the Emergency Stop switch of TP is pressed If the Emergency Stop switch connected to the TBSFT EM terminal is pressed	STO or SS1	2.54E-8 /h	PL e Cat. 4 SIL 3
Protective Stop	If the protective device connected to the TBSFT PR terminal is activated	STO, SS1 or SS2	1.41E-7 /h	PL d Cat. 3 SIL 2

6.2.1 Emergency Stop Function

The user can use the emergency stop button to stop the system in emergency situations. In emergency situations, press the Emergency Stop button in the top right corner of the teach pendant to immediately stop the system.

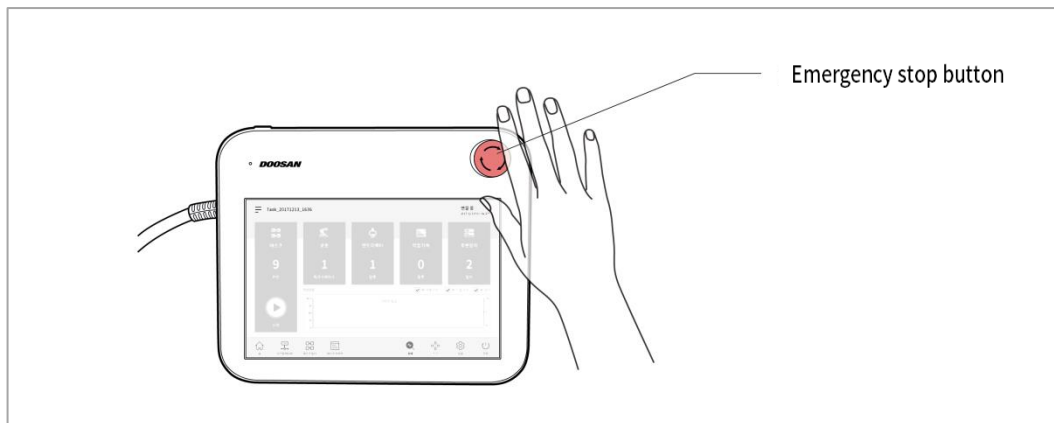

Note

- The SS1 stop mode is set to the default setting of the emergency stop button.
- Turning the emergency stop button clockwise turns off the emergency stop function.
- If additional Emergency Stop buttons are needed, a button can be added to the controller after a risk assessment.
- Emergency stop must not be used as a risk reduction method, but as a secondary protection device.
- If additional emergency stop buttons must be connected, this must be determined with a robot application risk assessment. The Emergency Stop button must comply with IEC 60947-5-5.

6.2.2 Protective Stop

The robot is equipped with a protective stop function to stop the robot according to signals sent by protective devices.

For information about protective device connection, refer to sections **4.2.1 Setting the Terminal Block for Contact Input (TBSFT)** and **4.2.4 Setting the Configurable Digital I/O (TBCI1 - 4,TBCO1 - 4)**.

6.3 Safety Rated Monitoring Function

Doosan robot's feature various safety rated monitoring functions that can be used as a risk reduction measure through risk assessment. The limits detected by each monitoring function can be set under robot > robot Limits in the Teach Pendant UI WCM.

- Joint Position Monitoring (SLP): Limits the maximum rotation angle of a joint
- Joint Speed Monitoring (SLS): Limits the maximum rotation speed of a joint
- TCP Position/Direction Monitoring:
Limits and monitors TCP position/direction in an orthogonal space
Operating Space, Standalone Workspace, Collaborative Workspace, Protected Zone,
Tool orientation limit zone, collision detection mute zone
- TCP Speed Monitoring: Limits the maximum TCP movement speed of TCP
- TCP External Force Monitoring: Limits the external force applied to TCP
- Collision Detection: Limits the external torque applied to the Manipulator arm and each joint
- Momentum Monitoring: Limits the maximum momentum of the Manipulator arm
- Mechanical Power Monitoring: Limits the maximum power applied to the Manipulator arm.

Note

- The safety limits used by each monitoring function can be set under robot > robot Limits in the Teach Pendant UI.
- Safety limits is the condition where the safety rated monitoring function triggers the stop function. When stop is completed, the position of the robot and force applied externally may differ from the configured safety threshold.

Safety Function Name	Stop Triggering Event	Stop Mode	PFHd	PL, SIL
Joint Position Limit (SLP)	If the angle of each axis exceeds the configured threshold	STO, SS1 or SS2	1.41E-7 /h	PL d Cat. 3 SIL 2
Joint Speed Limit (SLS)	If the speed of each axis exceeds the configured threshold	STO, SS1 or SS2	1.41E-7 /h	PL d Cat. 3 SIL 2
Joint Torque Limit (SLT)	If the torque applied to each axis exceeds the predefined threshold	STO	1.94E-7 /h	PL d Cat. 3 SIL 2
Collision Detection	If the torque applied to each axis exceeds the thresholds for the configured sensitivity	STO, SS1 or SS2	1.94E-7 /h	PL d Cat. 3 SIL 2
TCP/Robot Position Limit	If the TCP/Robot leaves the operating space If the TCP enters the protected space	STO, SS1 or SS2	1.41E-7 /h	PL d Cat. 3 SIL 2

Safety Function Name	Stop Triggering Event	Stop Mode	PFHd	PL, SIL
TCP Orientation Limit	If the difference between the set direction within the Tool Orientation Limit Zone and the TCP orientation deviation exceeds the configured threshold	STO, SS1 or SS2	1.41E-7 /h	PL d Cat. 3 SIL 2
TCP Speed Limit	If the TCP speed exceeds the configured threshold	STO, SS1 or SS2	1.41E-7 /h	PL d Cat. 3 SIL 2
TCP Force Limit	If the external force applied to the TCP exceeds the configured threshold	STO, SS1 or SS2	1.94E-7 /h	PL d Cat. 3 SIL 2
Robot Momentum Limit	If the momentum of the robot exceeds the configured threshold	STO, SS1 or SS2	1.41E-7 /h	PL d Cat. 3 SIL 2
Robot Power Limit	If the mechanical power of the robot exceeds the configured threshold	STO, SS1 or SS2	1.94E-7 /h	PL d Cat. 3 SIL 2

6.4 Safety-Rated I/O

The robot's of Doosan Robotics feature a safety-rated input interface capable of connecting protective stop signals from safety protective devices, external emergency stop signal input and 3-position Enable Switch. They also feature a safety-rated output interface capable of outputting internal status and area information.

Safety Function Name	Function Description and Failure Detection	PFHd	PL, SIL
Safety IO	It is a duplexed interface for safety related signal input and output If the input signals do not match or if duplexed output signal feedbacks do not match, it stops the robot and displays an error message.	2.7E-8 /h	PL d Cat. 3 SIL 2

7. Transportation

7.1 Caution during Transportation



Caution

- If the robot is wrapped in packaging materials and transported, store the robot in a dry location. If the robot is stored in a location with high humidity, condensation may occur inside the packaging material, resulting in robot defects.
- When relocating the robot, consider the weight of the robot's link or base and carry the robot with sufficient personnel at the same time. Especially for H-series, refer to the "Handling Guide" and make sure to carry it in accordance with the safety regulations of the country.
- The controller is moved by grasping the bottom handle.
- When transporting the robot or controller, make sure to maintain the proper posture. Failure to do so may result in back injury or other physical injuries.
- When transporting the robot using lifting equipment, make sure to observe all related national and regional regulations.
- Doosan Robotics does not assume responsibility for any damages or losses that occur during transportation, so make sure to transport the robot safely according to the user manual.

7.2 Pose for Robot Transportation

Set the following poses to transport the robot:

Model	J1	J2	J3	J4	J5	J6
M0607	0°	0°	150°	0°	25°	0°
M0617	0°	0°	165°	0°	15°	0°
M1013	0°	0°	160°	0°	20°	0°
M1509	0°	0°	150°	0°	25°	0°
H2017	0°	0°	160°	0°	15°	0°
H2515	0°	0°	160°	0°	15°	0°

7.3 Package Specifications

The box specifications for transport are as follows:

Model	Length	Width	Height
M0607	742 mm	500 mm	400 mm
M0617	1194 mm	500 mm	435 mm
M1013	968 mm	500 mm	435 mm
M1509	742 mm	500 mm	400 mm
H2017	1040mm	1040mm	1585mm
H2515	1040mm	1040mm	1500mm

8. Maintenance

System maintenance must be performed by Doosan Robotics or a company designated by Doosan Robotics. Maintenance is intended to keep the system operable or to return the system to an operable state in the event of a problem, and it includes repair work as well as system diagnosis of potential issues.

When maintenance work is completed, risk assessment must be performed to confirm whether the system satisfies required safety levels. Corresponding national and regional regulations must be observed during inspection, and all possibilities related to safety must be tested.

When performing work on the manipulator or controller, the following safety procedures and warnings must be observed.

- Maintain the safety settings of the software during maintenance work.
- If a particular part is defective, replace it with a new identical part or part approved by Doosan Robotics.
- The replaced part must be returned to Doosan Robotics.
- After completing the work, resume the safety function.
- Document the repair history of the robot system and manage related technical documents.
- Disconnect the power cable and make sure other power sources connected to the manipulator or controller do not supply power.
- Do not connect the system to a power source during maintenance.
- Check the ground connection before supplying power to the system.
- When disassembling the manipulator or controller parts, observe ESD regulations.
- Do not disassemble areas that supply power within the controller. Power supply areas may still be charged with high voltage (up to 600V) even after the controller is turned off.
- Take caution to prevent water or dust from entering the system during maintenance.

9. Disposal and Environment

Since this system contains industrial waste materials, improper disposal can cause environmental pollution. Therefore, do not dispose of the system along with general industrial or household waste.

When disposing of all or part of the system, the relevant laws and legislation must be complied with, and contact Doosan Robotics for detailed information related to the disposal of the system.

10. Product Warranty and Responsibility

Doosan Robotics (hereinafter referred to as “Doosan” or “Manufacturer”) offers a restricted warranty as stipulated in this warranty certificate for all robot systems (collectively “robot”) and parts of the system (excluding parts that are exceptions or restricted according to the terms and conditions below) sold through Doosan or official sales agents. The warranty stipulated by this warranty certificate is a restricted warranty, and it is the only warranty provided by the Manufacturer. All warranty items shall be handled according to the conditions listed below.

10.1 Scope of Warranty

The material and manufacturing defects of each robot and its parts (collectively, “Doosan Products”) are subject to the warranty provided by the Manufacturer. This warranty is only offered to the end user (hereinafter referred to as “Customer”). The warranty period is 1 year starting from the date when the robot was installed.

The scope of this warranty limits the Manufacturer's only responsibility for all Doosan products and the Customer's only remedy to the repair or replacement of defective Doosan products.

Doosan does not compensate any or all financial, operation or productions losses, any or all indirect losses such as damage to other equipment, and any or all deliberate, special or consequential losses that occur due to defects of Doosan Products.

10.2 Restrictions and Exceptions of Warranty

To maintain the warranty, thorough maintenance procedures stipulated by the Manufacturer must be observed and recorded. This warranty is voided if the Manufacturer determines that the user failed to observe the following stipulated procedures.

- If a Doosan Product is inappropriately handled or used by the user
- If parts or S/W not provided by Doosan are installed
- If a Doosan Product is incorrectly repaired or maintained by an unofficial repair technician or unauthorized individuals
- If the user modified a Doosan Product without prior approval from the Manufacturer
- If a Doosan Product was used for non-industrial or personal purposes
- If the life cycle of consumables has ended
- If the warranty claim is made after the warranty period
- If the breakdown is caused by natural disasters (fire, flood, abnormal power, etc.)

This warranty does not apply to damages caused by external circumstances the Manufacturer does not have any control over such as theft, intentional destruction, fire, natural disasters, war or act of terrorism.

Notwithstanding the exceptions or restrictions of this warranty, this warranty does not include any warranties where a Doosan Product satisfies the buyer's production standards or miscellaneous requirements, or operates without any errors or without any interruption. The Manufacturer does not assume responsibility for any uses by the buyer, and the Manufacturer does not assume any responsibility for defects other than repair or replacement such as defects in design, production, operation and performance.

10.3 Transfer

This warranty is included in the warranty period, and if the Doosan robot is sold to a different individual through a private transaction, the warranty can also be transferred. However, the warranty is only valid if the Manufacturer is notified of this transaction, and the warranty period is still in effect. The assignee of this warranty must observe all conditions stipulated in this warranty.

11. Indemnification

Doosan Robotics continues to upgrade product reliability and performance, and Doosan Robotics has the right to upgrade the product without notification. Doosan Robotics endeavors to ensure that all contents in this manual are accurate. However, it does not assume responsibility for errors or missing information.

Annex A System Specification

A.1 Manipulator

A.1.1 M0609

Classification	Item	Specification
Performance	Axis Structure	6
	Payload	6 kg
	Max. Radius	900 mm
	TCP Speed	1 m/s
	Repeatability	± 0.05 mm
Joint Movement	J1 Range / Speed	±360° / 150°/s
	J2 Range / Speed	±360° / 150°/s
	J3 Range / Speed	±150° / 180°/s
	J4 Range / Speed	±360° / 225°/s
	J5 Range / Speed	±360° / 225°/s
	J6 Range / Speed	±360° / 225°/s
Operating Environment	Operating Temperature	0 - 45 °C (273K-318K)
	Storage Temperature	-5 - 50 °C (268K-323K)
	Humidity	20-80%
Tool Flange & Connector	Digital I/O - X1	IN-3ch / Out-3ch
	Digital I/O – X2	IN-3ch / Out-3ch
	Power Supply	DC 24V/ Max. 3A
	Connector	1414229 (PHOENIX)
Cable	Teach Pendant-Controller (4.5 m) / Controller – Robot (6.0 m)	
Weight	27 kg	
Mounting	Floor, Ceiling, Wall	
IP Rating	IP 54	
Noise	< 65 dB	

A.1.2 M1509

Classification	Item	Specification
Performance	Axis Structure	6
	Payload	15 kg
	Max. Radius	900 mm
	TCP Speed	1 m/s
	Repeatability	± 0.05 mm
Joint Movement	J1 Range / Speed	±360° / 150°/s
	J2 Range / Speed	±360° / 150°/s
	J3 Range / Speed	±150° / 180°/s
	J4 Range / Speed	±360° / 225°/s
	J5 Range / Speed	±360° / 225°/s
	J6 Range / Speed	±360° / 225°/s
Operating Environment	Operating Temperature	0 - 45 °C (273K-318K)
	Storage Temperature	-5 - 50 °C (268K-323K)
	Humidity	20-80%
Tool Flange & Connector	Digital I/O - X1	IN-3ch / Out-3ch
	Digital I/O - X2	IN-3ch / Out-3ch
	Power Supply	DC 24V/ Max. 3A
	Connector	1414229 (PHOENIX)
Cable		Teach Pendant (4.5 m) / Robot (6.0 m)
Weight		32 kg
Mounting		Floor, Ceiling, Wall
IP Rating		IP 54
Noise		< 65 dB

A.1.3 M1013

Classification	Item	Specification
Performance	Axis Structure	6
	Payload	10 kg
	Max. Radius	1300 mm
	TCP Speed	1 m/s
	Repeatability	± 0.05 mm
Joint Movement	J1 Range / Speed	±360° / 120°/s
	J2 Range / Speed	±360° / 120°/s
	J3 Range / Speed	±160° / 180°/s
	J4 Range / Speed	±360° / 225°/s
	J5 Range / Speed	±360° / 225°/s
	J6 Range / Speed	±360° / 225°/s
Operating Environment	Operating Temperature	0 - 45 °C (273K-318K)
	Storage Temperature	-5 - 50 °C (268K-323K)
	Humidity	20-80%
Tool Flange & Connector	Digital I/O - X1	IN-3ch / Out-3ch
	Digital I/O – X2	IN-3ch / Out-3ch
	Power Supply	DC 24V/ Max. 3A
	Connector	1414229 (PHOENIX)
Weight		33 kg
Mounting		Floor, Ceiling, Wall
IP Rating		IP 54
Noise		< 65 dB

A.1.4 M0617

Classification	Item	Specification
Performance	Axis Structure	6
	Payload	6 kg
	Max. Radius	1700 mm
	TCP Speed	1 m/s
	Repeatability	± 0.1 mm
Joint Movement	J1 Range / Speed	±360° / 100°/s
	J2 Range / Speed	±360° / 100°/s
	J3 Range / Speed	±165° / 150°/s
	J4 Range / Speed	±360° / 225°/s
	J5 Range / Speed	±360° / 225°/s
	J6 Range / Speed	±360° / 225°/s
Operating Environment	Operating Temperature	0 - 45 °C (273K-318K)
	Storage Temperature	-5 - 50 °C (268K-323K)
	Humidity	20-80%
Tool Flange & Connector	Digital I/O - X1	IN-3ch / Out-3ch
	Digital I/O - X2	IN-3ch / Out-3ch
	Power Supply	DC 24V/ Max. 3A
	Connector	1414229 (PHOENIX)
Weight		34 kg
Mounting		Floor, Ceiling, Wall
IP Rating		IP 54
Noise		< 65 dB

A.1.5 H2017

Classification	Item	Specification
Performance	Axis Structure	6
	Payload	20 kg
	Max. Radius	1700 mm
	TCP Speed	1m/s
	Repeatability	± 0.1mm
Joint Movement	J1 Range / Speed	±360° / 100°/s
	J2 Range / Speed	±130° / 80°/s
	J3 Range / Speed	±160° / 100°/s
	J4 Range / Speed	±360° / 180°/s
	J5 Range / Speed	±360° / 180°/s
	J6 Range / Speed	±360° / 180°/s
Operating Environment	Operating Temperature	0 °C to 45 °C (273 K to 318 K)
	Storage Temperature	-5 °C to 50 °C (268 K to 323 K)
	Humidity	20 % to 80 %
Tool Flange & Connector	Digital I/O - X1	IN-3ch / Out-3ch
	Digital I/O – X2	IN-3ch / Out-3ch
	Power Supply	DC 24V/ Max. 3A
	Connector	1414229 (PHOENIX)
Weight		74 kg
Mounting		Floor
IP Rating		IP 54
Noise		< 65 dB

A.1.6 H2515

Classification	Item	Specification
Performance	Axis Structure	6
	Payload	25 kg
	Max. Radius	1500 mm
	TCP Speed	1m/s
	Repeatability	± 0.1mm
Joint Movement	J1 Range / Speed	±360° / 100°/s
	J2 Range / Speed	±130° / 80°/s
	J3 Range / Speed	±160° / 100°/s
	J4 Range / Speed	±360° / 180°/s
	J5 Range / Speed	±360° / 180°/s
	J6 Range / Speed	±360° / 180°/s
Operating Environment	Operating Temperature	0 °C to 45 °C (273 K to 318 K)
	Storage Temperature	-5 °C to 50 °C (268 K to 323 K)
	Humidity	20 % to 80 %
Tool Flange & Connector	Digital I/O - X1	IN-3ch / Out-3ch
	Digital I/O - X2	IN-3ch / Out-3ch
	Power Supply	DC 24V/ Max. 3A
	Connector	1414229 (PHOENIX)
Weight		72 kg
Mounting		Floor
IP Rating		IP 54
Noise		< 65 dB

A.2 Controller

A.2.1 CS-01 (AC Controller)

Item	Specification
Weight	13 kg
Dimensions	490 x 390 x 252 mm
Protection Rating	IP30
Interfaces	Ethernet / USB / RS-232
I/O Port – Digital I/O	16/16
I/O Port – Analog I/O	2/2
I/O power supply	DC 24V
Industrial Network	ModbusTCP Master/Slave, ModbusRTU Master, PROFINET IO Device, EtherNet/IP Adapter
Rated supply voltage	100-240VAC 47-63Hz
Cable Length	TP Cable: 4.5 m (Option: 2.5 m) Robot Cable: 6 m (Option: 3 m / 12 m)

A.2.2 CS-02 (DC Controller)

Item	Specification
Weight	12 kg
Dimensions	462 x 290 x 216 mm
Protection Rating	IP20
Interfaces	Ethernet / USB / RS-232
I/O Port – Digital I/O	16/16
I/O Port – Analog I/O	2/2
I/O power supply	DC 24V
Industrial Network	ModbusTCP Master/Slave, ModbusRTU Master, PROFINET IO Device, EtherNet/IP Adapter
Rated supply voltage	22-60 VDC
Cable Length	TP Cable: 2.5 m (Option: 4.5 m) Robot Cable: 3 m (Option: 6 m)

A.2.3 CS-01P (AC Controller)

Item	Specification
Weight	17 kg
Dimensions	515 x 240 x 395 mm
Protection Rating	IP54
Interfaces	Ethernet / USB / RS-232
I/O Port – Digital I/O	16/16
I/O Port – Analog I/O	2/2
I/O power supply	DC 24V
Industrial Network	ModbusTCP Master/Slave, ModbusRTU Master, PROFINET IO Device, EtherNet/IP Adapter
Rated supply voltage	100-240VAC 47-63Hz
Cable Length	TP Cable: 4.5 m (Option: 2.5 m) Robot Cable: 6 m (Option: 3 m / 12 m)

A.3 Teach pendant

A.3.1 TP-01

Item	Specification
Weight	0.8 kg
Dimensions	264 x 218 x 42 mm
Protection Rating	IP40
Screen Size	10.1 inch i
Cable Length	4.5 m (Option: 2.5 m)

A.4 DART Platform Installation Requirement (minimum, recommended)

The minimum installation requirements for the DART Platform are as follows:



- OS: Windows 7 Enterprise Service pack1 (64 bit) or higher
- CPU: 2.20 GHz or higher
- GPU: GMA 4500 and GMA HD (Intel) or equivalent specification
- Memory: 4 GB
- Java SDK: jdk1.8.0_152 (64 bit)

The recommended installation requirements for the DART Platform are as follows:

- OS: Windows 10 Enterprise (64 bit)
- CPU: 2.80 GHz or higher
- GPU: GMA 4500 higher and GMA HD (Intel) higher
- Memory: 16 GB
- Java SDK: jdk1.8.0_152 (64 bit)

Annex B Declaration and Certification

B.1 Europe Declaration of Incorporation (Original)

DECLARATION OF INCORPORATION	
according to EC Machinery Directive 2006/42/EC Annex II Part 1 Section B	
We,	Doosan Robotics Inc. 79, Saneop-ro 156beon-gil, Gwonseon-gu, Suwon-si, Gyeonggi-do, 16648, Republic of Korea
<i>declare under our sole responsibility that the following product:</i>	
Product :	Industrial Robot (Manipulator & Controller)
Model :	Manipulator : M0609, M1509, M1013, M0617 Controller : CS-01
<i>is in conformity with the following standard(s) or other normative document(s)</i>	
Standard	Description
EN ISO 12100:20100	Safety of machinery General principles for design Risk assessment and risk reduction
EN ISO 10218-1	Robots and robotic devices - Safety requirements for industrial robots Part 1: Robots
EN 60204-1:2006/A1:2009	Safety of machinery Electrical equipment of machines Part 1: General requirements
<i>The product as the partly completed machinery must not be put into service until the final machinery into which it is to be incorporated has been declared in conformity with the provisions of the Directive 2006/42/EC, as amended by Directive 2009/127/EC, and with the regulations transposing it into national law.</i>	
<i>Relevant technical documentations are compiled in accordance with Annex VII, part B of the Directive, and available in electronic form to national authorities upon legitimate request.</i>	
<i>Additionally the product declares in conformity with the following directives, according to which the product is CE marked:</i>	
2014/35/EU	Low Voltage Directive (LVD)
2014/30/EU	Electromagnetic Compatibility Directive (EMC)
Suwon, 15 th October, 2018 R&D Center	 Junhyun Jang Chief Technical Officer
	

B.2 Europe Machinery Directive Attestation of Conformity

ZERTIFIKAT ◆ CERTIFICATE ◆ 認證書 ◆ CERTIFICADO ◆ CERTIFICAT



Product Service

Attestation of Conformity

No. M8A 004249 0031 Rev. 00

Holder of Certificate: Doosan Robotics Inc
79, Saneop-ro 156beon-gil, Gwonseon-gu
Suwon-si, Gyeonggi-do 16648
REPUBLIC OF KOREA

**Product: Industrial Robot
(Manipulator & Controller)**

This Attestation of Conformity is issued on a voluntary basis according to Council Directive 2006/42/EC relating to machinery. It confirms that the listed equipment (not Annex IV equipment) complies with the principal protection requirements of the directive. It refers only to the sample submitted to TÜV SÜD Product Service GmbH for testing and certification. For details see: www.tuvsud.com/ps-cert

Test report no.: MAEB01217420

Date, 2020-07-30

(Ro-Hyun Park)

Page 1 of 2

After preparation of the necessary technical documentation as well as the EC declaration of conformity the required CE marking can be affixed on the product. Other relevant directives have to be observed.

TÜV SÜD Product Service GmbH • Certification Body • Riderstraße 65 • 80339 Munich • Germany

TUV®



Product Service

Attestation of Conformity

No. M8A 004249 0031 Rev. 00

Model(s): Manipulator : M0609, M0617, M1013, M1509, H2017, H2515
Controller : CS-01, CS-01P, CS-02

Parameters:	Manipulator:	M0609	M0617	M1013	M1509
	Payload:	6 kg	6 kg	10 kg	15 kg
	Degrees of freedom:	6 Axis	6 Axis	6 Axis	6 Axis
	Weight:	27 kg	34 kg	33 kg	32 kg
		H2017	H2515		
		20 kg	25 kg		
		6 Axis	6 Axis		
		74 kg	72 kg		
	Controller:	CS-01	CS-01P	CS-02	
	Rated Input voltage:	100-240 V a.c., 1 Phase	100-240 V a.c., 1 Phase	22-60 V d.c.	
	Rated frequency:	50/60 Hz	50/60 Hz	N/A	
	Weight:	13 kg	17 kg	12 kg	

Tested according to: EN ISO 10218-1:2011
EN ISO 12100:2010
EN 60204-1:2006/A1:2009

Page 2 of 2

After preparation of the necessary technical documentation as well as the EC declaration of conformity the required CE marking can be affixed on the product. Other relevant directives have to be observed.

TÜV SÜD Product Service GmbH • Certification Body • Ridlerstraße 65 • 80339 Munich • Germany

TUV®

B.3 Europe EMC Directive Attestation of Conformity

ZERTIFIKAT ◆ CERTIFICATE ◆ 認證證書 ◆ CERTIFICADO ◆ CERTIFICAT



Product Service

Attestation of Conformity

No. E8A 004249 0033 Rev. 00

Holder of Certificate: Doosan Robotics Inc
79, Saneop-ro 156beon-gil, Gwonseon-gu
Suwon-si, Gyeonggi-do 16648
REPUBLIC OF KOREA

Name of Object: Industrial Robot
(Manipulator & Controller)

Model(s): Manipulator: M0609, M0617, M1013, M1509, H2017, H2515
Controller: CS-01, CS-01P, CS-02

Description of Object:

Rated input voltage:	CS-01 100-240 V a.c., 1 Phase
Rated input frequency:	50/60 Hz
Rated input voltage:	CS-01P 100-240 V a.c., 1 Phase
Rated input frequency:	50/60 Hz
Rated input voltage:	CS-02 22-60 V d.c.

Tested according to: EN 61000-6-4:2007/A1:2011
EN 61000-6-2:2005
EN 61000-3-2:2014
EN 61000-3-3:2013

This Attestation of Conformity is issued on a voluntary basis according to the Directive 2014/30/EU relating to electromagnetic compatibility. It confirms that the listed apparatus complies with all essential requirements of the directive and is based on the technical specifications applicable at the time of issuance. It refers only to the particular sample submitted for testing and certification. For details see: www.tuvsud.com/ps-cert

Test report no.: CPSC01387620

Date, 2020-08-26

(Byung-Soo Kang)

Page 1 of 1

After preparation of the necessary technical documentation as well as the EU Declaration of conformity the required CE marking can be affixed on the product. That Declaration of conformity is issued under the sole responsibility of the manufacturer. Other relevant EU-directives have to be observed.

TÜV SÜD Product Service GmbH • Certification Body • Ridlerstraße 65 • 80339 Munich • Germany

TUV®

B.4 U.S. NRTL Certification (U.S., CANADA)

ZERTIFIKAT ◆ CERTIFICATE ◆ 認證書 ◆ CERTIFICADO ◆ CERTIFICAT



CERTIFICATE

No. U8 004249 0032 Rev. 00

Holder of Certificate: **Doosan Robotics Inc**
79, Saneop-ro 156beon-gil, Gwonseon-gu
Suwon-si, Gyeonggi-do 16648
REPUBLIC OF KOREA

Certification Mark:



Product: **Industrial Robot
(Manipulator & Controller)**

This product was voluntarily tested to the relevant safety requirements referenced on this certificate. It can be marked with the certification mark above. The mark must not be altered in any way. This product certification system operated by TÜV SÜD America Inc. most closely resembles system 3 as defined in ISO/IEC 17067. Certification is based on the TÜV SÜD "Testing and Certification Regulations". TÜV SÜD America Inc. is an OSHA recognized NRTL and a Standards Council of Canada accredited Certification body.

Test report no.: MAEA07220420

Date, 2020-07-30

(Ro-Hyun Park)



CERTIFICATE

No. U8 004249 0032 Rev. 00

Model(s): Manipulator : M0609, M0617, M1013, M1509, H2017, H2515
 Controller : CS-01, CS-01P, CS-02

Tested according to: UL 1740:2007/R:2015-01
 CAN/CSA-Z434:2014/R:2019

Production Facility(ies): 004249

Parameters:	Manipulator:	M0609	M0617	M1013	M1509
	Payload:	6 kg	6 kg	10 kg	15 kg
	Degrees of freedom:	6 Axis	6 Axis	6 Axis	6 Axis
	Weight:	27 kg	34 kg	33 kg	32 kg
		H2017	H2515		
		20 kg	25 kg		
		6 Axis	6 Axis		
		74 kg	72 kg		
	Controller:	CS-01	CS-01P	CS-02	
	Rated input voltage:	100-240 V a.c., 1 Phase	100-240 V a.c., 1 Phase	22-60 V d.c.	
	Rated frequency:	50/60 Hz	50/60 Hz	N/A	
	Weight:	13 kg	17 kg	12 kg	

Additionally tested to: ANSI/NFPA 79:2015

B.5 Functional Safety Certification

TÜV SÜD
 ZERTIFIKAT ◆ CERTIFICATE ◆ 認證證書 ◆ CERTIFICADO ◆ CERTIFIKAT ◆ CERTIFICATE

A4 / 07.17



Product Service

CERTIFICATE

No. Z10 004249 0013 Rev. 00

Holder of Certificate: Doosan Robotics Inc
 79, Saneop-ro 156beon-gil, Gwonseon-gu
 Suwon-si 16648
 REPUBLIC OF KOREA

Factory(ies): 004249



Product: Robot Safety Unit
Model(s): Doosan Robotics Safety Controller

Parameters: Safety functions:
 STO, SBC, Emergency Stop: **SIL3, SIL CL3, PL e CAT4**
 SS1, SS2, SOS, SLP, SLS, SLT, Protective Stop,
 TCP/Robot Position Limit, TCP Orientation Limit, TCP Speed Limit,
 TCP Force Limit, Robot Momentum Limit, Robot Power Limit,
 Collision Detection, Safety I/O: **SIL2, SIL CL2, PL d CAT3**

Tested according to: IEC 61508-1:2010
 IEC 61508-2:2010
 IEC 61508-3:2010
 IEC 61508-4:2010
 IEC 61800-5-1:2007
 IEC 61800-5-2:2016
 ISO 13849-1:2015
 IEC 62061:2005
 IEC 62061:2005/AMD1:2012
 IEC 62061:2005/AMD2:2015
 ISO 10218-1:2011
 ISO TS 15066:2016
 IEC 61000-6-7:2014
 IEC 61326-3-1:2017

The product was tested on a voluntary basis and complies with the essential requirements. The certification mark shown above can be affixed on the product. It is not permitted to alter the certification mark in any way. In addition the certification holder must not transfer the certificate to third parties. See also notes overleaf.

Test report no.: DS93146T
Valid until: 2024-01-27

Date, 2019-01-30 
 (Guido Neumann)



B.6 Voluntary Safety Confirmation Declaration (KCs)



자율안전확인 신고증명서

신청인	사업장명	두산로보틱스주식회사	사업장관리번호	257-88-001280
	사업자등록번호	257-88-00128	대표자 성명	이병서
	소재지	(16648) 경기도 수원시 권선구 산업로156번길 79		
자율안전인증대상 기계·기구명		산업용로봇		
형식(규격)	M0609	용량(등급)	6 axis	
자율안전 확인번호		17-AB1EQ-01516		
제조사	두산로보틱스주식회사			
소재지	(16648) 경기도 수원시 권선구 산업로156번길 79			

「산업안전보건법」 제35조제1항 및 같은 법 시행규칙 제61조제3항에 따라
자율안전확인 신고증명서를 발급합니다.

2017년 12월 05일



한국산업안전보건공단 서울지역본부장

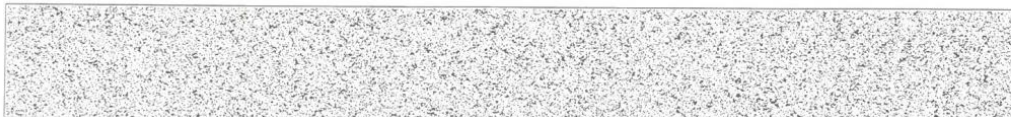



자율안전확인 신고증명서

신청인	사업장명	두산로보틱스 주식회사	사업장관리번호	257-88-001280
	사업자등록번호	257-88-00128	대표자 성명	이병서
	소재지	(16648) 경기도 수원시 권선구 산업로156번길 79		
자율안전인증대상 기계·기구명		산업용로봇		
형식(규격)	M1509	용량(등급)	6 axis	
자율안전확인번호	18-AB1EQ-00589			
제조사	두산로보틱스주식회사			
소재지	(16648) 경기도 수원시 권선구 산업로156번길 79			

「산업안전보건법」 제35조제1항 및 같은 법 시행규칙 제61조제3항에 따라
자율안전확인 신고증명서를 발급합니다.

2018년 02월 23일

한국산업안전보건공단 서울지역본부장

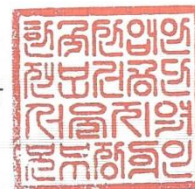



자율안전확인 신고증명서

신청인	사업장명	두산로보틱스주식회사	사업장관리번호	257-88-001280
	사업자등록번호	257-88-00128	대표자 성명	이병서
	소재지	(16648) 경기도 수원시 권선구 산업로156번길 79		
자율안전인증대상 기계·기구명		산업용로봇		
형식(규격)	M1013	용량(등급)	6 axis	
자율안전확인번호	17-AB1EQ-01514			
제조사	두산로보틱스주식회사			
소재지	(16648) 경기도 수원시 권선구 산업로156번길 79			

「산업안전보건법」 제35조제1항 및 같은 법 시행규칙 제61조제3항에 따라
자율안전확인 신고증명서를 발급합니다.

2017년 12월 05일



한국산업안전보건공단 서울지역본부장

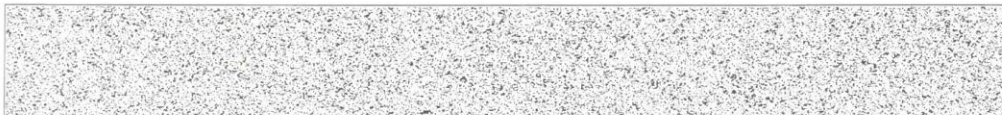



자율안전확인 신고증명서

신청인	사업장명	두산로보틱스주식회사	사업장관리번호	257-88-001280
	사업자등록번호	257-88-00128	대표자 성명	이병서
	소재지	(16648) 경기도 수원시 권선구 산업로156번길 79		
자율안전인증대상 기계·기구명		산업용로봇		
형식(규격)	M0617	용량(등급)	6 axis	
자율안전확인번호	17-AB1EQ-01515			
제조사	두산로보틱스주식회사			
소재지	(16648) 경기도 수원시 권선구 산업로156번길 79			

「산업안전보건법」 제35조제1항 및 같은 법 시행규칙 제61조제3항에 따라
자율안전확인 신고증명서를 발급합니다.

2017년 12월 05일



한국산업안전보건공단 서울지역본부장

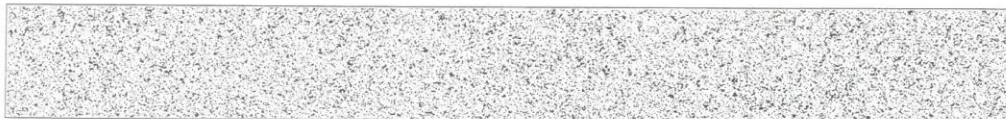



자율안전확인 신고증명서

신청인	사업장명	두산로보틱스(주)	사업장관리번호	257-88-001280
	사업자등록번호	257-88-00128	대표자 성명	곽상철
	소재지	(16648) 경기도 수원시 권선구 산업로156번길 79(고색동)		
자율안전인증대상 기계·기구명		산업용로봇		
형식(규격)	H2017	용량(등급)	6 axis	
자율안전확인번호		20-AE1EQ-02737		
제조사	두산로보틱스(주)			
소재지	(16648) 경기도 수원시 권선구 산업로156번길 79(고색동)			

「산업안전보건법」 제89조제1항 및 같은 법 시행규칙 제120조제3항에 따라
자율안전확인 신고증명서를 발급합니다.

2020년 08월 13일

한국산업안전보건공단 인천광역시본부장





자율안전확인 신고증명서

신청인	사업장명	두산로보틱스(주)	사업장관리번호	257-88-001280
	사업자등록번호	257-88-00128	대표자 성명	곽상철
	소재지	(16648) 경기도 수원시 권선구 산업로156번길 79(고색동)		
자율안전인증대상 기계·기구명		산업용로봇		
형식(규격)	H2515	용량(등급)	6 axis	
자율안전확인번호	20-AE1EQ-02738			
제조사	두산로보틱스(주)			
소재지	(16648) 경기도 수원시 권선구 산업로156번길 79(고색동)			

「산업안전보건법」 제89조제1항 및 같은 법 시행규칙 제120조제3항에 따라
자율안전확인 신고증명서를 발급합니다.

2020년 08월 13일

한국산업안전보건공단 인천광역시본부장



Annex C Stop Distance and Stop Time

C.1 Measurement Methods and Conditions

C.1.1 General Information

- Stop distance is the angle traveled from the moment a stop signal is generated to the moment all manipulator stop operation.
- Stop time is the time from the moment a stop signal is generated to the moment all manipulator stop operation.
- Stop distance and stop time data are provided for Joint 1, Joint 2 and Joint 3, which have large travel distances.
- The movement of an overlapping axis can cause a longer stop distance.
- Stop distance and stop time data are defined according to KS B ISO 10218-1:2011 Annex B.

C.1.2 Stop Category:

- Stop Category 1
The stop distance and stop time of **Joint 1 (Base) and Joint 2 (Shoulder)** are measured at 33%, 66% and 100% of the maximum speed, stretch level and load, respectively. The stop distance and stop time of **Joint 3 (elbow)** is measured at 33%, 66% and 100% of maximum speed and load. The stretch level during Joint 3 measurement is locked at maximum because of the lower arm length and completely flat wrist.
- Stop Category 0
The stop distance and stop time of Joint 1 (Base), Joint 2 (Shoulder) and Joint 3 (Elbow) are measured at maximum speed, stretch level and load. The axes of Joint 2 and Joint 3 are parallel to each other, so an impact caused by forced stop on one part may cause a slip on the other side. The angle deviation is also measured.

Note

- The measurements are the result of the worst case. Measurement may vary according to circumstances

Joint 1 measurement is performed with the rotating axis perpendicular to the ground and during horizontal movement.

Joint 2 and Joint 3 measurements are performed with the rotating axis parallel to the ground and when the robot is stopped in a downward movement vertical to the ground.

C.1.3 Measurement Poses and Conditions





	Joint 1	Joint 2	Joint 3
100% extension Stop category 0			
3% extension Stop category 1			-
66% extension Stop category 1			-
100% extension Stop category 1			

Table C.1 the pose for 33%, 66%, and 100% of extension

	Pose when the stop is initiated	Measured Angle
Joint1	<p>Stop initiating position</p>	<p>No slip, $\theta_a = \theta_{j1}$</p>
Joint2	<p>Stop initiating position</p>	<p>θ_{j2} θ_{j3} θ_a</p>
Joint3	<p>Stop initiating position</p>	<p>θ_{j3} θ_{j2} θ_a</p>

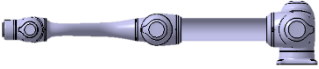
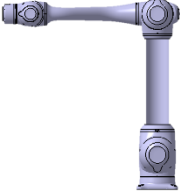
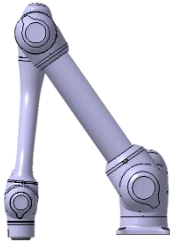
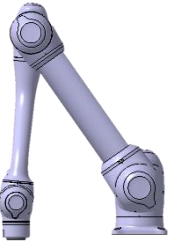
Table C.2 the pose when the stop is initiated and the measured angle (θ_a)

C.2 M1013

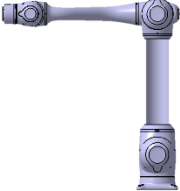
C.2.1 Stop Category 1

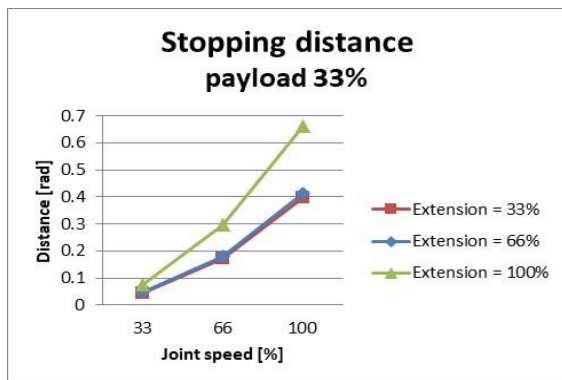

(a) Stop Distance at 33% of Max. Load (rad)

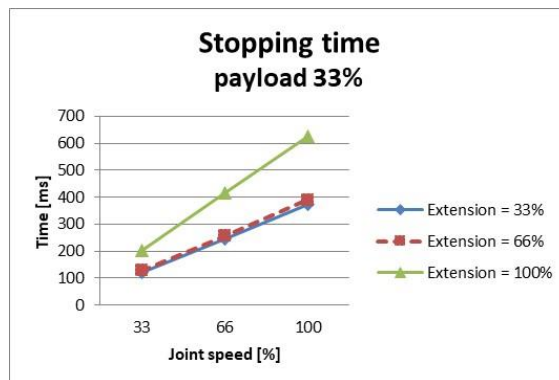

(d) Stop Time at 33% of Max. Load (ms)

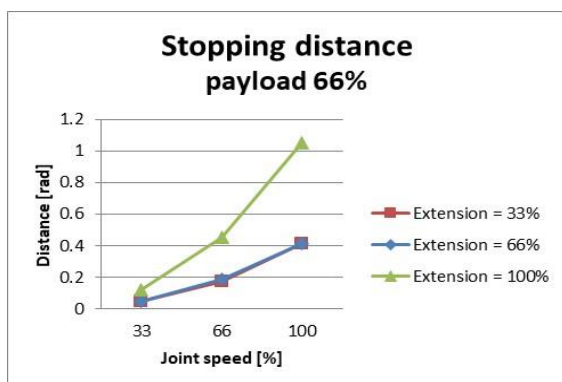

(b) Stop Distance at 66% of Max. Load (rad)

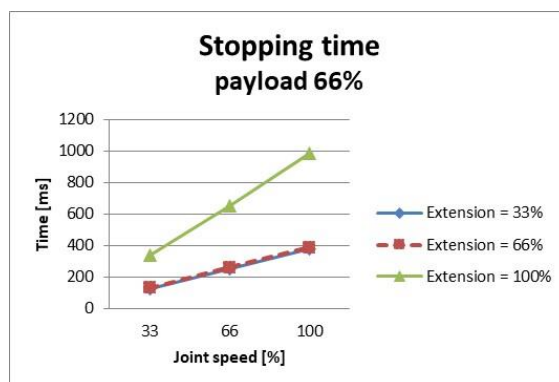

(e) Stop Time at 66% of Max. Load (ms)

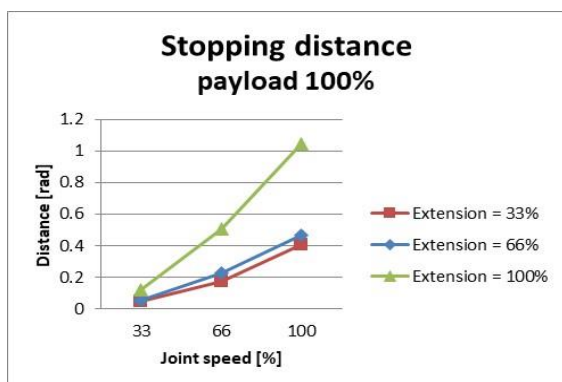

(c) Stop Distance at Max. Load (rad)

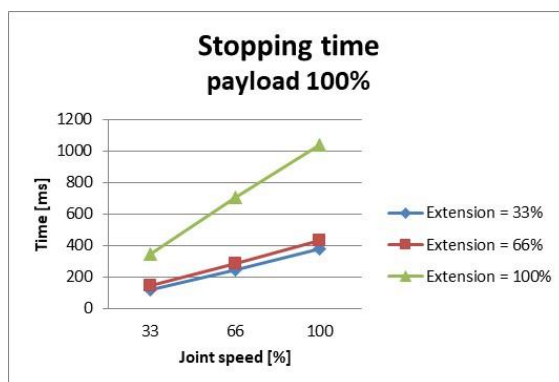

(f) Stop Time at Max. Load (ms)

Figure C.1: Stop Distance and Stop Time of Joint 1 (Base)

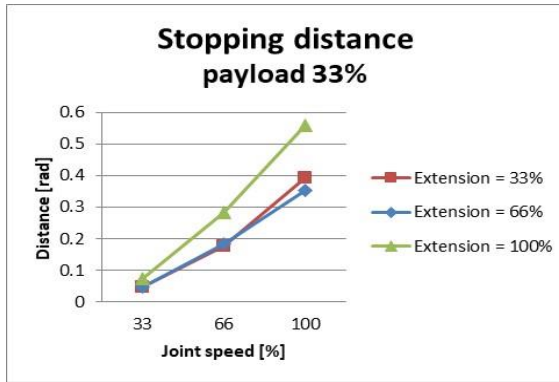

(a) Stop Distance at 33% of Max. Load (rad)

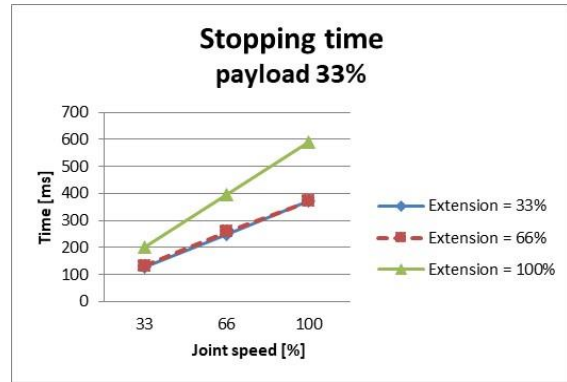

(d) Stop Time at 33% of Max. Load (ms)

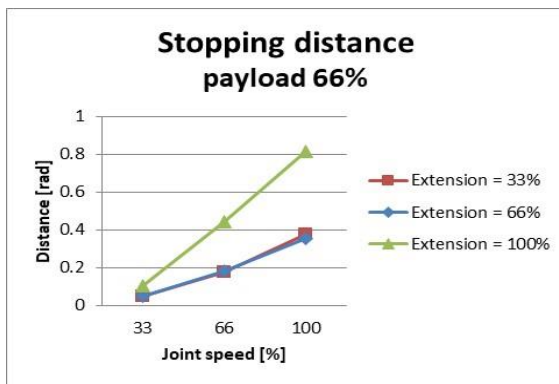

(b) Stop Distance at 66% of Max. Load (rad)

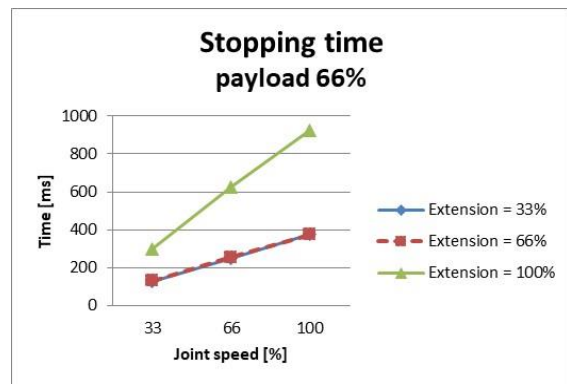

(e) Stop Time at 66% of Max. Load (ms)

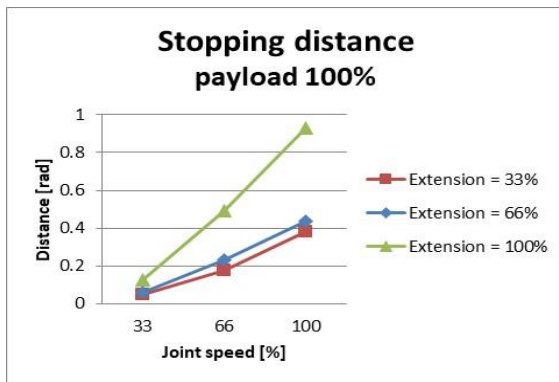

(c) Stop Distance at Max. Load (rad)

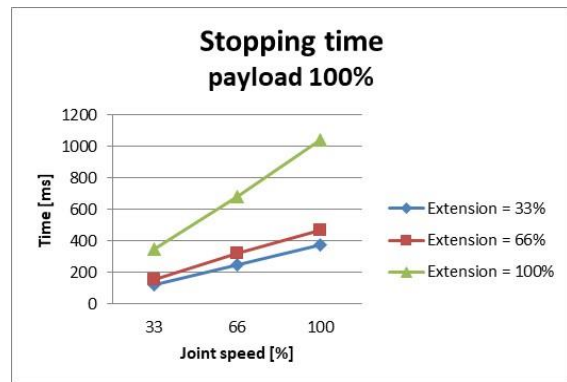

(f) Stop Time at Max. Load (ms)

Figure C.2: Stop Distance and Stop Time of Joint 2 (Shoulder)

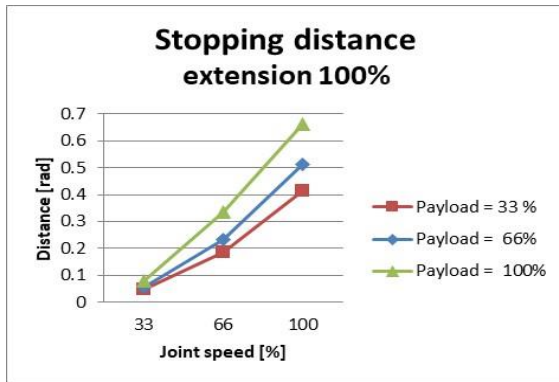

(a) Stop Distance at Max. Stretch Level (rad)

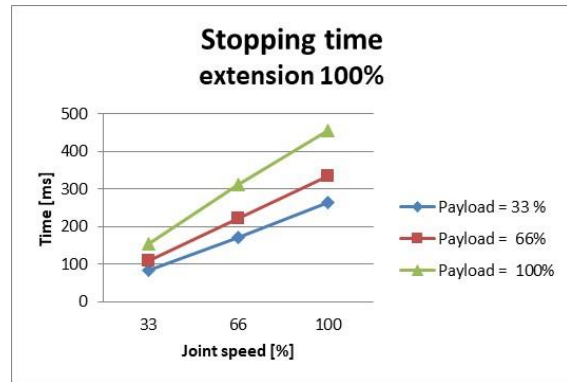

(b) Stop Time at Max. stretch Level (ms)

Figure C.3: Stop Distance and Stop Time of Joint 3 (Elbow)

C.2.2 Stop Category 0

	Joint 1	
	Extension=100%, Speed=100%, Payload=100%	
	Stopping distance (rad)	Stopping time (ms)
Joint 1	0.144	136

	Joint 2	
	Extension=100%, Speed=100%, Payload=100%	
	Stopping distance (rad)	Stopping time (ms)
Joint 2 (θ_{j2})	0.15	315
Joint 3 (θ_{j3})	0.346	
Distance (θ_{jd})	0.314	

	Joint 3	
	Extension=100%, Speed=100%, Payload=100%	
	Stopping distance (rad)	Stopping time (ms)
Joint 2 (θ_{j2})	0.161	225
Joint 3 (θ_{j3})	0.153	
Distance (θ_{jd})	0.279	

※ The joint 2 and joint 3 angles are refer to θ_{j2} , θ_{j3} , θ_d in table C.2

C.3 M0609

C.3.1 Stop Category 1

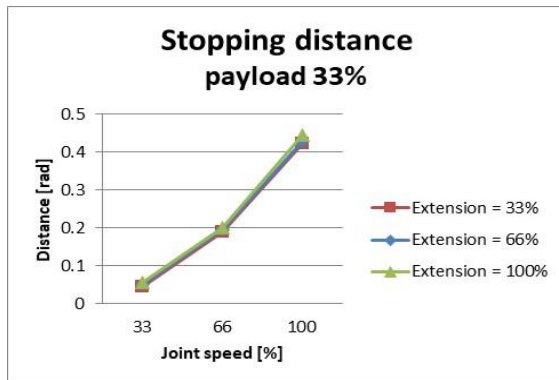

(a) Stop Distance at 33% of Max. Load (rad)

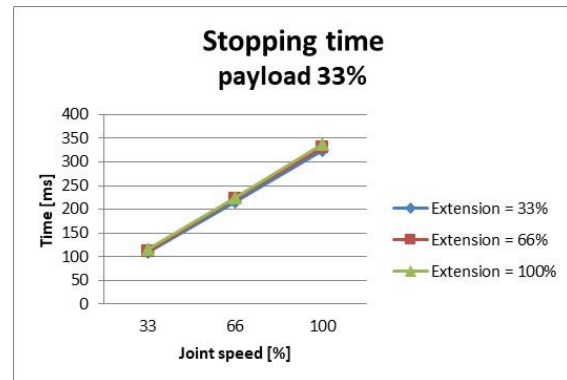

(d) Stop Time at 33% of Max. Load (ms)

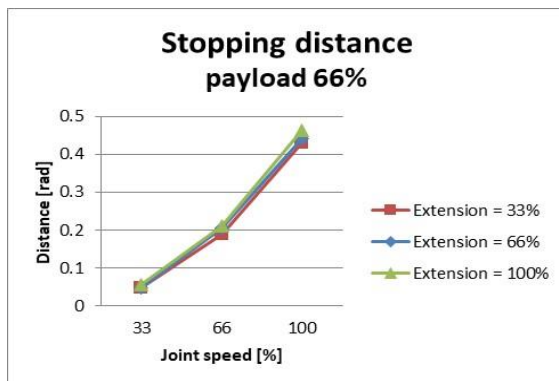

(b) Stop Distance at 66% of Max. Load (rad)

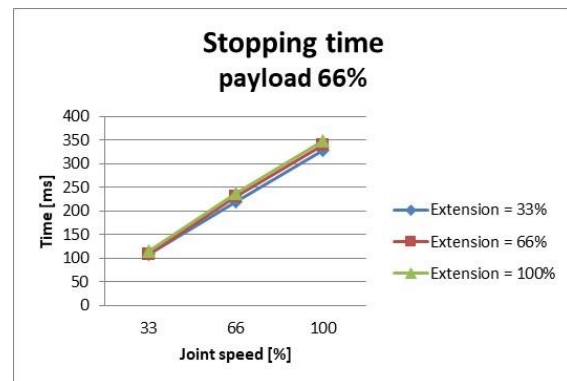

(e) Stop Time at 66% of Max. Load (ms)

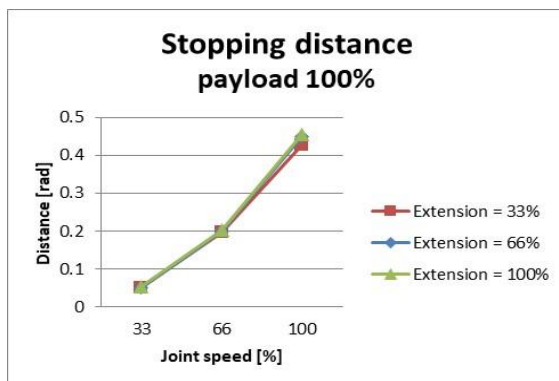

(c) Stop Distance at Max. Load (rad)

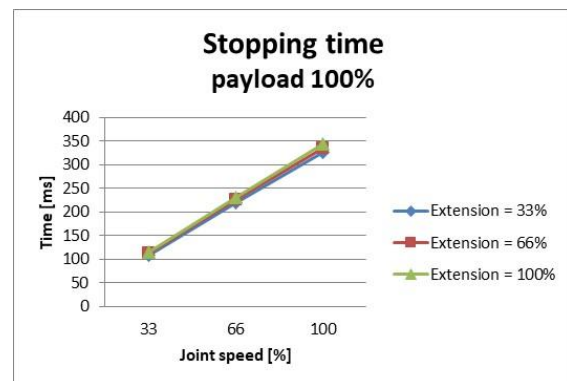

(f) Stop Time at Max. Load (ms)

Figure C.4: Stop Distance and Stop Time of Joint 1 (Base)

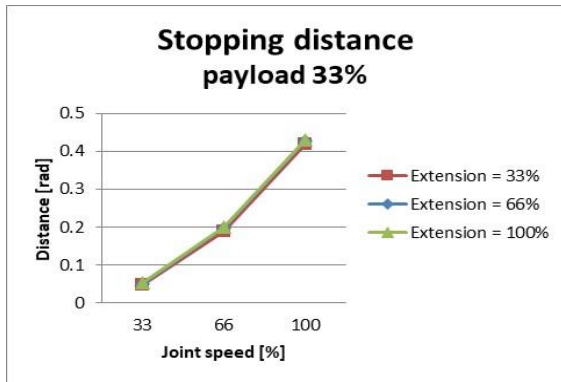

(a) Stop Distance at 33% of Max. Load (rad)

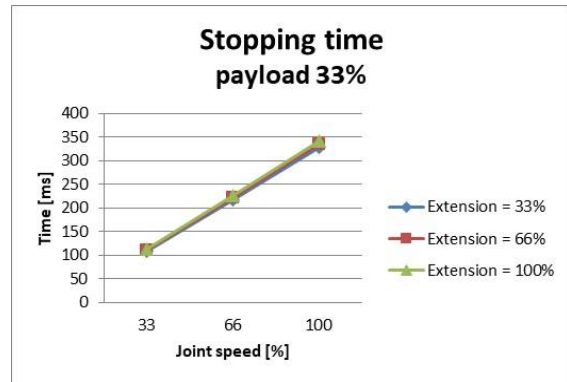

(d) Stop Time at 33% of Max. Load (ms)

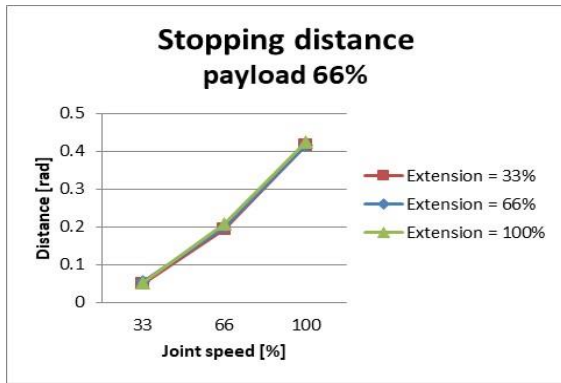

(b) Stop Distance at 66% of Max. Load (rad)

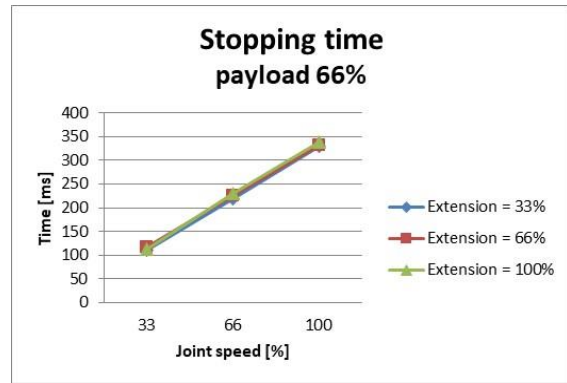

(e) Stop Time at 66% of Max. Load (ms)

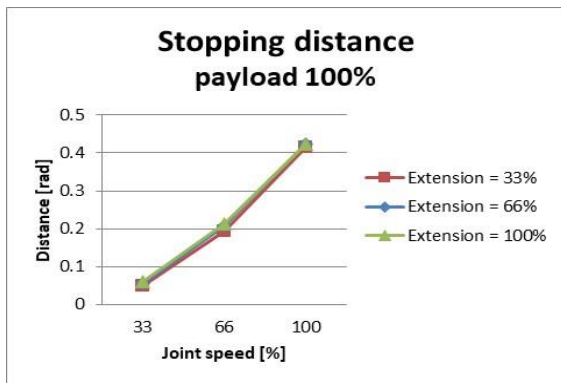

(c) Stop Distance at Max. Load (rad)

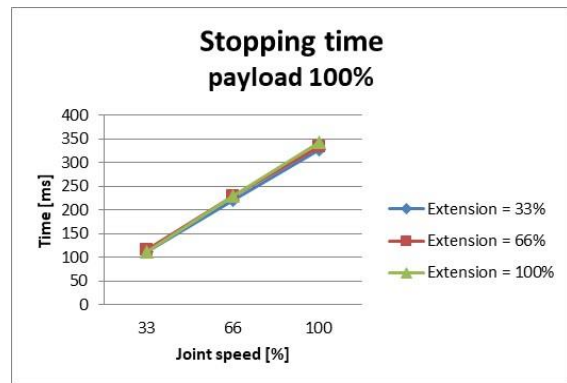

(f) Stop Time at Max. Load (ms)

Figure C.5: Stop Distance and Stop Time of Joint 2 (Shoulder)

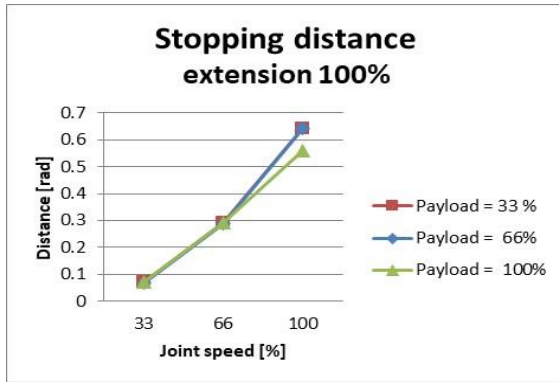

(a) Stop Distance at Max. Stretch Level (rad)

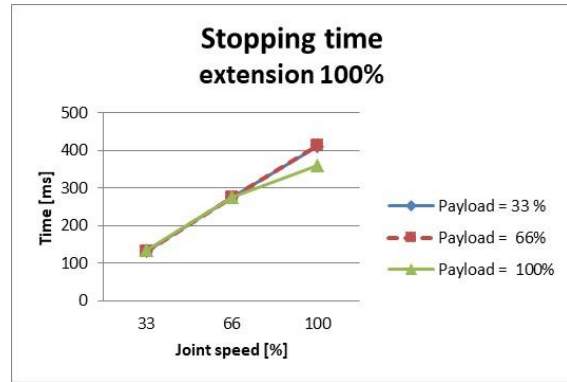

(b) Stop Time at Max. stretch Level (ms)

Figure C.6: Stop Distance and Stop Time of Joint 3 (Elbow)

C.3.2 Stop Category 0

	Joint 1	
	Extension=100%, Speed=100%, Payload=100%	
	Stopping distance(rad)	Stopping time(ms)
Joint 1	0.133	92

	Joint 2	
	Extension=100%, Speed=100%, Payload=100%	
	Stopping distance(rad)	Stopping time(ms)
Joint 2 (θ_{j2})	0.171	305
Joint 3 (θ_{j3})	0.05	
Distance (θ_{jd})	0.195	

	Joint 3	
	Extension=100%, Speed=100%, Payload=100%	
	Stopping distance(rad)	Stopping time(ms)
Joint 2 (θ_{j2})	0.034	113
Joint 3 (θ_{j3})	0.122	
Distance (θ_{jd})	0.151	

※ The joint 2 and joint 3 angles are refer to θ_{j2} , θ_{j3} , θ_d in table C.2

C.4 M0617

C.4.1 Stop Category 1

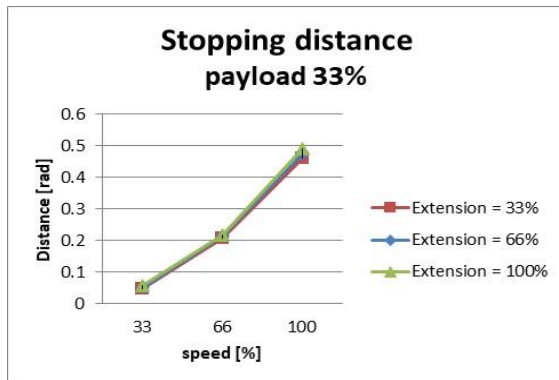

(a) Stop Distance at 33% of Max. Load (rad)

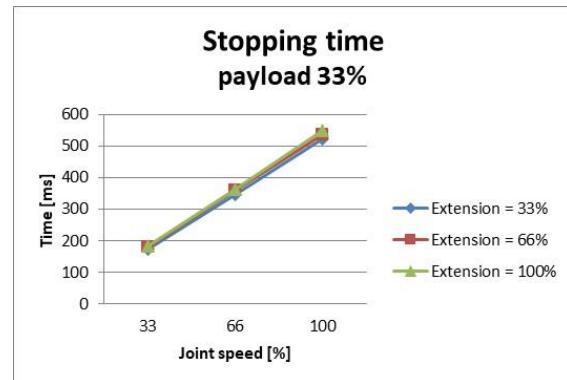

(d) Stop Time at 33% of Max. Load (ms)

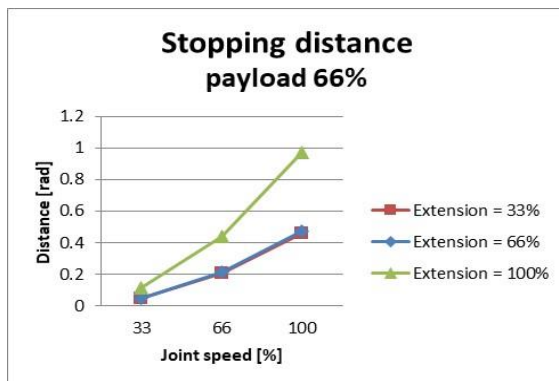

(b) Stop Distance at 66% of Max. Load (rad)

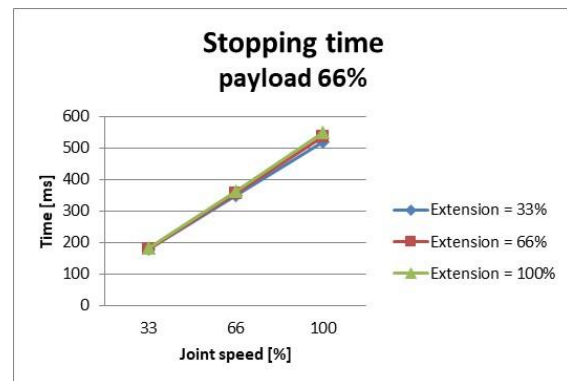

(e) Stop Time at 66% of Max. Load (ms)

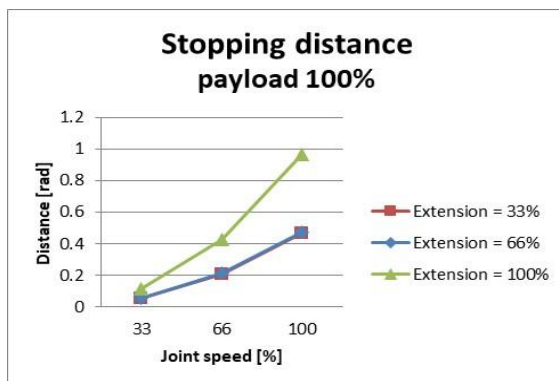

(c) Stop Distance at Max. Load (rad)

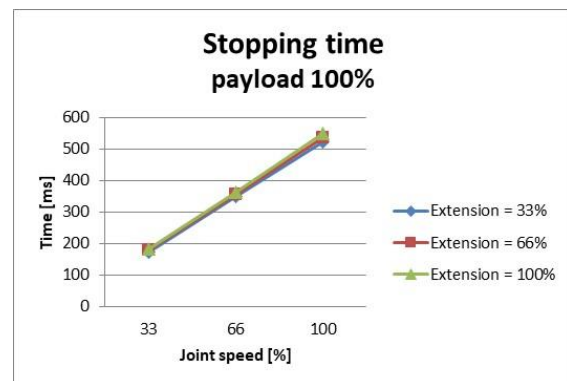

(f) Stop Time at Max. Load (ms)

Figure C.7: Stop Distance and Stop Time of Joint 1 (Base)

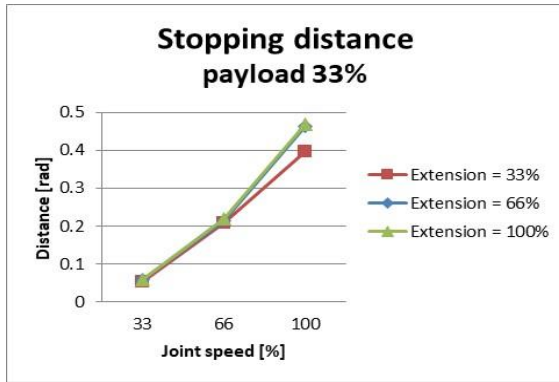

(a) Stop Distance at 33% of Max. Load (rad)

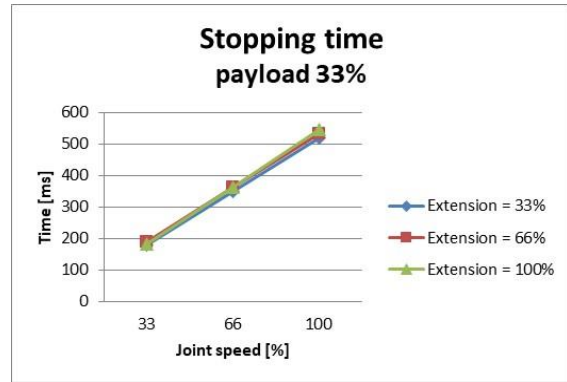

(d) Stop Time at 33% of Max. Load (ms)

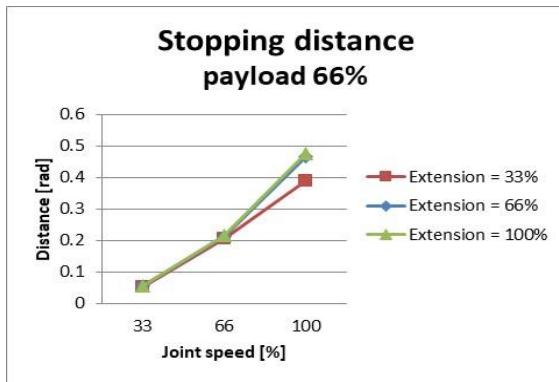

(b) Stop Distance at 66% of Max. Load (rad)

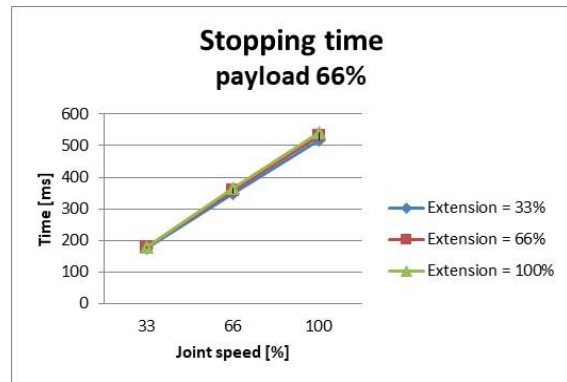

(e) Stop Time at 66% of Max. Load (ms)

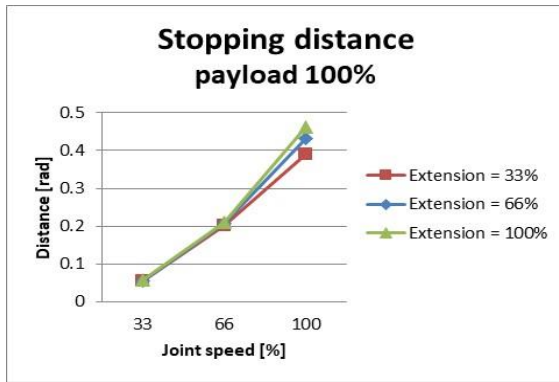

(c) Stop Distance at Max. Load (rad)

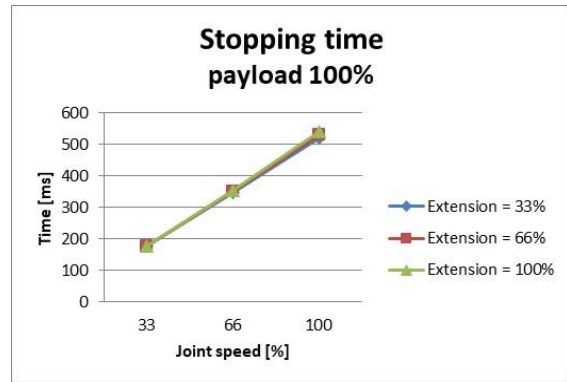

(f) Stop Time at Max. Load (ms)

Figure C.8: Stop Distance and Stop Time of Joint 2 (Shoulder)

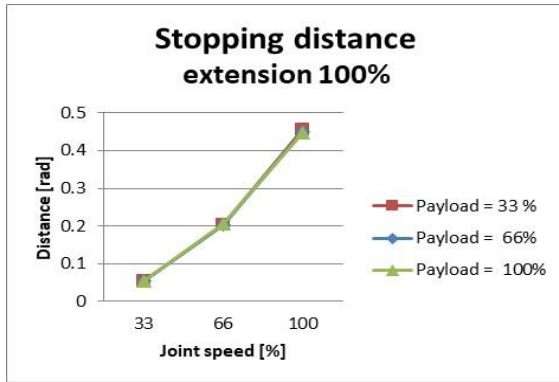

(a) Stop Distance at Max. Stretch Level (rad)

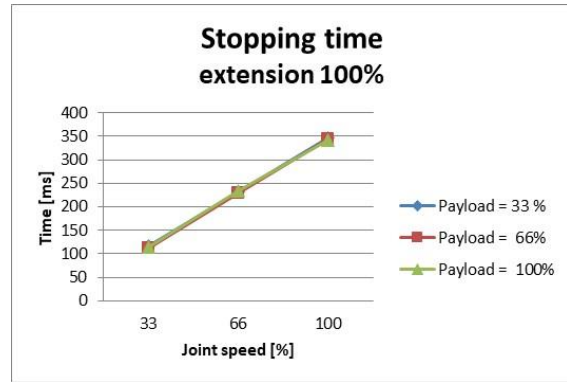

(b) Stop Time at Max. stretch Level (ms)

Figure C.9: Stop Distance and Stop Time of Joint 3 (Elbow)

C.4.2 Stop Category 0

	Joint 1	
	Extension=100%, Speed=100%, Payload=100%	
	Stopping distance(rad)	Stopping time(ms)
Joint 1	0.095	89

	Joint 2	
	Extension=100%, Speed=100%, Payload=100%	
	Stopping distance(rad)	Stopping time(ms)
Joint 2 (θ_{j2})	0.104	326
Joint 3 (θ_{j3})	0.336	
Distance (θ_{jd})	0.26	

	Joint 3	
	Extension=100%, Speed=100%, Payload=100%	
	Stopping distance(rad)	Stopping time(ms)
Joint 2 (θ_{j2})	0.079	173
Joint 3 (θ_{j3})	0.119	
Distance (θ_{jd})	0.185	

※ The joint 2 and joint 3 angles are refer to θ_{j2} , θ_{j3} , θ_d in table C.2

C.5 M1509

C.5.1 Stop Category 1

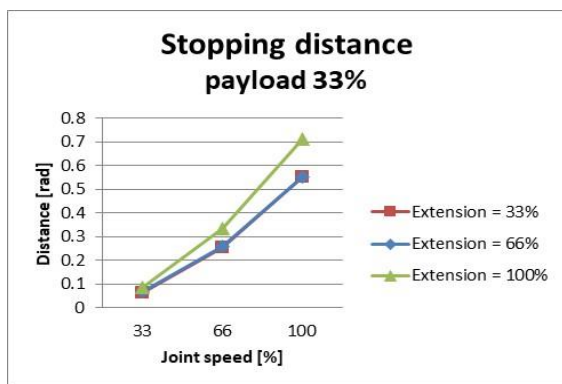

(a) Stop Distance at 33% of Max. Load (rad)

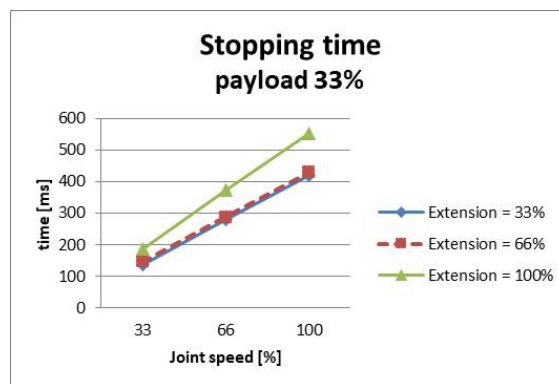

(d) Stop Time at 33% of Max. Load (ms)

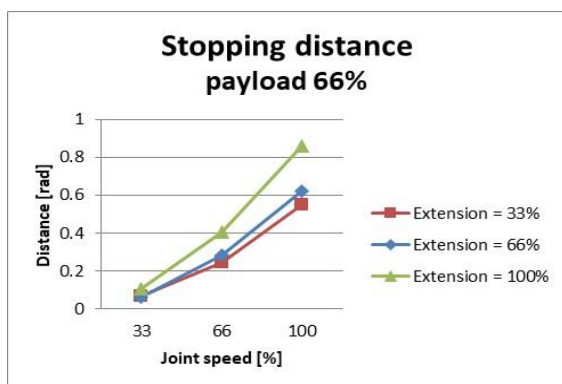

(b) Stop Distance at 66% of Max. Load (rad)

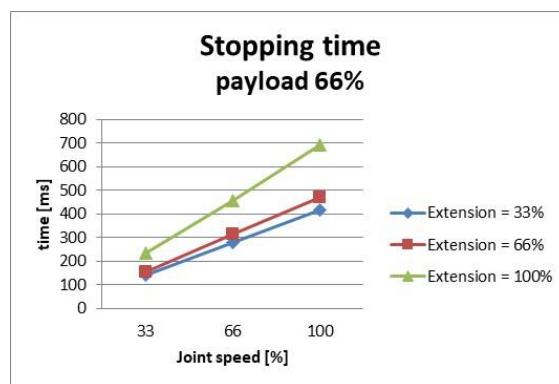

(e) Stop Time at 66% of Max. Load (ms)

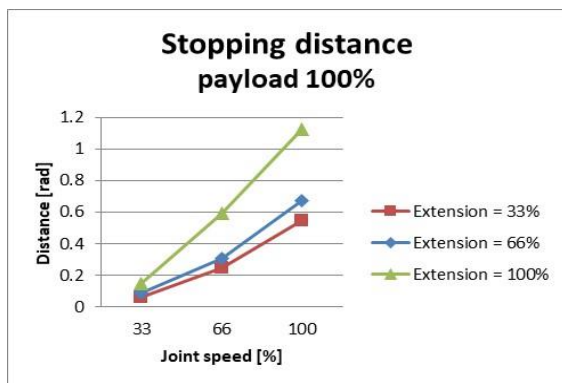

(c) Stop Distance at Max. Load (rad)

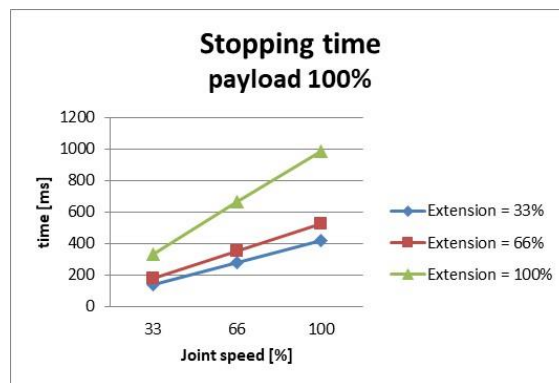

(f) Stop Time at Max. Load (ms)

Figure C.10: Stop Distance and Stop Time of Joint 1 (Base)

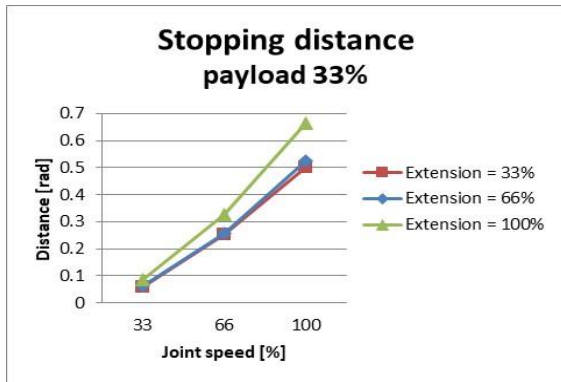

(a) Stop Distance at 33% of Max. Load (rad)

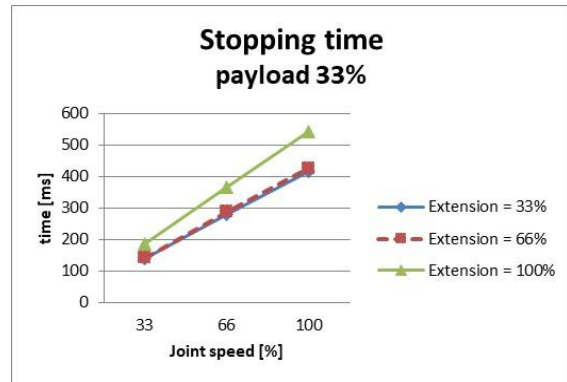

(d) Stop Time at 33% of Max. Load (ms)

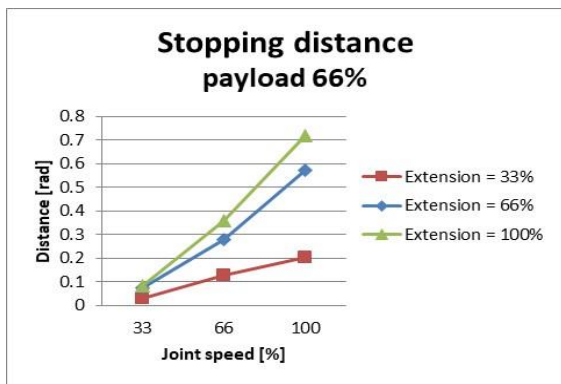

(b) Stop Distance at 66% of Max. Load (rad)

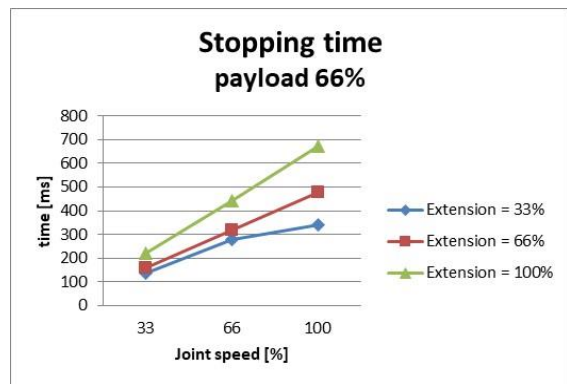

(e) Stop Time at 66% of Max. Load (ms)

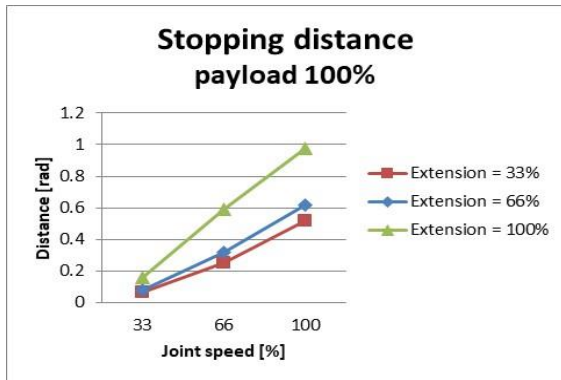

(c) Stop Distance at Max. Load (rad)

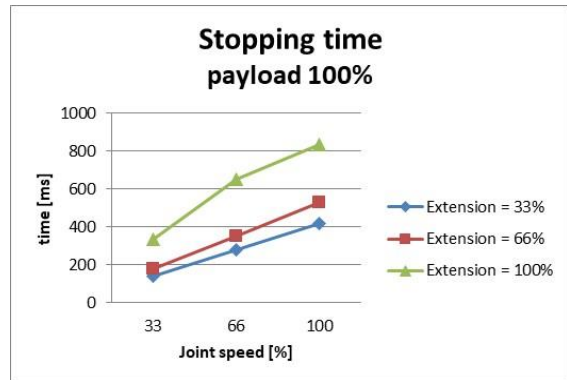

(f) Stop Time at Max. Load (ms)

Figure C.11: Stop Distance and Stop Time of Joint 2 (Shoulder)

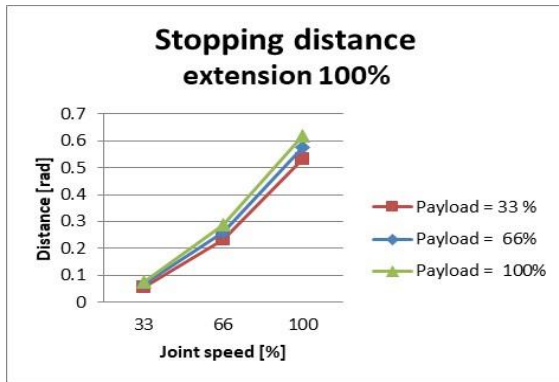

(a) Stop Distance at Max. Stretch Level (rad)

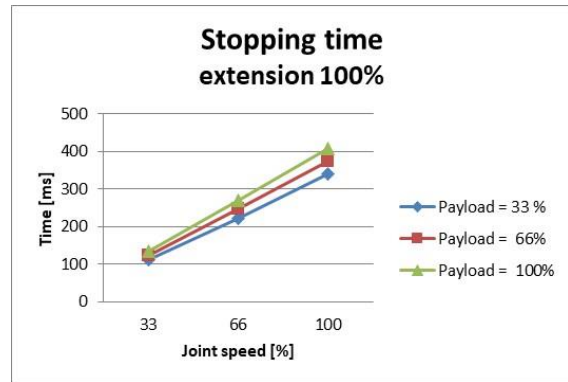

(b) Stop Time at Max. stretch Level (ms)

Figure C.12: Stop Distance and Stop Time of Joint 3 (Elbow)

C.5.2 Stop Category 0

		Joint 1	
		Extension=100%, Speed=100%, Payload=100%	
		Stopping distance(rad)	Stopping time(ms)
Joint 1		0.138	109

		Joint 2	
		Extension=100%, Speed=100%, Payload=100%	
		Stopping distance(rad)	Stopping time(ms)
Joint 2 (θ_{j2})		0.105	327
Joint 3 (θ_{j3})		0.492	
Distance (θ_{jd})		0.338	

		Joint 3	
		Extension=100%, Speed=100%, Payload=100%	
		Stopping distance(rad)	Stopping time(ms)
Joint 2 (θ_{j2})		0.155	197
Joint 3 (θ_{j3})		0.134	
Distance (θ_{jd})		0.258	

※ The joint 2 and joint 3 angles are refer to θ_{j2} , θ_{j3} , θ_d in table C.2

C.6 H2017

C.6.1 Stop Category 1

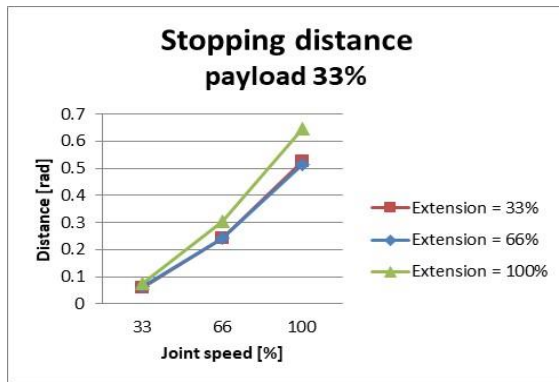

(a) Stop Distance at 33% of Max. Load (rad)

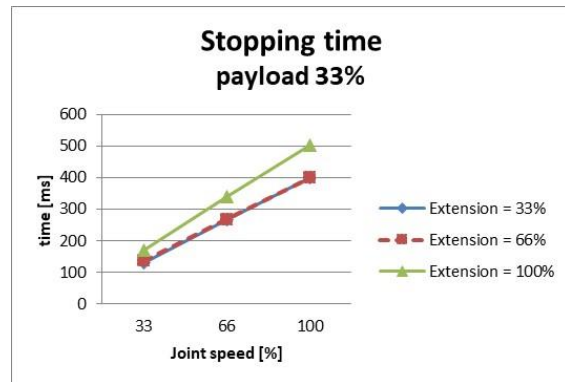

(d) Stop Time at 33% of Max. Load (ms)

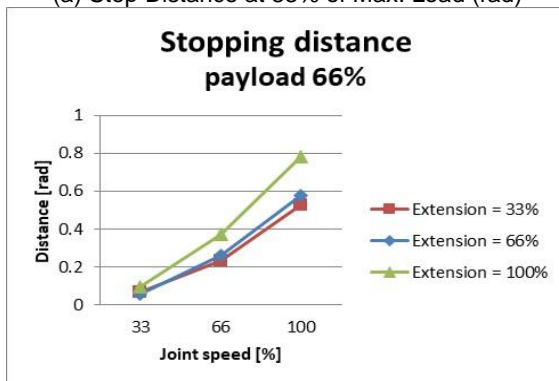

(b) Stop Distance at 66% of Max. Load (rad)

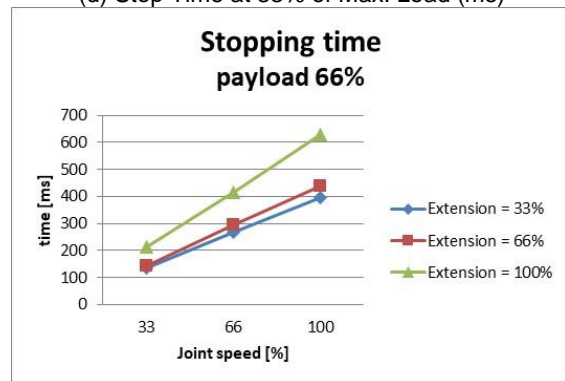

(e) Stop Time at 66% of Max. Load (ms)

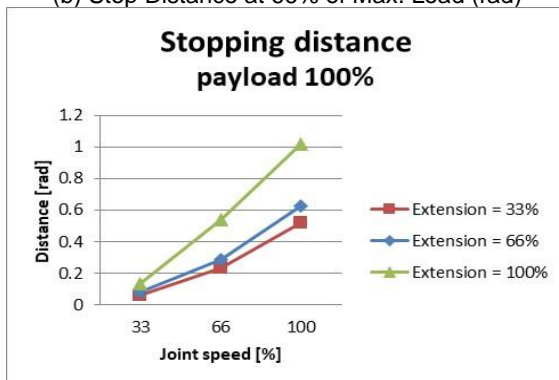

(c) Stop Distance at Max. Load (rad)

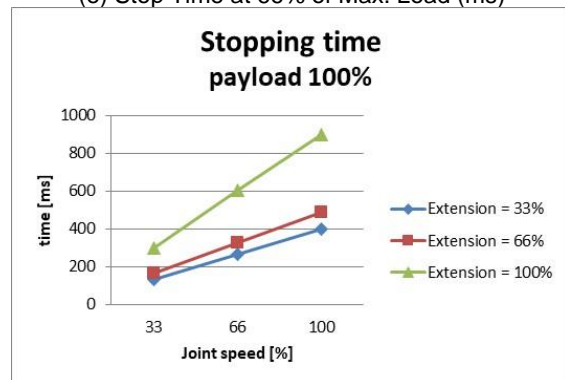

(f) Stop Time at Max. Load (ms)

Figure C.13: Stop Distance and Stop Time of Joint 1 (Base)

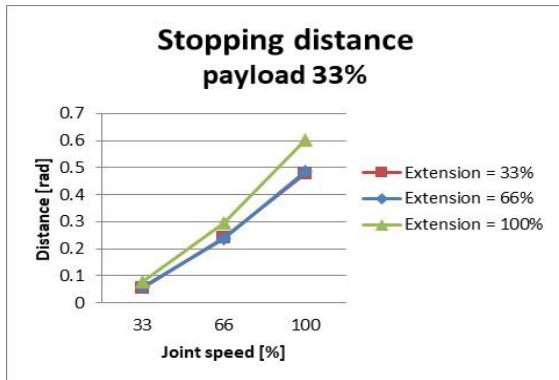

(a) Stop Distance at 33% of Max. Load (rad)

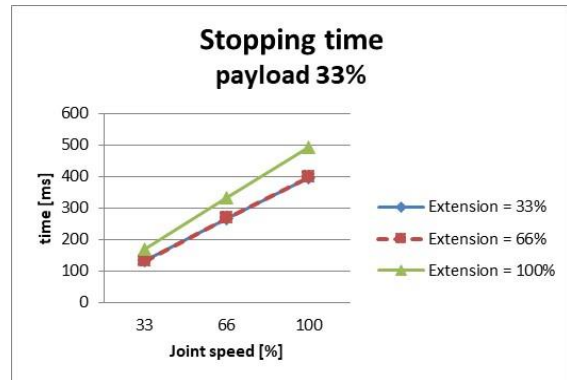

(d) Stop Time at 33% of Max. Load (ms)

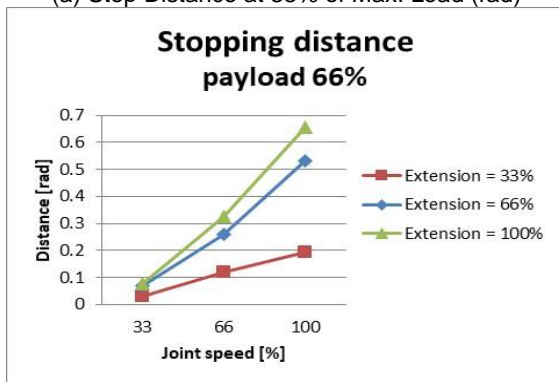

(b) Stop Distance at 66% of Max. Load (rad)

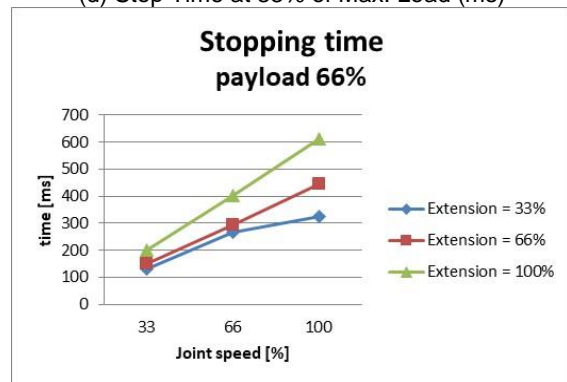

(e) Stop Time at 66% of Max. Load (ms)

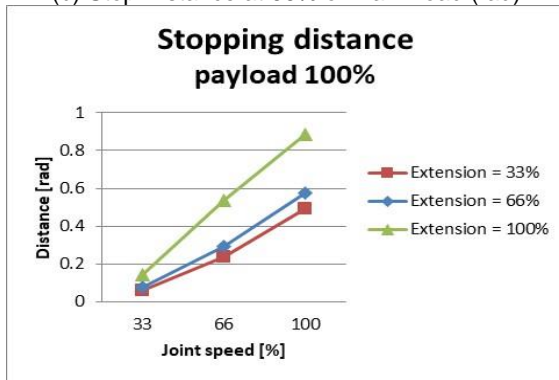

(c) Stop Distance at Max. Load (rad)

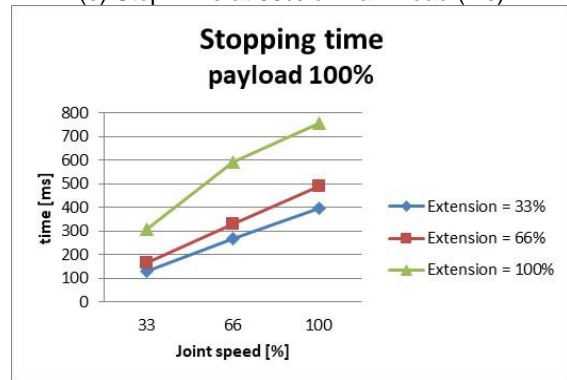

(f) Stop Time at Max. Load (ms)

Figure C.14: Stop Distance and Stop Time of Joint 2 (Shoulder)

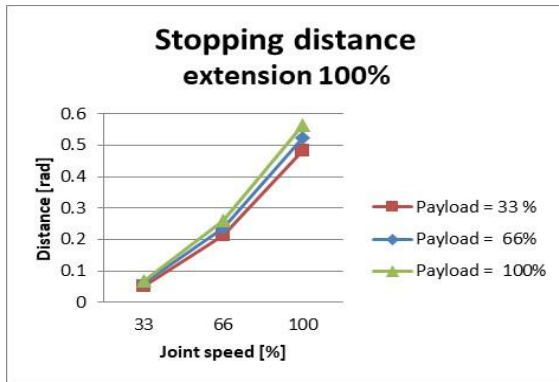

(a) Stop Distance at Max. Stretch Level (rad)

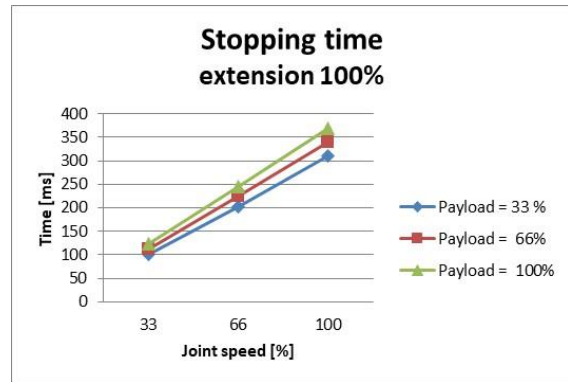

(b) Stop Time at Max. stretch Level (ms)

Figure C.15: Stop Distance and Stop Time of Joint 3 (Elbow)

C.6.2 Stop Category 0

	Joint 1	
	Extension=100%, Speed=100%, Payload=100%	
	Stopping distance (rad)	Stopping time (ms)
Axis 1	0.12483	98.867

	Joint 2	
	Extension=100%, Speed=100%, Payload=100%	
	Stopping distance (rad)	Stopping time (ms)
Axis 2	0.09471	296.568
Axis 3	0.44703	

	Joint 3	
	Extension=100%, Speed=100%, Payload=100%	
	Stopping distance (rad)	Stopping time (ms)
Axis 2	0.14045	178.785
Axis 3	0.12168	

C.7 H2515

C.7.1 Stop Category 1

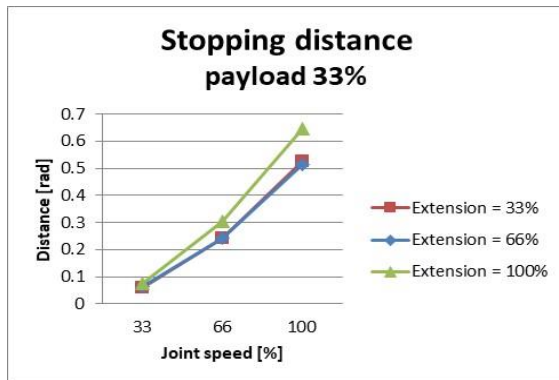

(a) Stop Distance at 33% of Max. Load (rad)

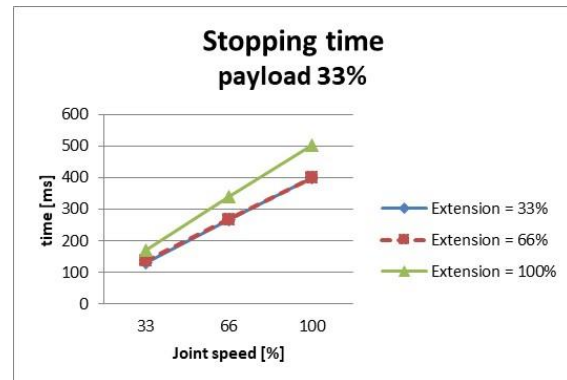

(d) Stop Time at 33% of Max. Load (ms)

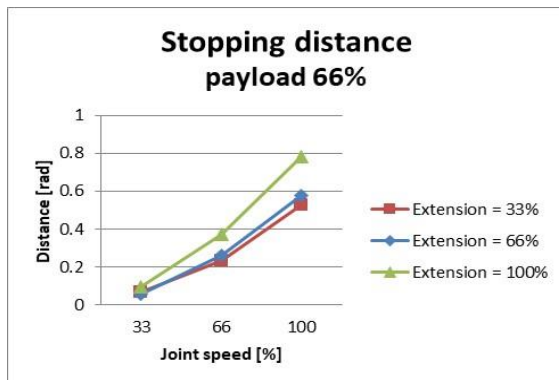

(b) Stop Distance at 66% of Max. Load (rad)

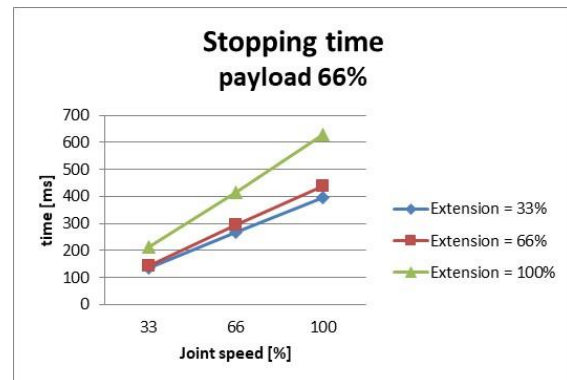

(e) Stop Time at 66% of Max. Load (ms)

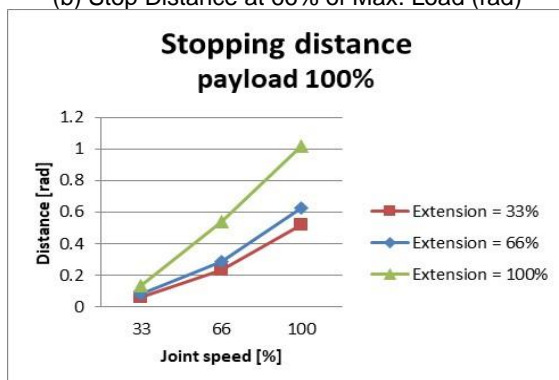

(c) Stop Distance at Max. Load (rad)

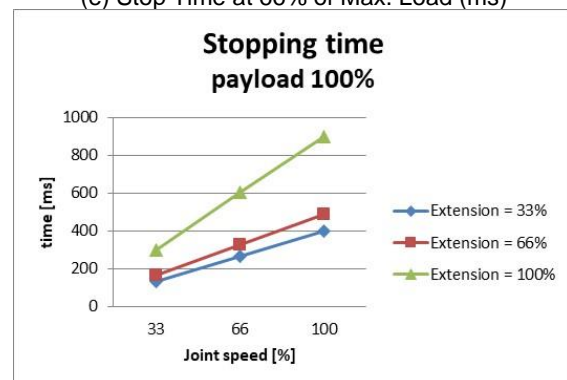

(f) Stop Time at Max. Load (ms)

Figure C.16: Stop Distance and Stop Time of Joint 1 (Base)

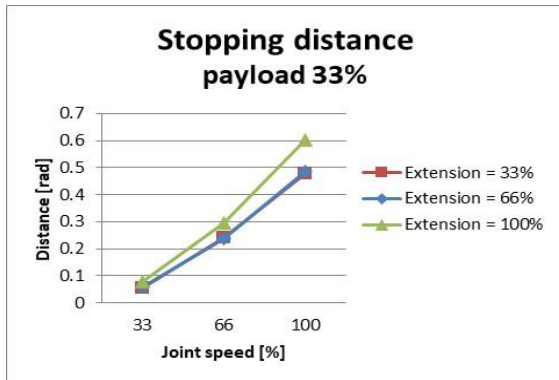

(a) Stop Distance at 33% of Max. Load (rad)

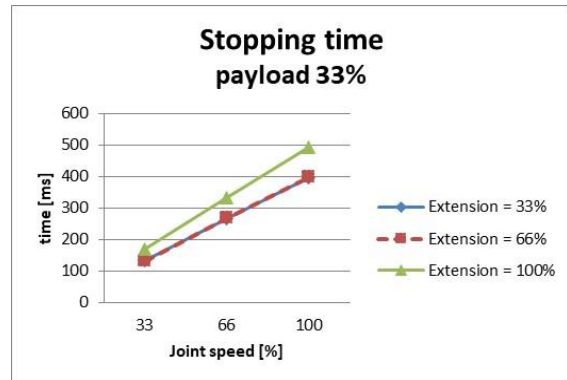

(d) Stop Time at 33% of Max. Load (ms)

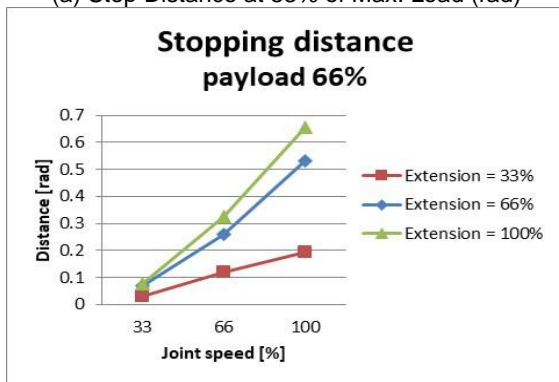

(b) Stop Distance at 66% of Max. Load (rad)

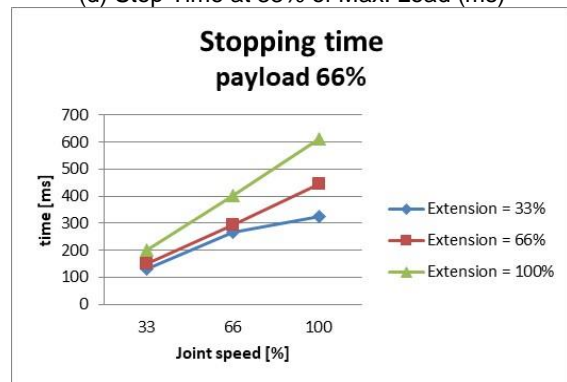

(e) Stop Time at 66% of Max. Load (ms)

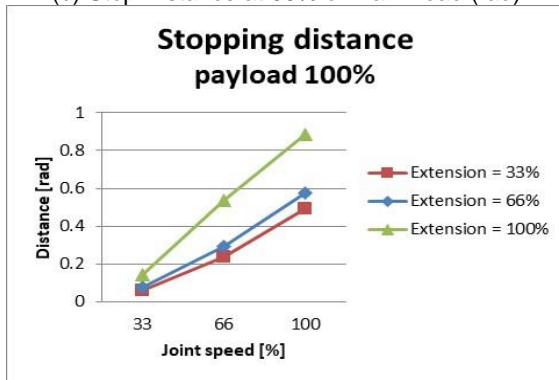

(c) Stop Distance at Max. Load (rad)

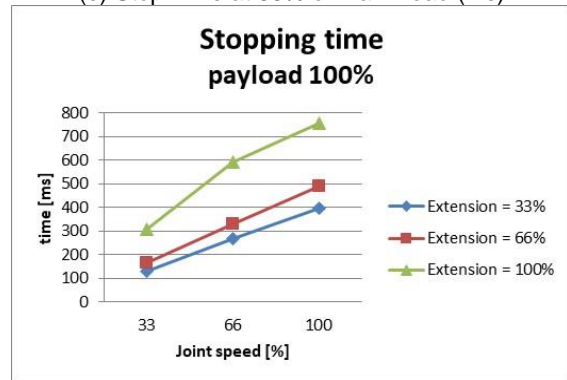

(f) Stop Time at Max. Load (ms)

Figure C.17: Stop Distance and Stop Time of Joint 2 (Shoulder)

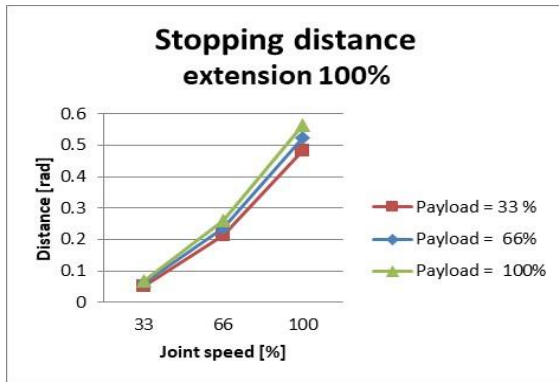

(a) Stop Distance at Max. Stretch Level (rad)

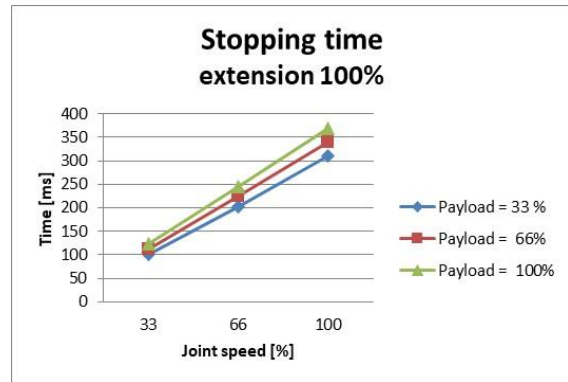

(b) Stop Time at Max. stretch Level (ms)

Figure C.18: Stop Distance and Stop Time of Joint 3 (Elbow)

C.7.2 Stop Category 0

	Joint 1	
	Extension=100%, Speed=100%, Payload=100%	
	Stopping distance (rad)	Stopping time (ms)
Axis 1	0.12483	98.867

	Joint 2	
	Extension=100%, Speed=100%, Payload=100%	
	Stopping distance (rad)	Stopping time (ms)
Axis 2	0.09471	296.568
Axis 3	0.44703	

	Joint 3	
	Extension=100%, Speed=100%, Payload=100%	
	Stopping distance (rad)	Stopping time (ms)
Axis 2	0.14045	178.785
Axis 3	0.12168	

Annex D DC Controller (CS-02)

D.1 Product Introduction

D.1.1 Names and Functions

D.1.1.1 DC Controller (CS-02)

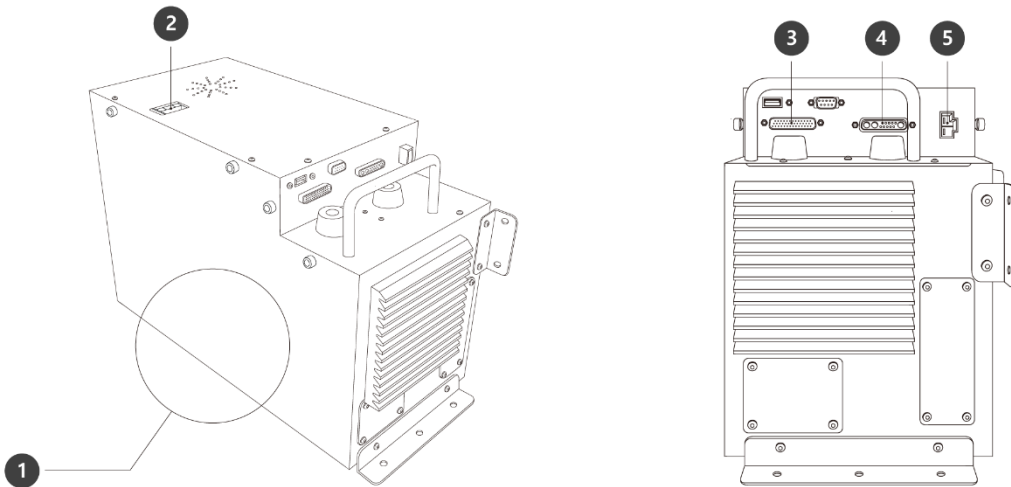

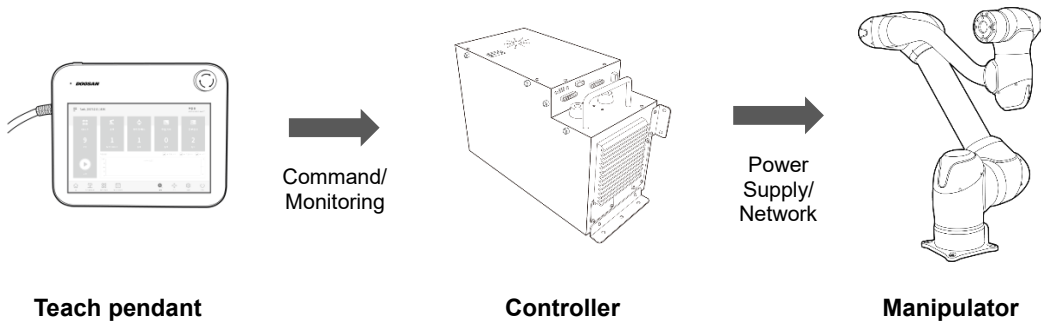

No.	Item	Description
1	I/O connection terminal (internal)	Used to connect the controller or peripherals.
2	Power switch	Used to turn ON/OFF the main power of the controller .
3	Teach pendant cable connection terminal	Used to connect the teach pendant cable to the controller .
4	robot cable connection terminal	Used to connect the robot cable to the controller .
5	Power connection terminal	Used to connect the controller power supply.

D.1.2 System Configuration



- **Teach pendant:** It is a device that manages the overall system, and it is capable of teaching the robot specific poses and setting manipulator and controller related settings.
- **Controller:** It controls the robot's movement according to the pose or movement set by the teach pendant. It features various I/O ports that allow the connection and use of various equipment and devices.
- **Manipulator:** It is an industrial collaborative robot that can perform transport or assembly tasks with various tools.

D.1.3 Nameplate and Label

	
Doosan Robotics	
73, Saneop-ro 155beon-gil, Gwangju-si, Gyeonggi-do, 16648, Republic of Korea Tel. : 82-31-8014-5200 Fax. : 82-31-8014-5691	
Designation : Robot Controller	Rated Current : 30 A
Model No. : CS-02	Rated Frequency : N/A
Drawing No. : HPT-CS02-CTFC07	S.C.C.R : N/A
Serial No. : CS-02-00-00-000	Weight : 12kg
Rated Voltage : 22-60Vdc	
	

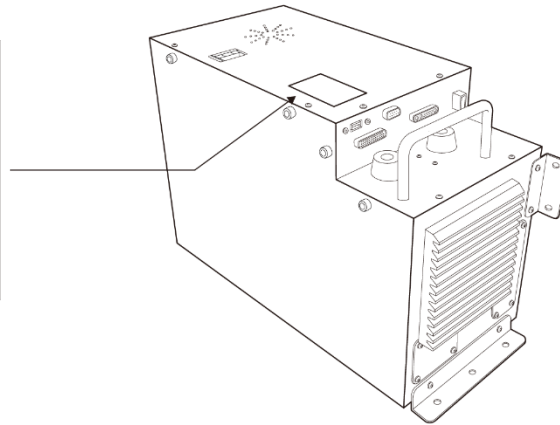

D.2 Installation

D.2.1 Cautions during Installation

 **Caution**

- Secure sufficient space before installing the controller. If not enough space is secured, the controller may be damaged or the manipulator or teach pendant cable may have a shortage.
- Check the input power supply when connecting power to the product. If the connected input power supply is different from the rated power input (22-60VDC), the product may not operate properly or the controller may be damaged.

D.2.2 Installation Environment

When installing the controller, consider the following.

- Secure sufficient space before installing the controller.
- The controller must be fixed.
- Make sure no component is not fixed in the mobile vehicle.

D.2.3 Hardware Installation

Install the robot, controller and teach pendant, the key components of the system, and supply power to them before operating the manipulator. Installation of each component is as follows:

D.2.3.1 Securing the Controller

After placing the controller, use M5 bolts in six 6 mm holes in the fixation plate to secure the controller. .
(if the control is placed horizontally, use five M5 bolts)

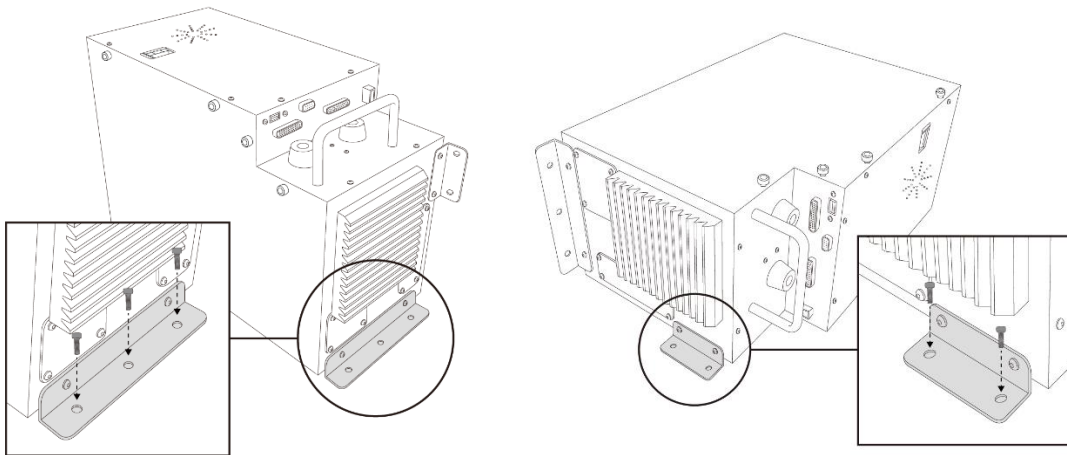

Caution

- Tighten the bolts all the way to prevent loosening.

D.2.3.2 Connecting the Manipulator and Controller

Connect the manipulator cable to the corresponding controller connector and place a securing ring on it to prevent the cable from becoming loose. Push the manipulator cable's opposite end into the corresponding controller connector until a click is heard to prevent the cable from becoming loose.

- 1 Connect the manipulator cable to the controller, place a securing ring

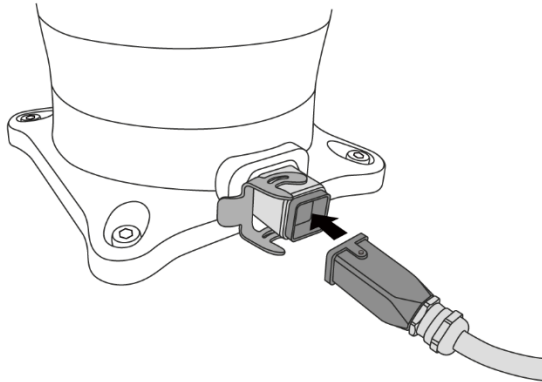

- 2 Connect the manipulator cable's opposite end to the controller connector

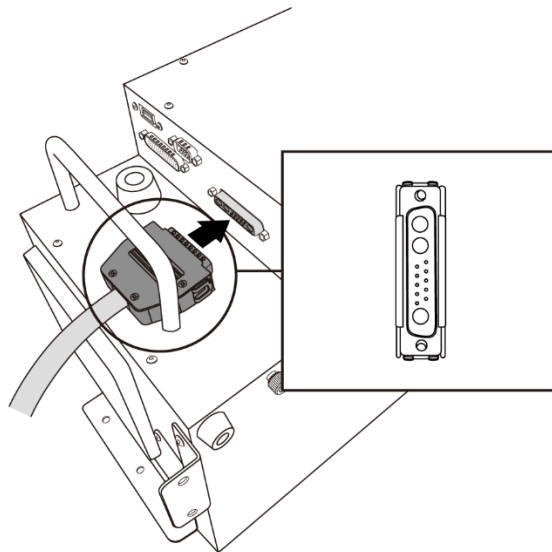



Caution

- Do not disconnect the robot cable while the robot is turned on. This can cause damage to the robot.
- Do not modify or extend the robot cable.
- When installing the controller in the mobile vehicle, secure at least 50 mm of space on each side of the controller to enable ventilation.
- Make sure that connectors are properly connected before turning on the controller.



Note

- When configuring the system, it is recommended that a noise reducer be installed to prevent noise effects and malfunction of the system.
- If the controller is influenced by noise generated by electromagnetic waves, it is necessary to install a ferrite core to ensure normal operation. The installation location is as follows:

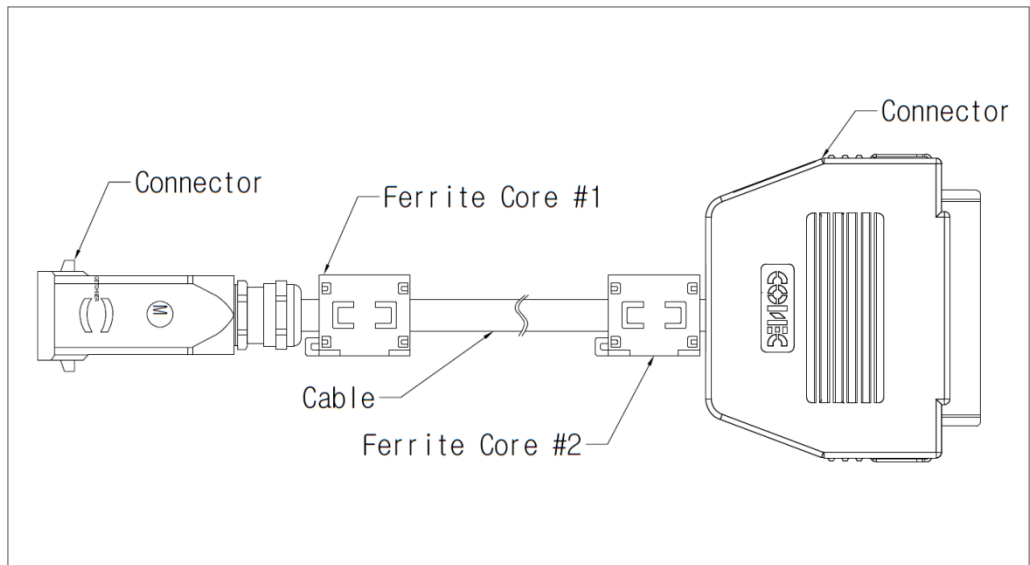

D.2.3.3 Connecting the Controller and Teach Pendant

Push the teach pendant cable into the corresponding controller connector until a click is heard to prevent the cable from becoming loose.

1 Connect the teach pendant cable to the controller connector

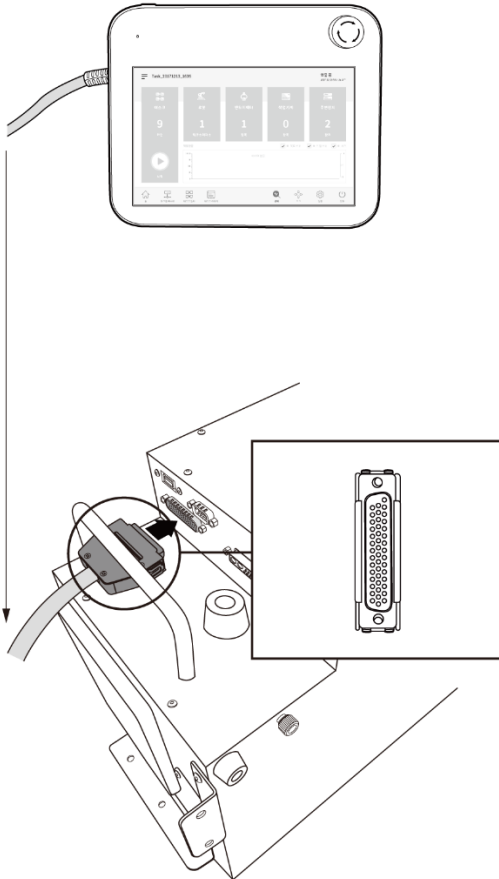

Caution

- Make sure that the pins of the cable end are not damaged or bent before connecting the cable.
- If the teach pendant is used by hanging on the mobile vehicle or on the controller, be careful not to trip on the connecting cables.
- Be careful not to allow the controller, teach pendant and cable come in contact with water.
- Do not install the controller and teach pendant in a dusty or wet environment.
- The controller and teach pendant must not be exposed to a dusty environment. Be especially careful in environments with conductive dust.

 **Note**

- When configuring the system, it is recommended that a noise reducer be installed to prevent noise effects and malfunction of the system.
- If the teach pendant is influenced by noise generated by electromagnetic waves, it is necessary to install a ferrite core to ensure normal operation. The installation location is as follows:

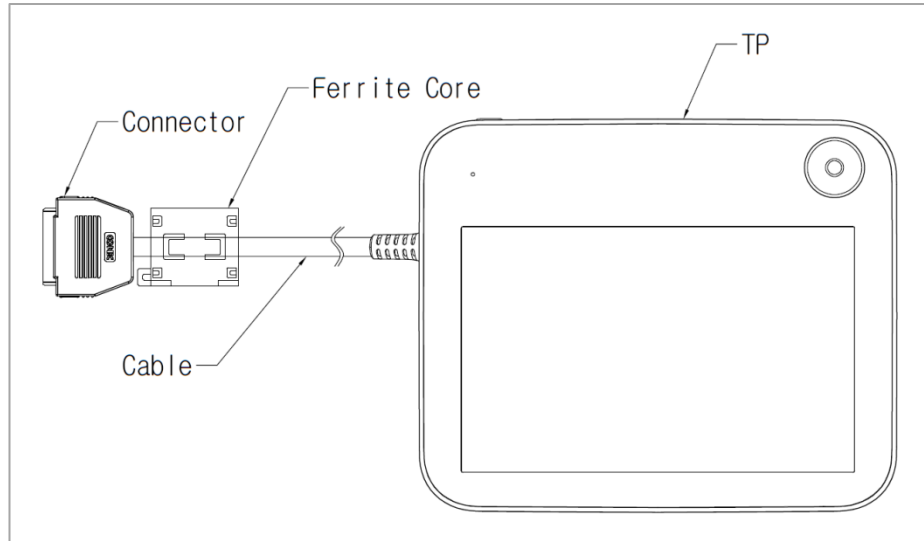

D.2.3.4 Routing of Manipulator Cable and Teach Pendant Cable

Ensure that the manipulator and teach pendant cable curvature radius is greater than the minimum curvature radius (120 mm).

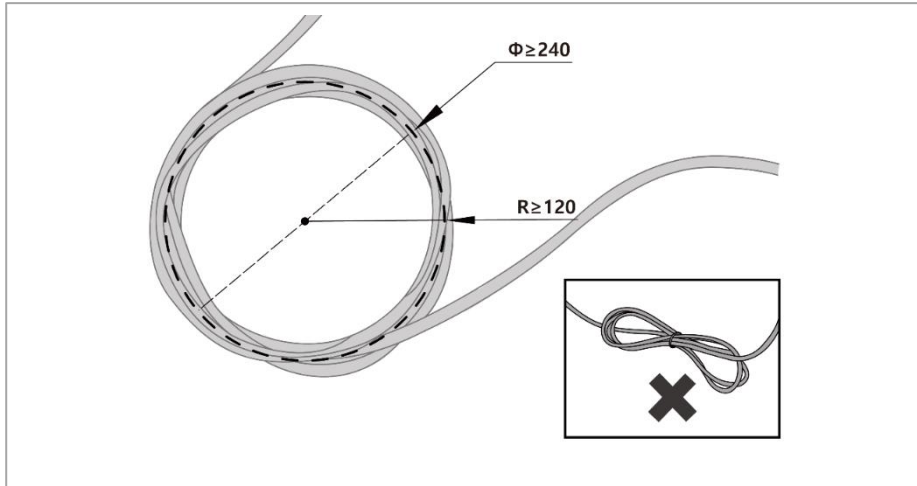

Caution

- Ensure that the curvature radius between the teach pendant cable and teach pendant connector is greater than the minimum curvature radius (120 mm).
- If the curvature radius is smaller than the minimum curvature radius (120 mm), cable disconnection or product damage may occur.
- In environments where electromagnetic noise can occur, proper cable installation must be taken to prevent malfunctions.

D.2.3.5 Supplying Power to the Controller

Push the power cable into the corresponding controller connector until a click is heard to prevent the cable from becoming loose.

- 1 Connect the supplying power cable to the controller connector

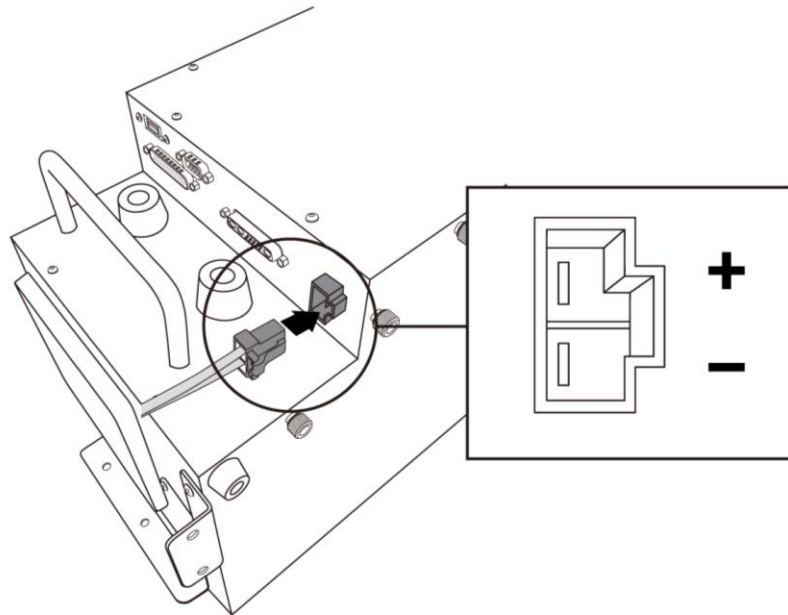

Warning

- After connecting the power cable, make sure that the robot has established a proper ground (electronic ground connection). Establish a common ground for all equipment in the system with an unused bolt related to the ground symbol inside the controller. The ground conductor must satisfy the maximum current rating of the system.
- Protect the input power of the controller using devices such as a circuit breaker.
- Do not modify or extend the robot cable. It can cause fire or controller breakdown.
- Make sure that all cables are properly connected before supplying power to the controller. Always use the original cable included in the product package.
- Be careful not to connect the polarity of the input voltage incorrectly.

 **Note**

- When configuring the system, it is recommended to install a power switch that can turn off power to all devices in the system at once.
- If a controller for the AGV is used, the robot's movement may be limited according to the load and motion.
- If the input voltage is less than 48V, the robot's movement may be limited according to the load and motion.
- The power supply must satisfy minimum requirements such as ground and circuit breakers. The electrical specifications are as follows:

Parameter	Specification
Input Voltage	22 – 60 VDC
Rated Input Current	30 A

D.3 Interface

D.3.1 Connecting Controller I/O

External devices can be connected to the controller through the controller I/O terminal after removing the I/O connection plate.

D.3.2 Network Connection

External Internet network, TCP/IP equipment, Modbus equipment and SVM can be connected to the network router in the controller after removing the network connection plate.

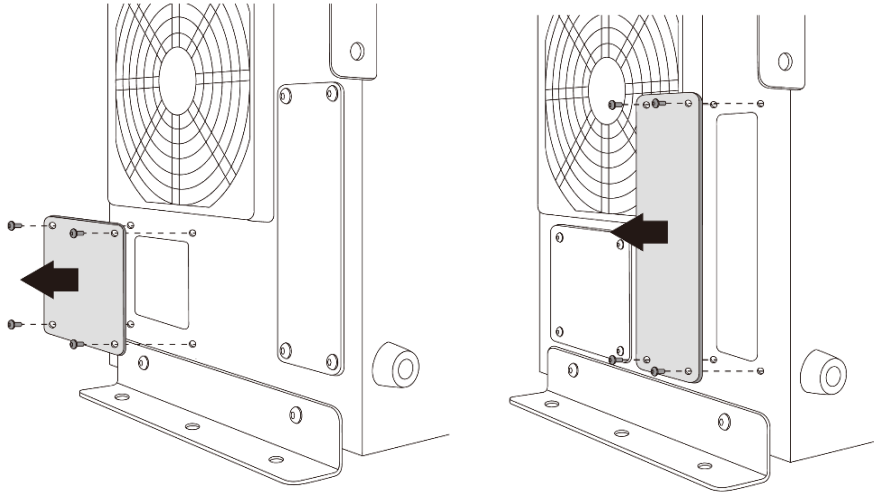

Annex E IP Steel Controller (CS-01P)

E.1 Product Introduction

E.1.1 Names and Functions

E.1.1.1 IP Steel Controller (CS-01P)

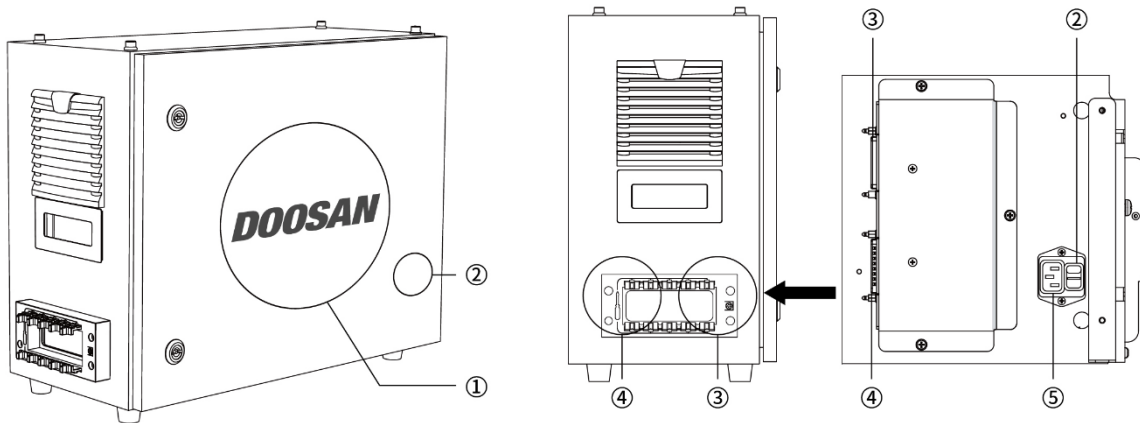

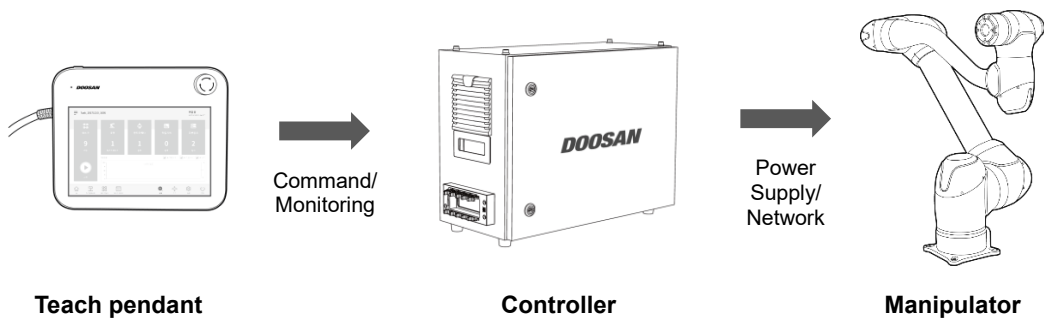

No.	Item	Description
1	I/O connection terminal (internal)	Used to connect the controller or peripherals.
2	Power switch	Used to turn ON/OFF the main power of the controller.
3	Teach pendant cable connection terminal	Used to connect the teach pendant cable to the controller.
4	robot cable connection terminal	Used to connect the robot cable to the controller.
5	Power connection terminal	Used to connect the controller power supply.

E.1.2 System Configuration



- **Teach pendant:** It is a device that manages the overall system, and it is capable of teaching the robot specific poses and setting robot and controller related settings.
- **Controller:** It controls the robot's movement according to the pose or movement set by the teach pendant. It features various I/O ports that allow the connection and use of various equipment and devices.
- **Manipulator:** It is an industrial collaborative robot that can perform transport or assembly tasks with various tools.

E.1.3 Nameplate and Label

	
Doosan Robotics	
79, Saneop-ro 156beon-gil, Gwonseon-gu, Suwon-si, Gyeonggi-do, 16648, Republic of Korea Tel : 82-31-8014-5500 Fax : 82-31-8014-5691	
Designation : Robot Controller	Rated Voltage : 100-240 VAC
Model No. : CS-01P	Rated Current : 10 A
Drawing No. : HTP-CS01P-CTFC07	Rated Frequency : 50/60 Hz
Serial No. : CS-01P-00-00-000	S.C.C.R. : 10 kA
Mfg. Year & Month : yyyy-mm	Weight : 17 kg
	

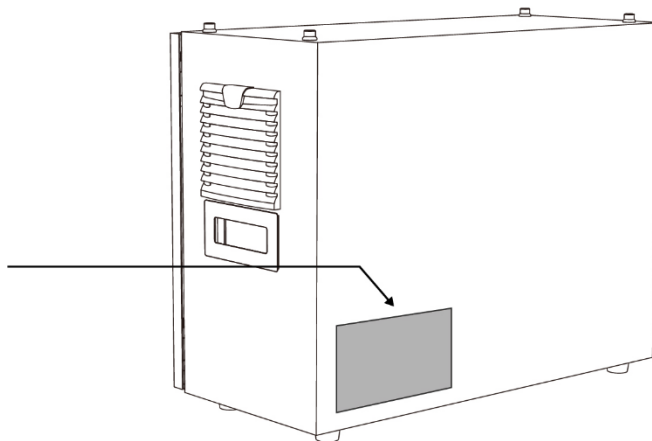

E.2 Installation

E.2.1 Cautions during Installation

 **Caution**

- Secure sufficient space for installation before installing the controller. If not enough space is secured, the controller may be damaged or the robot or teach pendant cable may have a shortage.
- Check the input power supply when connecting power to the product. If the connected input power supply is different from the rated power input (100-240VAC 50/60Hz), the product may not operate properly or the controller may be damaged.

E.2.2 Installation Environment

When installing the controller, consider the following.

- Secure sufficient space for installation before installing the controller.
- The controller must be fixed.

E.2.3 Hardware Installation

Install the robot, controller and teach pendant, the key components of the system, and supply power to them before operating the robot. Installation of each component is as follows:

E.2.3.1 Connecting the Manipulator and Controller

Connect the manipulator cable to the corresponding controller connector and place a securing ring on it to prevent the cable from becoming loose. Push the manipulator cable's opposite end into the corresponding controller connector until a click is heard to prevent the cable from becoming loose.

- 1 Connect the manipulator cable to the controller, place a securing ring

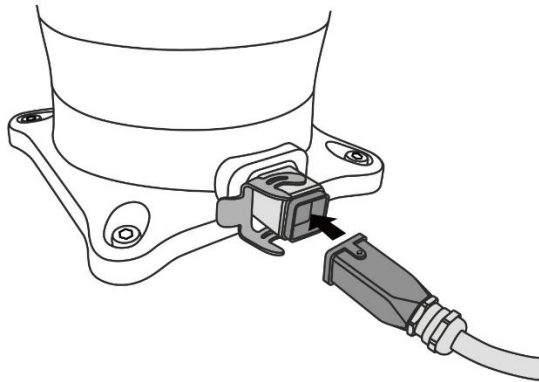

- 2 Connect the manipulator cable's opposite end to the controller connector

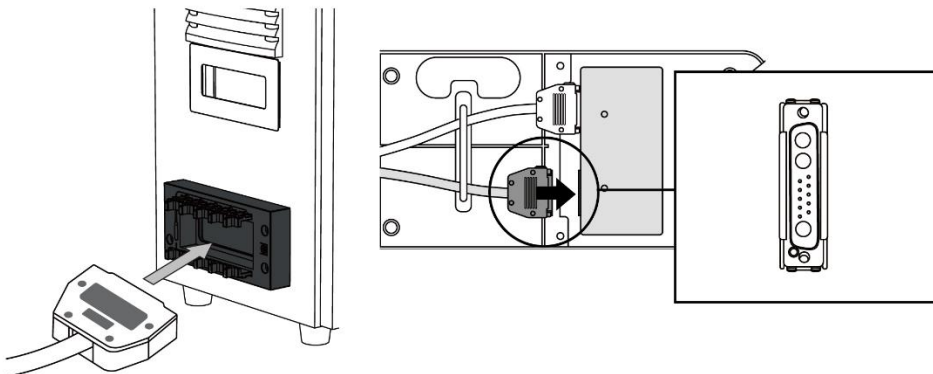



Caution

- Do not disconnect the robot cable while the robot is turned on. This can cause damage to the robot.
- Do not modify or extend the manipulator cable.
- When installing the controller, secure at least 50 mm of space on each side of the controller to enable ventilation.
- Make sure that connectors are properly connected before turning on the controller.



Note

- When configuring the system, it is recommended that a noise reducer be installed to prevent noise effects and malfunction of the system.
- If the controller is influenced by noise generated by electromagnetic waves, it is necessary to install a ferrite core to ensure normal operation. The installation location is as follows:

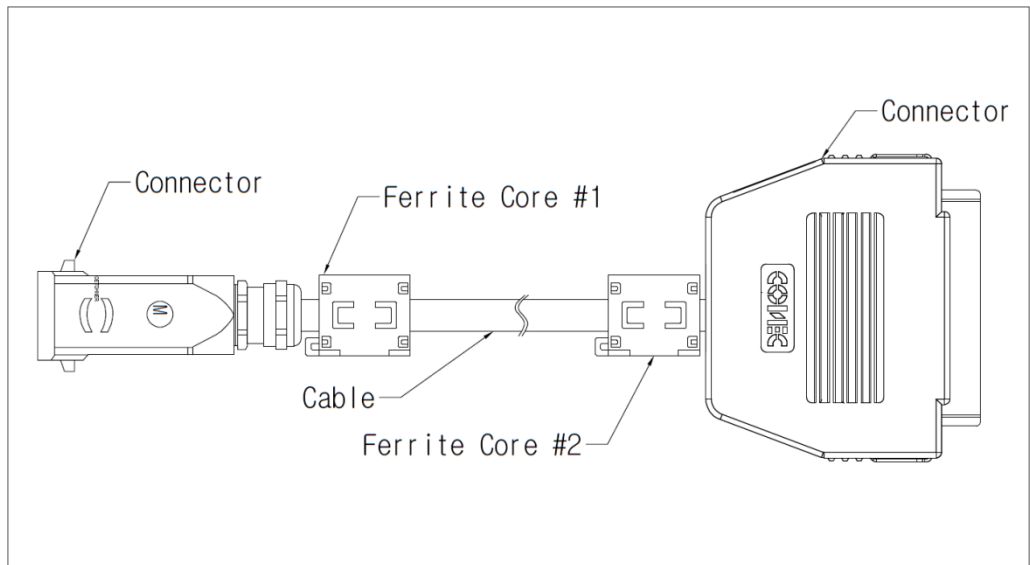

E.2.3.2 Connecting the Controller and Teach Pendant

Push the teach pendant cable into the corresponding controller connector until a click is heard to prevent the cable from becoming loose.

1 Connect the teach pendant cable to the controller connector

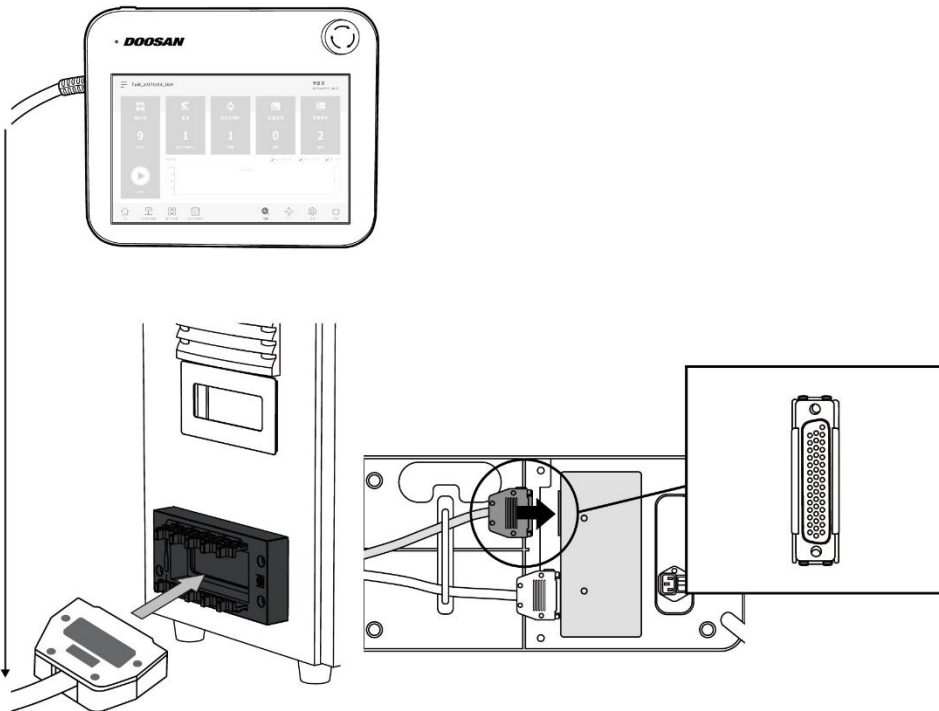

Caution

- Make sure that the pins of the cable end are not damaged or bent before connecting the cable.
- If the teach pendant is used by hanging on the AGV or on the controller, be careful not to trip on the connecting cables.
- Be careful not to allow the controller, teach pendant and cable come in contact with water.
- Do not install the controller and teach pendant in a dusty or wet environment.
- The controller and teach pendant must not be exposed to a dusty environment. Be especially careful in environments with conductive dust.

 **Note**

- When configuring the system, it is recommended that a noise reducer be installed to prevent noise effects and malfunction of the system.
- If the teach pendant is influenced by noise generated by electromagnetic waves, it is necessary to install a ferrite core to ensure normal operation. The installation location is as follows:

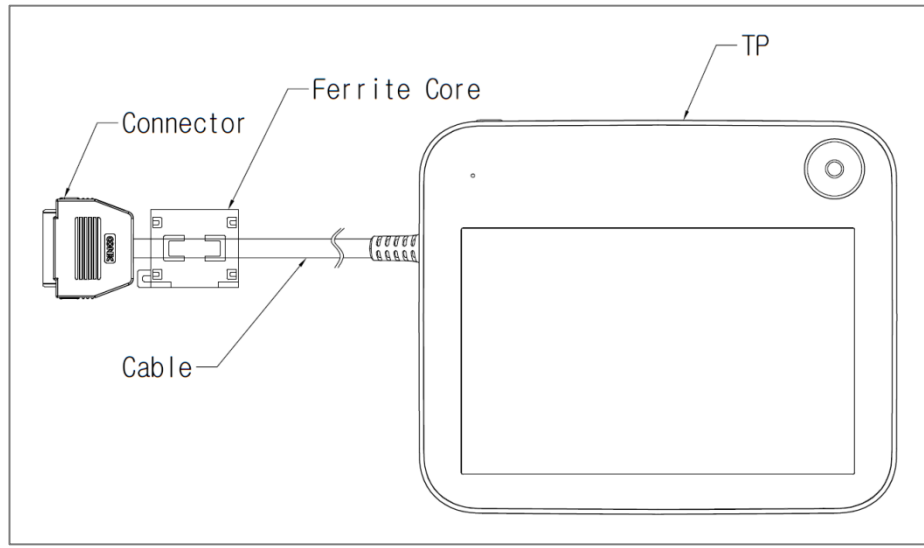

E.2.3.3 Routing of Manipulator Cable and Teach Pendant Cable

Ensure that the manipulator and teach pendant cable curvature radius is greater than the minimum curvature radius (120 mm).

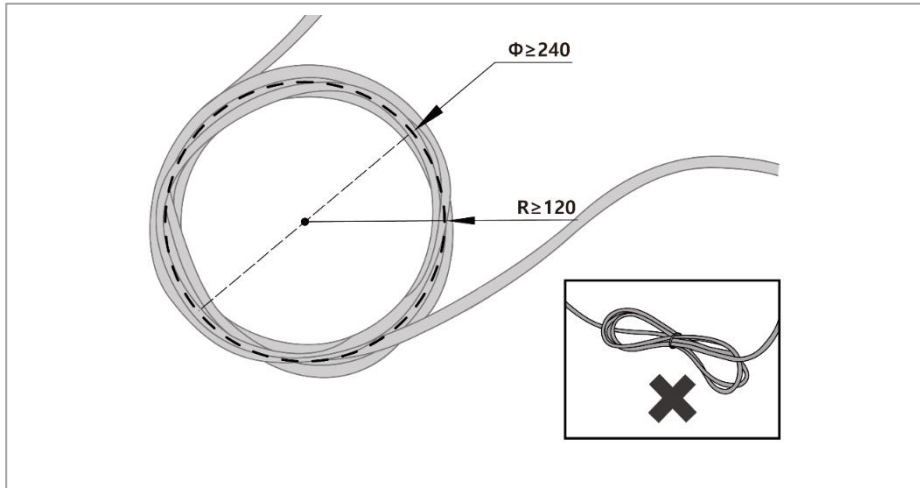

E.2.3.4 Supplying Power to the Controller

Push the power cable into the corresponding controller connector until a click is heard to prevent the cable from becoming loose.

1 Connect the supplying power cable to the controller connector

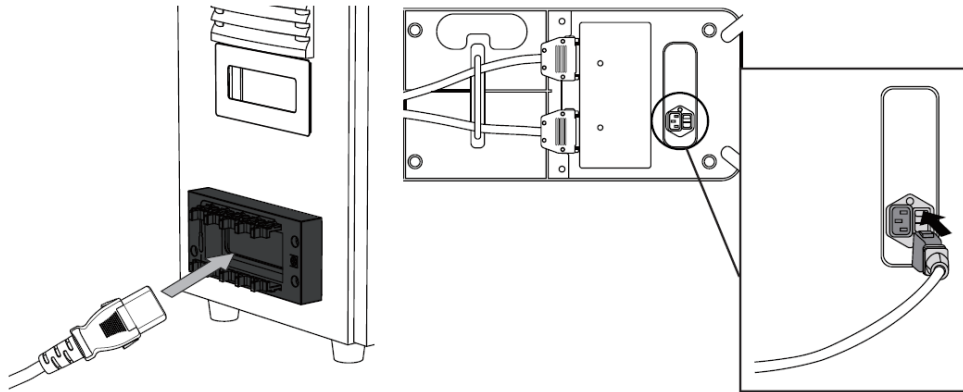

Warning

- After connecting the power cable, make sure that the robot has established a proper ground (electronic ground connection). Establish a common ground for all equipment in the system with an unused bolt related to the ground symbol inside the controller. The ground conductor must satisfy the maximum current rating of the system.
- Protect the input power of the controller using devices such as a circuit breaker.
- Do not modify or extend the robot cable. It can cause fire or controller breakdown.
- Make sure that all cables are properly connected before supplying power to the controller. Always use the original cable included in the product package.
- Be careful not to connect the polarity of the input voltage incorrectly.

 **Note**

- When configuring the system, it is recommended to install a power switch that can turn off power to all devices in the system at once.
- If the input voltage is less than 195V, the robot's movement may be limited according to the load and motion.
- The power supply must satisfy minimum requirements such as ground and circuit breakers. The electrical specifications are as follows: (If you selected an optional controller, check the instructions in the appendix)

Parameter	Specification
Input Voltage	100 – 240 VAC
Input Power Fuse (@100-240V)	15 A
Input Frequency	47 – 63 Hz

Annex F H-Series Handling Guide



Caution

1. Doosan Robotics does not assume responsibility for any damages caused by the use of lifting equipment.
2. If the robot is transported by packaging it with packaging materials, store the robot in a dry location. If the robot is stored in a location with high humidity, condensation may occur, resulting in robot defects.
3. When relocating the robot, carefully consider the weight and have a suitable number of people hold the link and base of the robot.
4. When relocating the controller, hold the handle on the side of the box.
5. When transporting the robot or controller, make sure to maintain the proper posture. Failure to do so may result in back injury or other physical injuries.
6. When transporting the robot using lifting equipment, make sure to observe all related national and regional regulations.
7. Doosan Robotics does not assume responsibility for any damages or losses that occur during transportation, so make sure to transport the robot safely according to the user manual.

Quick Guide

Thank you for choosing this Doosan Robotics product.

This guide provides the minimum amount of information required for three handling methods for relocation and installation of the H-Series robot safely. Make sure to follow the instructions in this guide when handling the robot.

- If the robot needs to be relocated, make sure to use the packaging materials provided with the initial delivery. For this purpose, store the packaging materials and fillings in a dry, cool location.
- Industrial robot's must be installed with careful consideration given to the inspection standards defined by the Regulations and Safety Inspection of the Occupational Safety and Health Standard Announcement (if the robot is subject to inspection).
- Lifting equipment must be used during the installation and relocation of the robot, and you must comply with the corresponding regional and national regulations when using lifting equipment.
- For installation and relocation of the robot, please refer to the packing posture.
- Make sure whether all standard and additional (optional) components are included, and contact the sales agent if there are any problems.
- The packaging materials and bolts are designed specifically for the relocation of the robot. Do not use them for any purposes other than relocating the robot.
- When relocating the robot, do not apply force to the exterior of the robot. Failure to comply with the instruction may result in injuries.
- Remove the packaging materials and bolts after installation. Make sure to store the packaging materials and bolts in case the robot needs to be relocated.
- Before relocation, make sure that the bolts and packaging materials are secure.



1. When Using Cranes

- The weight of the robot is approximately 70 kg. Use wire ropes capable of handling the weight of the robot.
- The length of the wire ropes must be at least 1500 mm, and it is recommended to support 4 points of the robot at least.

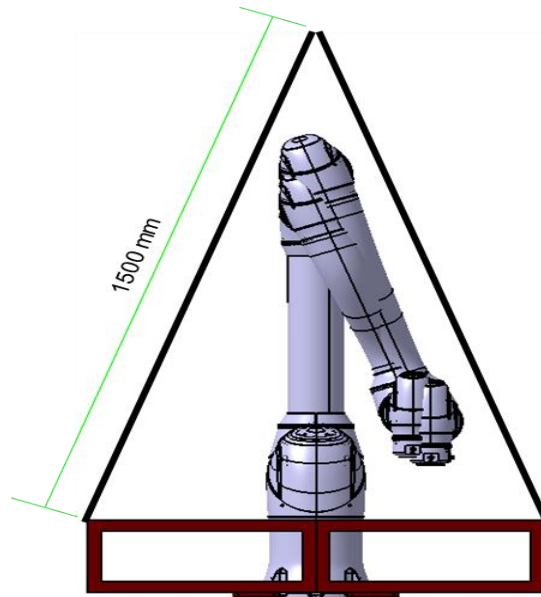

2. When Using Forklifts

- If the robot needs to be relocated in its packaged state, lift the bottom of the package using a forklift.
- When installation, relocate the robot using the lower packaging materials while taking caution to avoid damage to the robot.

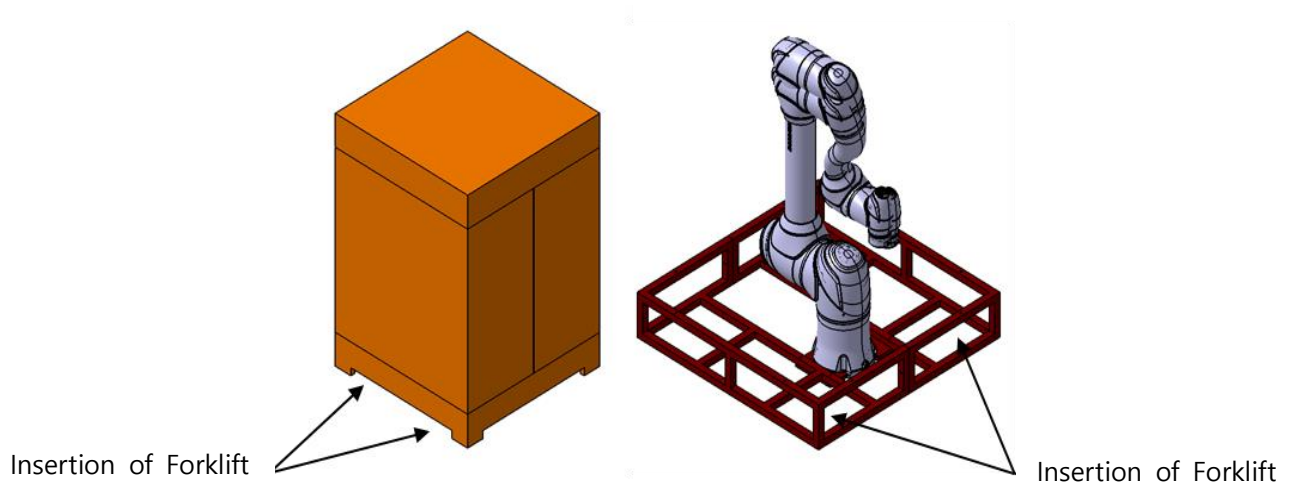

3. When Lifting Equipment is Unavailable

- If you need to relocate the robot due to the unavailability of lifting equipment, relocate the robot complying with the regional and national transport work standards.
- It is recommended to use the lower packaging materials as handles as below.

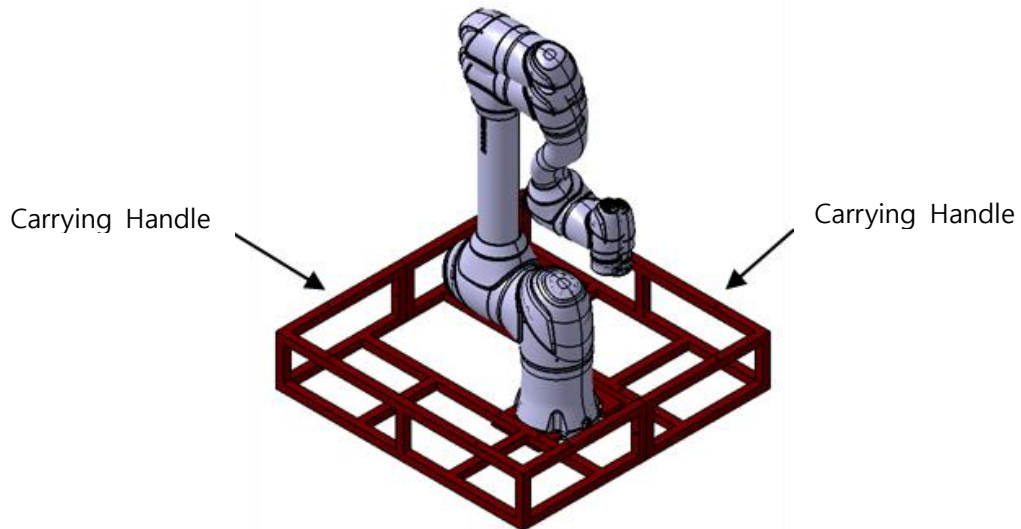

Note

For H-Series, four M8 Taps are applied to the base to facilitate handling.

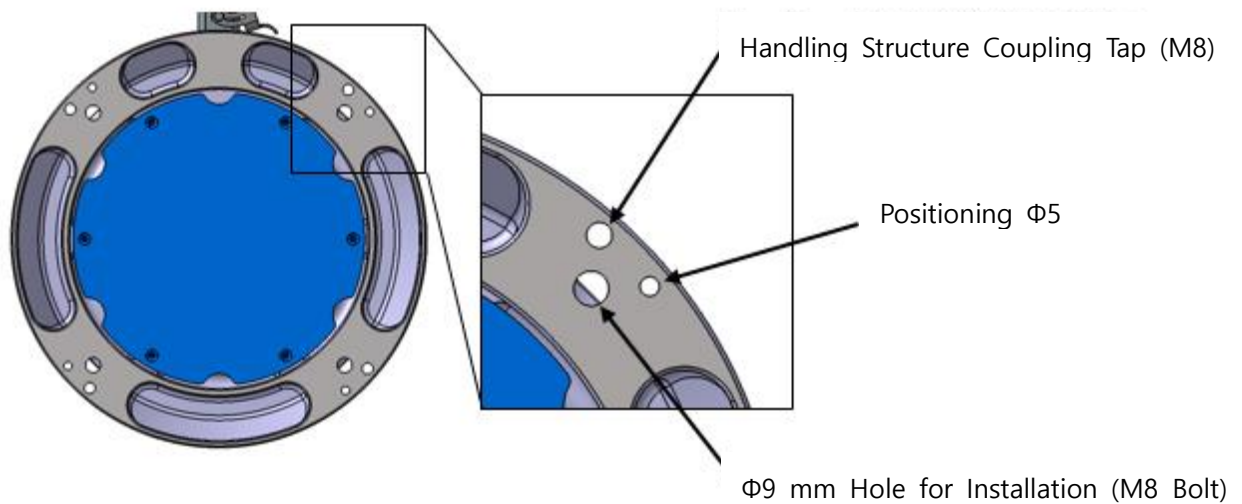



Doosan Robotics

www.doosanrobotics.com