

## Safety Light Curtain GL-R Series

# User's Manual



# Introduction

---

This user's manual describes handling, operation, and precautionary information for the GL-R Series Safety Light Curtain ("GL-R").



Read this user's manual thoroughly before operating the GL-R in order to understand the device features, and keep this user's manual readily available for reference. Ensure that the end user of this product receives this manual.

In this user's manual, "GL-RF" represents the finger protection type with the detection capability of  $\phi$  14 mm, "GL-RH" represents the hand protection type with the detection capability of  $\phi$  25 mm, "GL-RL" represents the body protection type with the detection capability of  $\phi$  45 mm and "GL-R" represents all the models including the GL-RF, GL-RH and GL-RL.

 See "Nomenclature of Model Name" (page 7-2)

## Symbols

The following symbols alert you to important messages. Be sure to read these messages carefully.

	<b>It indicates a hazardous situation which, if not avoided, will result in death or serious injury.</b>
	<b>It indicates a situation which, if not avoided, could result in product damage as well as property damage.</b>

---

 **It indicates additional information on proper operation.**

---

 It indicates tips for better understanding or useful information.

 Indicates reference pages in this or another manual.

# Safety Information for GL-R Series

## General precautions



- You must verify that the GL-R is operating correctly in terms of functionality and performance before the start of machine and the operation of the GL-R.
- KEYENCE does not guarantee the function or performance of the GL-R if it is used in a manner that differs from the GL-R specifications contained in this user's manual or if the GL-R is modified by the customer.
- When using the GL-R to protect machine operators against a hazard or hazardous zone or using the GL-R as a safety component for any purpose, always follow the applicable requirements of the laws, rules, regulations and standards in the country or region where the GL-R is used. For such regulations, you should directly contact the regulatory agency responsible for occupational safety and health in your country or region.
- Depending on the type of machine on which the GL-R is to be installed, there may be special safety regulations related to the use, installation, maintenance, and operation of the safety component. In such a case, you must fulfill such safety regulations. The responsible personnel must install the GL-R in strict compliance with such safety regulations.
- The responsible personnel must do the training to the assigned personnel for the correct use, installation, maintenance, and operation of the GL-R. "Machine operators" refers to personnel who have received appropriate training from the responsible personnel and are qualified to operate the machine correctly.
- Machine operators must have specialized training for the GL-R, and they must understand and fulfill the safety regulations in the country or region in which they are using the GL-R.
- When the GL-R fails to operate, machine operators must immediately stop the use of the machine and the GL-R and report this fact to the responsible personnel.
- The GL-R is designed with the assumption that it would be correctly installed in accordance with the installation procedures described in this user's manual and correctly operated according to the instructions in this user's manual. You must perform an appropriate installation of the GL-R after performing a sufficient risk assessment for the target machine.
- Be sure to absolutely confirm that there is nobody in the hazardous zone, before you remove the GL-R from the machine for replacement or disposal.
- When disposing the GL-R, always follow the applicable requirements of the laws, rules, regulations and standards in the country or region where the GL-R is used.
- The GL-R should be processed as an industrial waste product when being disposed.

## Precaution on use

### ■ Operators

	<ul style="list-style-type: none"><li>• In order to operate the GL-R correctly, the responsible personnel and machine operators must fulfill all of the procedures described in this user's manual.</li><li>• No person other than the responsible personnel and machine operators should be allowed to install or test the GL-R.</li><li>• When performing electrical wiring, always fulfill the electrical standards and regulations for the country or region in which the GL-R is used.</li></ul>
---	---

### ■ Environment of use

	<ul style="list-style-type: none"><li>• Do not use the GL-R in an environment (temperature, humidity, interfering light, etc.) that does not conform to the specifications contained in this user's manual.</li><li>• Be sure to confirm that the GL-R keeps normal operation when electromagnetic radiation is generated by wireless devices. (If you use wireless devices such as cellular phones or transceivers in the vicinity of the GL-R.)</li><li>• The GL-R is not designed to be explosion-proof. Never use it in the presence of flammable or explosive gases or elements.</li><li>• Be sure to confirm no deterioration in product quality if you use the GL-R in the presence of substances, such as heavy smoke, particulate matter, or corrosive chemical agents.</li><li>• Do not install the GL-R in areas where the GL-R is exposed to intense interference light such as direct sunlight, and direct or indirect light from an inverter-type fluorescent lamp (rapid-start type lamp, high-frequency operation type lamp, etc).</li><li>• Be sure to absolutely confirm that there is nobody in the hazardous zone, before the interlock is released (i.e. the machine system restarts) by the interlock reset mechanism. Failure to follow this warning results in significant harm to the machine operators, including serious injury or death.</li><li>• Be sure to absolutely confirm that there is nobody in the hazardous zone before the override function is activated. Failure to follow this warning results in significant harm to the machine operators, including serious injury or death.</li></ul>
--	--

### ■ Target machine

	<ul style="list-style-type: none"><li>• The GL-R has not undergone the model certification examination in accordance with Article 44-2 of the Japanese Industrial Safety and Health Law. The GL-R, therefore, cannot be used in Japan as a "Safety Device for Press and Shearing machines" as established in Article 42 of that law.</li><li>• The machine on which the GL-R is to be installed must be susceptible to an emergency stop at all operating points during its operation cycle. Do not use the GL-R for machines with irregular stop times.</li><li>• Do not use the GL-R for power presses equipped with full-revolution clutches.</li><li>• The GL-R cannot be used as a PSDI because it does not fulfill the requirements of OSHA 1910.217(h). Refer to OSHA 1910.217 for the PSDI mode.</li><li>• Do not use the GL-R to control (stop forward motion, etc.) trains, cars and other transportation vehicles, aircraft, equipment for use in space, medical devices, or nuclear power generation systems.</li><li>• The GL-R is designed to protect people or objects from going into/approaching detection zone against machine's hazard or hazardous zone. It cannot provide protection against objects or materials that are expelled from the machine's hazard or hazardous zone, so you must establish additional safety measures such as installing safeguards when there is the possibility of such projectiles.</li></ul>
---	---



## ■ Installation



- The GL-R must be installed only after ensuring the minimum safety distance between the GL-R and the hazardous zone or hazard as established by the applicable regulations in the country or region in which the GL-R is used. (e.g. EN ISO13855 (ISO 13855) in EU countries)
- Choose locations for the installation of the GL-R transmitters and receivers so that they are not subject to the effects of light reflected from glossy surfaces in the area.
- Correct operation and detection is not possible if the receiver has a different beam axis spacing (detection capability) from that of the transmitter. You must verify that the beam axis spacing (detection capability) is the same between the transmitter and the receiver when installing the GL-R.
- The GL-R must be installed so that the machine operator is able to go into or approach the hazardous zone or hazards only by passing through the detection zone of the GL-R. Strictly avoid installation that allows the machine operator or a part of the machine operator's body to go into or approach the hazardous zone or hazards without passing through the protective zone of the GL-R or to remain in position between the protective zone of the GL-R and the hazardous zone or hazard. In a case where you install the GL-R units in series (series connection), you must always check the installation carefully whether you follow this warning, especially after installation and maintenance.
- You must always perform the pre-check tests after installing the GL-R in accordance with the pre-check test procedures, such as items specified in this user's manual, in order to verify that the test pieces can be detected in all of the detection zones.
- Interlock reset mechanisms (such as switches) must be installed so that the entire hazardous zone can be checked by the responsible personnel. Interlock reset mechanisms should not be accessible from within the hazardous zone.
- Muting is a function to allow a temporary automatic suspension of the GL-R safety functions while the GL-R is receiving a signal from muting devices (such as sensors or switches). Therefore, additional safety measures are required for the machine on which the GL-R is installed in order to ensure safety while the muting is activated.
- Muting devices, the installation of those devices and the procedure to activate the muting function must fulfill the conditions specified in this user's manual and the requirements of the laws, rules, regulations and standards in the country or region in which the GL-R and those devices are used. Failure to follow this warning may result in significant harm to the machine operators, including serious injury or death.
- When you install muting devices (such as sensors or switches) for muting, the following conditions must be fulfilled.
  - (1) Muting devices must be installed so that the muting cannot be activated if the hazardous zone of the machine is in an unsafe condition or cycle.
  - (2) Muting devices must be installed so that the muting cannot be activated even if the personnel is accidentally approaching the detection zone of the GL-R.
- The muting device must be installed such that only responsible personnel have access to that device to change the installation or orientation. Special tools must be required to ensure that only responsible personnel are capable of installation, orientation or change of muting device.
- Only the responsible personnel may be allowed to install or wire the devices to activate the muting function.
- The installation of a muting lamp may be required by the laws, rules, regulations, and standards in the country or region in which the GL-R is used if you apply the muting function. It depends on the machine application and/or the result of your risk assessment. If it is necessary for you to provide a muting lamp, you must fulfill the requirements because you are fully responsible for installation of the muting lamp.



- The override devices, the installation of those devices and the procedures to activate the override must fulfill the conditions specified in this manual as well as the requirements of the laws, rules, regulations and standards in the country or region in which the GL-R and those devices are used. Failure to follow this warning may result in significant harm to the machine operators, including serious injury or death.
- The override devices, which are used for activation of override, must be manual operating devices. When installing the devices to activate the override, those devices must be installed so that the whole hazardous zone can be checked by the responsible personnel and so that it is not possible for machine operators to operate those devices in the hazardous zone.
- The installation of the indication for override may be required by the laws, rules, regulations, and standards in the country or region in which the GL-R is used if you apply the override function. It depends on the machine application and/or the result of your risk assessment. If it is necessary for you to provide the indication for override, you must fulfill the requirements because you are fully responsible for installation of the indication for override.
- The customer is fully responsible for complying with the requirements for muting and/or override. Those who use muting and/or override must fulfill all of the requirements related to muting and/or override. KEYENCE accepts NO responsibility and NO liability for any damage or any injury due to the unauthorized installation, usage or maintenance, which are not specified in this user's manual, and/or due to noncompliance with the laws, rules, regulations and standards in the country or region in which the GL-R is used.
- When the reduced resolution function is applied, the detection capability varies according to your configuration. Make sure to accurately calculate the safety distance according to the detection capability, and install the GL-R at a distance greater than or equal to the minimum safety distance away from the hazardous zone or hazard. The installation of additional safety measures, such as safeguarding, may be required if the detection capability varies due to the configuration of reduced resolution. On your own responsibility, you must perform the risk assessment based on your configuration of reduced resolution in order to reduce the risk.
- When the fixed blanking function is applied, a hazardous clearance that is not protected by the GL-R may be generated between the obstacle and the GL-R. You must install an additional safety measure such as a safeguard for this clearance.
- The override is a function to allow a temporary manual suspension of the safety functions of the GL-R. Therefore, additional safety measures are required for the whole machine system on which the GL-R is installed in order to ensure safety while the override is activated.
- Securely tighten mounting brackets and cable connectors used for the installation of the GL-R in accordance with the torque values specified in this user's manual.
- When optical synchronization system is applied and Channel A or B is configured, the response time is longer than the other case. Make sure to accurately calculate the safety distance according to the response time, and install the GL-R at a distance greater than or equal to the minimum safety distance away from the hazardous zone or hazard.

## ■ Circuit design and wiring



- Always turn off the power to the GL-R when performing electrical wiring.
- You must fulfill the electrical standards and regulations in the country or region in which the GL-R is being used when you perform the electrical wiring.
- To avoid the risk of electric shock, do not connect any of the GL-R inputs to DC power sources outside of the range of 24 V DC + 20% or to any AC power source.
- To avoid the risk of electric shock, be sure that any hazardous voltage is isolated from all wiring of the GL-R with reinforced insulation or double insulation.
- In order to fulfill the requirements in IEC61496-1, UL61496-1, EN61496-1 and UL508, the power supply for the GL-R must fulfill the conditions listed below.
  - (a) A rated output voltage of 24 V DC (SELV, Overvoltage Category II) within  $\pm 20\%$ .
  - (b) Double insulation or reinforced insulation between the primary and secondary circuits.
  - (c) Output holding time of 20 ms or more.
  - (d) A power supply must fulfill the requirements of the electrical safety and electromagnetic compatibility (EMC) regulations or standards in all countries and/or regions where the GL-R is used.
  - (e) A secondary circuit of power supply (output) must fulfill the requirements for Class 2 Circuits or Limited Voltage/Current Circuits specified in UL508, if the GL-R is used in the United States or Canada.
- Do not install the electric wiring of the GL-R together with or in parallel with any high-voltage electrical or power lines.
- Both OSSD outputs provided on the GL-R must be used to establish a safety-related machine control system. Establishing a safety-related machine control system with just one of the OSSD outputs cannot stop the machine due to an OSSD output malfunction and may result in significant harm to the machine operators, including serious injury or death.
- When using PNP output type cables, do not cause a short-circuit between the OSSD and +24 V. Otherwise, the OSSDs keep staying at the ON-state and it causes a dangerous situation.
- When using PNP output type cables, be sure to connect the load between the OSSD and 0 V to avoid a dangerous situation. If the load is incorrectly connected between the OSSD and +24 V, the logic of the OSSD operation will be reversed and the OSSD will change to an ON state when the GL-R detects an interruption in the detection zone. This is a dangerous situation.
- When using NPN output type cables, do not cause a short-circuit between the OSSD and 0 V. Otherwise, the OSSDs keep staying at the ON-state and it causes a dangerous situation.
- When using an NPN output type cable, be sure to connect the load between the OSSD and +24 V to avoid a dangerous situation. If the load is incorrectly connected between the OSSD and 0 V, the logic of the OSSD operation will be reversed and the OSSD will change to an ON state when the GL-R detects the interruption in the detection zone. This is a dangerous situation.
- Regardless of whether the cables are PNP or NPN type, you must fulfill the requirements of Clause 9.4.3 in IEC60204-1: 2005 for protection against maloperation due to earth fault.
- All outputs, other than OSSDs, are not allowed to be used as safety outputs for a safety-related machine control systems. Usage of these functions as safety outputs may result in significant harm to the machine operators, including serious injury or death.
- The wait input is not allowed to be connected to the output from any components comprising a part of the safety-related machine control system. If the wait input is connected to the output of a safety component it may result in significant harm to the machine operators, including serious injury or death.
- The transmitter and receiver cables must be within the lengths specified in this user's manual. Usage of cables longer than the specified length may cause the improper operation of safety functions and may cause a dangerous situation.

---

## Testing and maintenance



- You must always perform the pre-check test in accordance with the checklist, after maintenance, adjustment or alignment of the target machine or the GL-R and before the machine startup.
- If the GL-R does not operate properly when you perform a pre-check test in accordance with the checklist specified in this user's manual, do not operate the machine.
- You must periodically examine the machine to verify that all brakes, other stop mechanisms, and control devices operate reliably and correctly in addition to checking the GL-R.
- The responsible personnel must perform maintenance procedures as specified in this user's manual to ensure safety to the machine and GL-R.

---

## Precautions on Regulations and Standards

### ■ CE Marking

Keyence Corporation has confirmed that this product complies with the essential requirements of the applicable EC Directive, based on the following specifications.

Be sure to consider the following specifications when using this product in a member state of the European Union.

#### ● Machinery Directive (2006/42/EC)

The GL-R is a safety component as established by the European Union's Machinery Directive (2006/42/EC) Annex V. The GL-R complies with the following EN Standards and has been certified by TÜV SÜD Product Service GmbH.

- EN61496-1                      Type 4 ESPE
- EN61496-2                      Type 4 AOPD
- EN50178
- EN61508, Part 1 to 4        SIL3
- EN62061                        SIL CL3
- EN ISO13849-1                Category 4, PL e

#### ● EMC Directive (2004/108/EC)

The GL-R complies with the following EN Standards

- EN55011                        Class A
- EN61496-1                      Type 4 ESPE

These specifications do not give any guarantee that the end-product with this product incorporated complies with the essential requirements of EMC Directive. The manufacturer of the end-product is solely responsible for the compliance of the end-product itself according to the EMC Directive.

### ■ UL Certificate and North American Regulations

The GL-R complies with the following North American and international standards and has received UL certification and C-UL certification. (CCN: NIPF/NIPF7, File No: E184802)

- UL61496-1                      Type 4 ESPE
- UL61496-2                      Type 4 AOPD
- UL508
- UL1998

The GL-R also complies with the following North American regulations.

- FCC Part 15B                    Class A Digital Device
- ICES-003                        Class A Digital Apparatus

### ■ Model Certification Examination as a "Safety Devices for Presses and Shearing Machines"

The GL-R has not obtained the model certification examination in accordance with Article 44-2 of the Japanese Industrial Safety and Health Law. Therefore, the GL-R cannot be used in Japan as a "Safety Devices for Presses and Shearing Machines" as established in Article 42 of that law.

#### ● Other standards

The GL-R has been designed in consideration of the following standards and regulations. For details regarding the following standards, contact the third-party certification organization, such as UL or TÜV.

- EN60204-1
- EN692
- EN693
- OSHA 29 CFR 1910.212
- OSHA 29 CFR 1910.217
- ANSI B11.1 - B.11.19
- ANSI/RIA R15.06 - 1999
- SEMI S2
- "Guidelines for Comprehensive Safety Standards of Machinery", July 31, 2007, number 0731001 issued by Ministry of Health, Labor, and Welfare in Japan.

# Terms of License Agreement on Use of the Software

---

## ■ Software License Agreement

NOTICE TO USER: PLEASE READ THIS SOFTWARE LICENSE AGREEMENT (THIS “AGREEMENT”) CAREFULLY. BY USING ALL OR ANY PORTION OF THE [Safety Device Configurator, GL-R Configurator, SL-V Configurator, SZ Configurator, SZ-V Configurator] (THIS “SOFTWARE”), YOU ARE AGREEING TO BE BOUND BY ALL THE TERMS AND CONDITIONS OF THIS AGREEMENT. IF YOU DO NOT AGREE TO ANY TERMS OF THIS AGREEMENT, DO NOT USE THIS SOFTWARE.

### 1. Definition

- 1.1 “use” or “using” means to access, install, download, copy or otherwise benefit from using the functionality of this Software.
- 1.2 “This Software” means the software and all associated documentation provided by KEYENCE.

### 2. Grant of License.

Conditioned upon compliance with all of the terms and conditions of this Agreement, KEYENCE grants you a nonexclusive and nontransferable license to install this Software on all computers used by your entity in order to use the KEYENCE product. You may make one copy of this Software for backup or archive purposes only.

### 3. Restrictions.

- 3.1 Except for installation of updates or new functions provided by KEYENCE, you may not modify or add any function to this Software.
- 3.2 You may not reverse engineer, decompile or disassemble this Software.
- 3.3 You may not create derivative works based on this Software.
- 3.4 Other than expressly stated by KEYENCE, you may not resell, retransfer, rent or otherwise redistribute this Software to any third parties.

### 4. Intellectual Property Rights

Except as expressly stated herein, KEYENCE reserves all right, title and interest in this Software, and all associated copyrights, trademarks, and other intellectual property rights therein.

### 5. Disclaimer.

Keyence is licensing this Software to you “AS IS” and without any warranty of any kind. In no event will KEYENCE or its suppliers be liable to you for any damages, claims, costs or any lost profits caused by using this Software.

### 6. Termination.

- 6.1 Your license under this Agreement will terminate automatically if you destroy this Software and the copy of this Software in your possession or voluntarily return this Software to us.
- 6.2 Your license under this Agreement will terminate automatically without any notice from KEYENCE if you fail to comply with any of the terms and conditions of this Agreement. Promptly upon termination, you shall cease all use of this Software and destroy all copies, full or partial, of this Software in your possession or control.
- 6.3 You will compensate KEYENCE for costs or any lost profits caused by your violation or breach of any term of this Agreement.

### 7. Governing Law.

- 7.1 This Agreement will be governed by and construed in accordance with the substantive laws of Japan without regards to the principles of conflicts of law.
- 7.2 If any part of this Agreement is found void and unenforceable, it will not affect the validity of the balance of this Agreement, which shall remain valid and enforceable according to its terms and conditions.

# Table of Contents

<b>Introduction</b>	
Symbols	
<b>Safety Information for GL-R Series</b> .....	<b>1</b>
General precautions .....	1
Precaution on use .....	2
Testing and maintenance .....	6
Precautions on Regulations and Standards .....	7
<b>Terms of License Agreement on Use of the Software</b> .....	<b>8</b>
<b>Table of Contents</b> .....	<b>9</b>

## Chapter 1 Before Use

<b>1-1 Products</b> .....	<b>1-2</b>
Light curtain unit .....	1-2
Cables .....	1-2
Mounting brackets .....	1-5
Antivibration bracket .....	1-6
Front protection cover .....	1-7
Corner mirror .....	1-8
Laser Alignment Tool for GL-R (Model: GL-R1LP) .....	1-8
Software and Interface Unit .....	1-9
Dedicated Safety Reley for the GL-R Series (Model: GL-T11R) .....	1-9
<b>1-2 Part Description</b> .....	<b>1-10</b>

## Chapter 2 Functions and Features

<b>2-1 Wiring System</b> .....	<b>2-2</b>
Wiring system .....	2-2
Series connection .....	2-3
<b>2-2 Functions</b> .....	<b>2-4</b>
Availability of functions which can be configured by the configuration software .....	2-5
<b>2-3 OSSD</b> .....	<b>2-6</b>
<b>2-4 Interlock Function</b> .....	<b>2-7</b>
Configuration method .....	2-7
Details of operation mode .....	2-8
Wiring .....	2-9
Time chart .....	2-10
<b>2-5 External Device Monitoring (EDM Function)</b> .....	<b>2-12</b>
Wiring .....	2-12
Time chart .....	2-12
<b>2-6 Temporary Suspension of Safety Function</b> .....	<b>2-13</b>
Muting function .....	2-13
Devices used for muting function .....	2-14
Detailed operation .....	2-14
Partial muting function / Muting bank function .....	2-16
Changing configuration of the muting function .....	2-17
Example: Muting function with 2 muting devices (Sensors) .....	2-18
Example: Muting function with 4 muting devices .....	2-21

Example: Muting function with 2 muting devices (Switches) .....	2-25
Override function .....	2-28
Override Function Settings .....	2-30
<b>2-7 Fixed Blanking .....</b>	<b>2-31</b>
<b>2-8 Reduced Resolution .....</b>	<b>2-32</b>
How to use .....	2-33
Procedure for Configuration .....	2-33
<b>2-9 Wait Input Function .....</b>	<b>2-34</b>
<b>2-10 Non Safety-Related Outputs .....</b>	<b>2-36</b>
AUX (Auxiliary) output (Default function on the red wire of the receiver cable) .....	2-37
Error output (Default function on the black wire of the transmitter cable) .....	2-37
Muting lamp output (The red wire of the transmitter cable) .....	2-38
Muted condition output .....	2-38
Alert output .....	2-39
Clear / Blocked output .....	2-40
Interlock reset ready output .....	2-40

## Chapter 3 Installation to a Machine

<b>3-1 Correct Installation Method .....</b>	<b>3-2</b>
Transmitter and receiver orientation .....	3-2
Mounting position .....	3-3
<b>3-2 Safety Distances .....</b>	<b>3-4</b>
<b>3-3 Light Interference Prevention Method .....</b>	<b>3-8</b>
Light Interference Prevention Function .....	3-8
Series connection .....	3-8
Interference due to installation .....	3-8
<b>3-4 Installation Distance from Glossy Surfaces .....</b>	<b>3-10</b>
<b>3-5 Cable Installation .....</b>	<b>3-11</b>
Overview .....	3-11
Cable connection to the lower part of the GL-R (The unit connection cable and extension cable) .....	3-12
Cable connection to the upper part of the GL-R (The series connection cable) .....	3-12
<b>3-6 Mounting Brackets .....</b>	<b>3-13</b>
Adjustable angle mounting bracket (GL-RB01/GL-RB02) .....	3-13
Straight mounting bracket (GL-RB11) / L-shaped mounting bracket (GL-RB12) .....	3-14
No dead zone mounting bracket (GL-RB21) .....	3-15
Antivibration bracket for the adjustable angle mounting bracket (GL-RB32) .....	3-16
Antivibration bracket for the straight mounting bracket (GL-RB31) .....	3-17
<b>3-7 Front Protection Cover .....</b>	<b>3-18</b>
<b>3-8 Optical Alignment .....</b>	<b>3-19</b>
Ensure the following prior to optical alignment .....	3-19
Alignment procedure .....	3-19
Alignment using laser alignment tool .....	3-20

## Chapter 4 Wiring

<b>4-1 Precautions on Wiring and Power Supply .....</b>	<b>4-2</b>
Power supply .....	4-2



<b>4-2</b>	<b>I/O Circuit Diagram</b> .....	<b>4-3</b>
<b>4-3</b>	<b>Cable Color and Pin Position</b> .....	<b>4-4</b>
	Pin position (default) .....	4-4
	Pin position (when not default output functions are assigned) .....	4-6
<b>4-4</b>	<b>Cable Specification</b> .....	<b>4-8</b>
<b>4-5</b>	<b>Examples of Wiring</b> .....	<b>4-9</b>
	Symbols .....	4-9
	Optical synchronization system .....	4-10
	One-line system .....	4-14
	Wire synchronization system .....	4-16

## Chapter 5 Indicators

<b>5-1</b>	<b>Function Indicators and 7-segment Display</b> .....	<b>5-2</b>
	Function indicators .....	5-2
	7-segment display .....	5-3
<b>5-2</b>	<b>Center Indicator</b> .....	<b>5-4</b>
	Overview .....	5-4
	Changing the Indication Method for the Center indicator .....	5-5

## Chapter 6 Setting Method Using the Configuration Software

<b>6-1</b>	<b>Before Use</b> .....	<b>6-2</b>
	About the configuration software .....	6-2
	System Requirements .....	6-2
<b>6-2</b>	<b>Installing the configuration software</b> .....	<b>6-3</b>
	Before Installation .....	6-3
	Downloading the configuration Software .....	6-3
	Installation Procedure .....	6-4
	Uninstalling each software .....	6-4
	Note for Windows 7/8/8.1/10 .....	6-4
<b>6-3</b>	<b>Connecting the GL-R Main Unit and PC</b> .....	<b>6-5</b>
	Part Names .....	6-5
	Connection Method .....	6-6
<b>6-4</b>	<b>Main Screen Part Names</b> .....	<b>6-7</b>
	Menu bar .....	6-7
	Tool bar .....	6-7
	Tab .....	6-8
	Main area .....	6-8
<b>6-5</b>	<b>Starting and Exiting the GL-R Configurator</b> .....	<b>6-9</b>
	Starting the <GL-R Configurator> .....	6-9
	Exiting the <GL-R Configurator> .....	6-11
<b>6-6</b>	<b>Login/Logout</b> .....	<b>6-12</b>
	Login .....	6-12
	Logout .....	6-12
<b>6-7</b>	<b>Uploading the Configuration Data</b> .....	<b>6-13</b>
<b>6-8</b>	<b>Saving the Configuration Data</b> .....	<b>6-15</b>

	Saving the configuration data .....	6-15
	Opening the saved configuration .....	6-15
<b>6-9</b>	<b>Configuration Tab .....</b>	<b>6-16</b>
	Unit configuration .....	6-16
	Safety function .....	6-17
	Non-safety function .....	6-22
<b>6-10</b>	<b>Monitor Tab .....</b>	<b>6-23</b>
	I/O monitoring .....	6-24
	OFF information .....	6-25
	Error information .....	6-26
<b>6-11</b>	<b>Other Functions .....</b>	<b>6-27</b>
	File (F) .....	6-27
	Communication (C) .....	6-28
	Log-in authentication (A) .....	6-29
	Language (L) .....	6-29
	Help (H) .....	6-30

## Chapter 7 Specifications and Dimensions

<b>7-1</b>	<b>Nomenclature of Model Name .....</b>	<b>7-2</b>
	Transmitter and receiver unit .....	7-2
	Cable .....	7-2
<b>7-2</b>	<b>Specifications .....</b>	<b>7-3</b>
	Specifications .....	7-3
	Response time (OSSD) .....	7-5
	Current consumption .....	7-7
	Weight .....	7-7
	Packaged items and materials .....	7-10
<b>7-3</b>	<b>Dimensions .....</b>	<b>7-12</b>
	GL-RF/RH/RL unit .....	7-12
	Adjustable angle mounting bracket (Model: GL-RB01) .....	7-14
	Adjustable angle mounting bracket (Model: GL-RB02) .....	7-14
	Straight mounting bracket (Model: GL-RB11) .....	7-15
	L-shaped mounting bracket (Model: GL-RB12) .....	7-15
	No dead zone mounting bracket (Model: GL-RB21) .....	7-16
	Antivibration bracket for the adjustable angle mounting bracket (Model: GL-RB32) .....	7-16
	Antivibration bracket for the straight mounting bracket (Model: GL-RB31) .....	7-17
	Front protection cover (Model: GL-RA□) .....	7-18
	Interface unit (Model: GL-R1UB) .....	7-18

## Appendix

<b>1</b>	<b>Troubleshooting .....</b>	<b>A-2</b>
	Error condition .....	A-2
	If the device is in the error condition .....	A-4
	If the GL-R is not in an error condition .....	A-7
<b>2</b>	<b>Checklist .....</b>	<b>A-8</b>
	Checklist before operation .....	A-8

# 1

## Before Use

---

---

1-1	Products .....	1-2
1-2	Part Description .....	1-10

### Light curtain unit

#### ■ GL-RF/RH/RL

- GL-R transmitter (Transmitter) × 1
- GL-R receiver (Receiver) × 1
  
- Test piece × 1
  - GL-RF : Diameter of 14 mm, Length of 200 mm
  - GL-RH : Diameter of 25 mm, Length of 200 mm
  - GL-RL : The test piece is not supplied. Please acquire on yourself.
  
- Instruction manual

### Cables

#### ! Point

- Each model is connected to one cable. Therefore, at least two cables are needed as a system, one for the transmitter and another for the receiver.
- All cables can be used for both the transmitter and receiver.
- The combination of the wiring system and cable determines the functions that can be used. Different types of cables can be used for the transmitter and receiver.
  - ☞ "2-1 Wiring System" (page 2-2)
  - ☞ "2-2 Functions" (page 2-4)
- Be sure to match the numbers of conductors (core wires) when using the unit connection cable for extension use and the extension cable.

#### ■ Unit connection cable

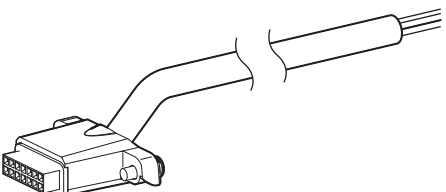
Shape	Model	Number of core	Length	Output type
 <p>Brown and blue: AWG22 (nominal cross-sectional area of 0.34 mm<sup>2</sup>) Others: AWG26 (nominal cross-sectional area of 0.14 mm<sup>2</sup>)</p>	GL-RP5P	5	5 m	PNP
	GL-RP5PS	7		
	GL-RP5PM	11		
	GL-RP10P	5	10 m	
	GL-RP10PS	7		
	GL-RP10PM	11		
	GL-RP5N	5	5 m	NPN
	GL-RP5NS	7		
	GL-RP5NM	11		
	GL-RP10N	5	10 m	
	GL-RP10NS	7		
	GL-RP10NM	11		

## ■ Unit connection cable (for extension use)

Used together with the extension cable.

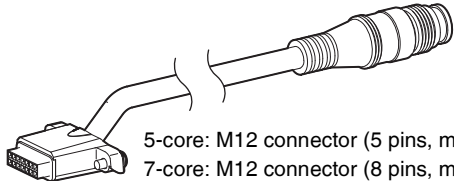
Shape	Model	Number of core	Length	Output type
 <p>5-core: M12 connector (5 pins, male) 7-core: M12 connector (8 pins, male) 11-core: M14 connector (12 pins, male)</p>	GL-RPC03P	5	0.3 m	PNP
	GL-RPC03PS	7		
	GL-RPC03PM	11		
	GL-RPC03N	5		NPN
	GL-RPC03NS	7		
	GL-RPC03NM	11		

## ■ Extension cable

Used together with the unit connection cable for extension use.

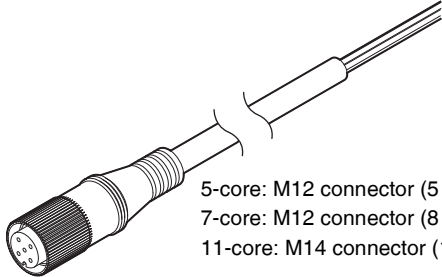
Shape	Model	Number of core	Length	Output type
 <p>5-core: M12 connector (5 pins, female) 7-core: M12 connector (8 pins, female) 11-core: M14 connector (12 pins, female)</p> <p>Brown and blue: AWG22 (nominal cross-sectional area of 0.34 mm<sup>2</sup>) Others: AWG26 (nominal cross-sectional area of 0.14 mm<sup>2</sup>)</p>	GL-RC5	5	5 m	PNP/ NPN
	GL-RC5S	7		
	GL-RC5M	11		
	GL-RC10	5	10 m	
	GL-RC10S	7		
	GL-RC10M	11		
	GL-RC20	5	20 m	
	GL-RC20S	7		
	GL-RC20M	11		

## ■ Series connection cable

Used for one-line system or series connection.

📖 "Wiring system" (page 2-2)

📖 "Series connection" (page 2-3)

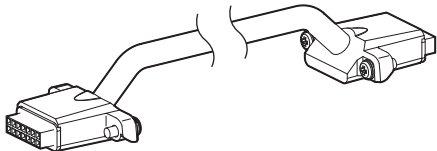
Shape	Model	Length	Output type
 <p>Two connectors are identical. Direction of connection is not specified.</p>	GL-RS008	0.08 m	PNP/ NPN
	GL-RS015	0.15 m	
	GL-RS05	0.5 m	
	GL-RS1	1 m	
	GL-RS3	3 m	
	GL-RS5	5 m	
	GL-RS10	10 m	

## Cable length specification

1. Optical synchronization system, wire synchronization system  
The sum of the length of unit connection cable and extension cable must be 30 m or less. This limitation applies separately to the entire transmitter cable setup and the entire receiver cable setup. There is no limitation for the total length of series connection cables when the GL-R is connected in series.
2. One-line system  
The sum of the length for all cables including unit connection cable, extension cable and series connection cable must be 30 m or less.



**Cables must be within the lengths specified. Failure to follow this specification may cause improper operation of safety functions, and may create a dangerous situation.**

## Mounting brackets

📖 "3-6 Mounting Brackets" (page 3-13)

### ■ Adjustable angle mounting bracket (GL-RB01)

Materials: SPHC

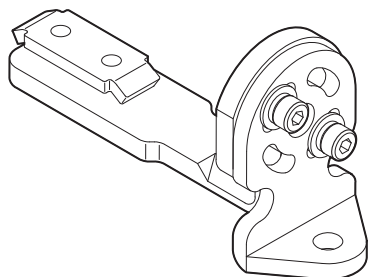

### ■ Adjustable angle mounting bracket (GL-RB02)

Materials: SPHC

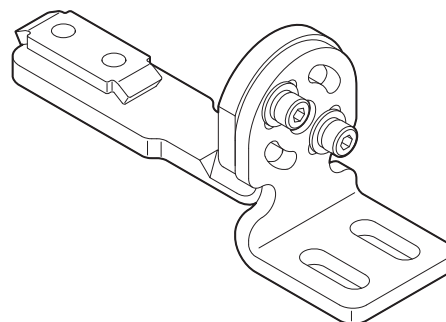

### ■ Straight mounting bracket (GL-RB11)

Materials: SPHC

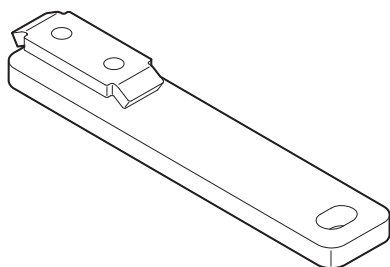

### ■ L-shaped mounting bracket (GL-RB12)

Materials: SPHC

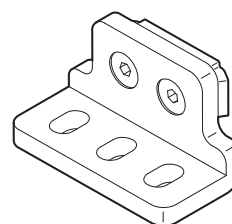

### ■ No dead zone mounting bracket (GL-RB21)

Materials: Zinc die-cast

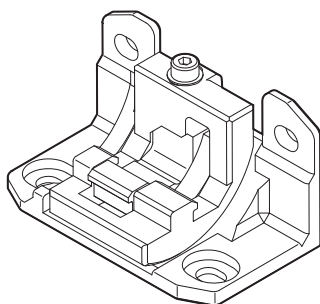

## Antivibration bracket

📖 "3-6 Mounting Brackets" (page 3-13)

- **Antivibration bracket for the adjustable angle mounting bracket (GL-RB32)**

Materials: SPHC, EPDM

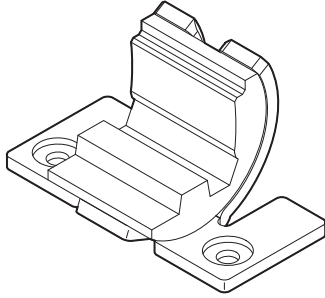

- **Antivibration bracket for the straight mounting bracket (GL-RB31)**

Materials: EPDM

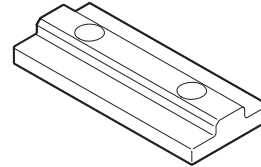

**! Point**

If the length for a single GL-R unit is 1280 mm or greater, use the following antivibration bracket additionally as an intermediate support bracket. The antivibration bracket must be selected according to the mounting bracket and installed on the center of the GL-R unit.

Mounting bracket	Antivibration bracket
Adjustable angle mounting bracket	Antivibration bracket for the adjustable angle mounting bracket
No dead zone mounting bracket	
Straight mounting bracket	Antivibration bracket for the straight mounting bracket
L-shaped mounting bracket	L-shaped mounting bracket

For more information about the mounting position of the antivibration brackets, see 📖 "Dimensions" (page 7-12).



## Front protection cover

KEYENCE can provide a front protection plastic cover to protect the surface of the GL-R.

📖 "Front Protection Cover" (page 3-18)



Model	Applicable model		
GL-RA160	–	GL-R08H	GL-R04L
GL-RA240	GL-R23F	GL-R12H	GL-R06L
GL-RA320	GL-R31F	GL-R16H	GL-R08L
GL-RA400	GL-R39F	GL-R20H	GL-R10L
GL-RA480	GL-R47F	GL-R24H	GL-R12L
GL-RA560	GL-R55F	GL-R28H	GL-R14L
GL-RA640	GL-R63F	GL-R32H	GL-R16L
GL-RA720	GL-R71F	GL-R36H	GL-R18L
GL-RA800	GL-R79F	GL-R40H	GL-R20L
GL-RA880	GL-R87F	GL-R44H	GL-R22L
GL-RA960	GL-R95F	GL-R48H	GL-R24L
GL-RA1040	GL-R103F	GL-R52H	GL-R26L
GL-RA1120	GL-R111F	GL-R56H	GL-R28L
GL-RA1200	GL-R119F	GL-R60H	GL-R30L
GL-RA1280	GL-R127F	GL-R64H	GL-R32L
GL-RA1440	–	GL-R72H	–
GL-RA1600	–	GL-R80H	–
GL-RA1760	–	GL-R88H	–
GL-RA1920	–	GL-R96H	–

**!** Point

When the front protection cover is installed, the maximum operating distance is shortened as follows.

Number of front protection cover installed	Maximum operating distance		
	GL-RF	GL-RH	GL-RL
One cover (on the transmitter or receiver)	9.5 m	14.5 m	
Two covers (on the transmitter and receiver)	9 m	14 m	

## Corner mirror

The corner mirror reflects the light beam from the transmitter to the receiver. The angle of reflection is from 45 to 95 degrees. Up to four mirrors can be used.

📖 See "SL-M Series Instruction Manual"

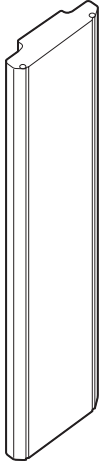

Model	Applicable model		
SL-M12H	GL-R23F	GL-R08H/GL-R12H	GL-R04L/GL-R06L
SL-M16H	GL-R31F	GL-R16H	GL-R08L
SL-M20H	GL-R39F	GL-R20H	GL-R10L
SL-M24H	GL-R47F	GL-R24H	GL-R12L
SL-M28H	GL-R55F	GL-R28H	GL-R14L
SL-M32H	GL-R63F	GL-R32H	GL-R16L
SL-M36H	GL-R71F	GL-R36H	GL-R18L
SL-M40H	GL-R79F	GL-R40H	GL-R20L
SL-M44H	GL-R87F	GL-R44H	GL-R22L
SL-M48H	GL-R95F	GL-R48H	GL-R24L
SL-M52H	GL-R103F	GL-R52H	GL-R26L
SL-M56H	GL-R111F	GL-R56H	GL-R28L
SL-M60H	GL-R119F	GL-R60H	GL-R30L
SL-M64H	GL-R127F	GL-R64H	GL-R32L
SL-M80H	-	GL-R72H/GL-R80H	-
SL-M96H	-	GL-R88H/GL-R96H	-

! Point

The operating distance is shortened at a rate of approx. 10% per corner mirror.

## Laser Alignment Tool for GL-R (Model: GL-R1LP)

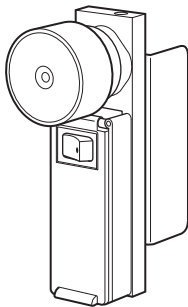

This is a tool to assist alignment of the optical axis when installing the GL-R. For details, 📖 see "3-8 Optical Alignment" (page 3-19).

**NOTICE**

The GL-R1LP is a tool to assist alignment of the optical axis; it does not guarantee perfect alignment. After roughly aligning the optical axis with the GL-R1LP, if the alignment is not perfect, adjust the optical axis according to the procedure described in 📖 "3-8 Optical Alignment" (page 3-19).

## Software and Interface Unit

In order to configure the GL-R by the personal computer, the following items are necessary.

📖 "Chapter 6 Setting Method Using the Configuration Software" (page 6-1)

### ■ Configuration software <Safety Device Configurator>

The configuration software can be downloaded from the KEYENCE website.

<http://www.keyence.com>

If you can not access the internet, call the nearest KEYENCE office.

### ■ Interface unit (GL-R1UB)

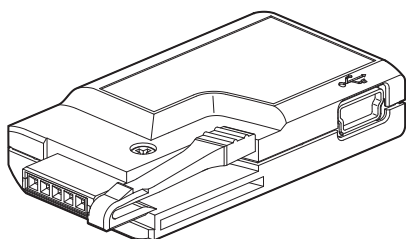

#### ! Point

USB cable to connect the interface unit and the personal computer is not supplied. Please acquire [A: miniB] type USB cable on yourself.  
(You can also use the following option USB cables)

### ■ USB cable 2 m (OP-51580)

### ■ USB cable 5 m (OP-86941)

## Dedicated Safety Relay for the GL-R Series (Model: GL-T11R)

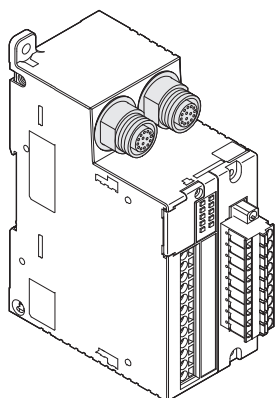

Relay terminal to convert control output to contact relay. Connection between GL-R and GL-T11R is made using the dedicated connector cable. Each I/O line of GL-R is assigned to each terminal block of GL-T11R. For details, refer to 📖 "GL-T11R Instruction Manual".

#### ! Point

For connection between GL-R and GL-T11R, the cable shown on 📖 "Cables" (page 1-2) cannot be used.

# 1-2 Part Description

1

Before Use

## ■ Transmitter

## ■ Receiver

## ■ Back side

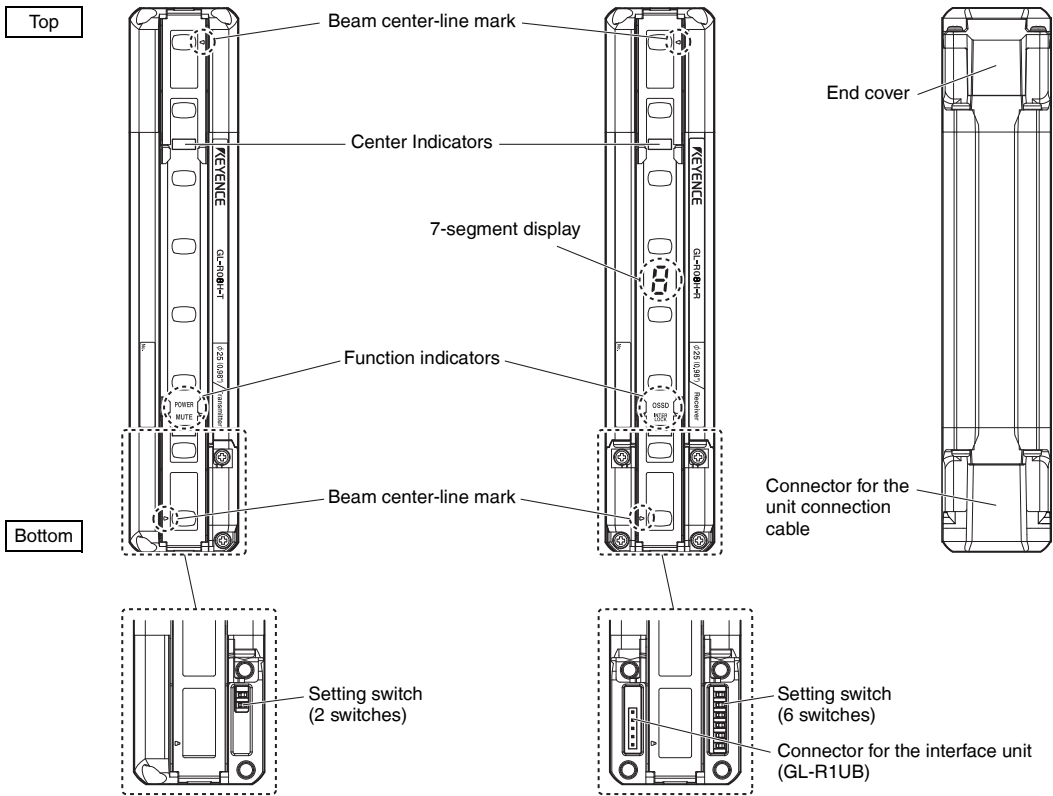

\*1 The side where the end cover has already been installed at shipment is the top side.

## ■ Setting switch

### Transmitter

Switch No.	Function	Configuration
2	Channel	Channel 0 (Not applied) (Default) Use Channel for light interference prevention when optical synchronization system is applied. For details, refer to
		Channel A "Light Interference Prevention Function" (page 3-8)
1	Channel B	Channel B "Light Interference Prevention Function" (page 3-8)

### Receiver

Switch No.	Function	Configuration
6	Center indicator	ON (Green) when all beam axes are clear (Default).
		OFF when all beam axes are clear. (Green OFF)
5	Reduced resolution (Safety-related function)	Reduced resolution is not applied (Default).
4		Reduced resolution (one optical beam) is applied.
3		Reduced resolution (two optical beams) is applied.
2	Channel	Channel 0 (Not applied) (Default) Use Channel for light interference prevention when optical synchronization system is applied. For details, refer to
		Channel A "Light Interference Prevention Function" (page 3-8)
1	Channel B	Channel B "Light Interference Prevention Function" (page 3-8)

	<ul style="list-style-type: none"> <li>• The response time varies according to the configuration of Channel.               <ul style="list-style-type: none"> <li>☞ "Response time (OSSD)" (page 7-5)</li> </ul> </li> <li>• The detection capability varies according to the configuration of reduced resolution.               <ul style="list-style-type: none"> <li>☞ "Reduced Resolution" (page 2-32)</li> </ul> </li> </ul>
--	---

#### ! Point

- The configuration of the setting switch is applied when the power is supplied.
- When the GL-R is in series connection, the setting switch configuration of the main unit is applied regardless of the setting switch configuration of the sub unit.
- When the center indicator and reduced resolution are configured by using the configuration software, the setting switch must be configured by default. Otherwise an error occurs.
  - ☞ "Chapter 6 Setting Method Using the Configuration Software" (page 6-1)
- When the GL-R operates in wire synchronization system, the setting switch for Channel must be configured by default. Otherwise an error occurs.
  - ☞ "Wiring System" (page 2-2)

☞ "Center Indicator" (page 5-4)

☞ "Reduced Resolution" (page 2-32)

**Beam center-line:** An optical path joining the optical center of the emitting element on the transmitter to the optical center of the corresponding receiving element on the receiver. The GL-R must be installed so that the beam center-line mark on the transmitter and that on the receiver face one another and are located at the same height.

**Detection height:** The height from the top beam center-line to the bottom beam center-line (length).

**Protection height:** An object approaching the detection zone from the top of the detection height is first detected at point A, which is the distance of the detection capability from the top of the detection height. The equivalent position on the bottom is called point B. The height from the top edge of the specified target detection capability that exists at point A to the bottom edge of the specified target detection capability that exists at point B is called the "protection height".

The following calculation formula can be defined:

$$\text{Protection height} = \text{"Detection height"} + (2 \times \text{"specified target detection capability"}) - \text{"beam axis diameter"}$$

\* Refer to the following diagram for an explanation of beam center-line, detection height and protection height.

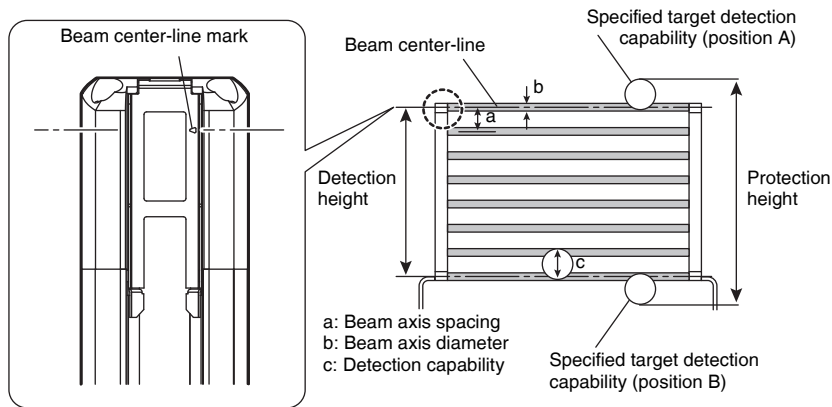

**Detection zone:** The zone in which the specified target detection capability can be detected. The detection zone of the GL-R indicates a square area formed with the detection height and the operating distance. When an object of the specified target detection capability is present in this area, the light of the GL-R is blocked, and then the OSSD goes to OFF state.

**Protection zone:** The square area formed with the protection height and the operating distance, which is broader than the detection zone. When an object of the specified target detection capability is present in this area, the light of the GL-R is blocked, and then the OSSD goes to OFF state.

\* Refer to the following diagram for detection zone and protection zone.

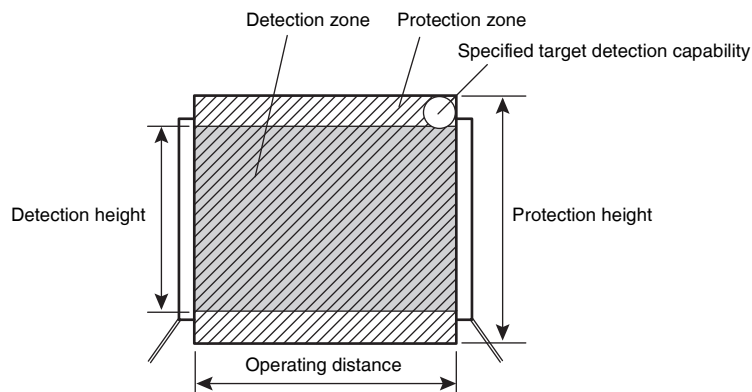

# 2

## Functions and Features

---

---

2-1	Wiring System . . . . .	2-2
2-2	Functions . . . . .	2-4
2-3	OSSD . . . . .	2-6
2-4	Interlock Function . . . . .	2-7
2-5	External Device Monitoring (EDM Function) . . . . .	2-12
2-6	Temporary Suspension of Safety Function . . . . .	2-13
2-7	Fixed Blanking . . . . .	2-31
2-8	Reduced Resolution . . . . .	2-32
2-9	Wait Input Function . . . . .	2-34
2-10	Non Safety-Related Outputs . . . . .	2-36

# 2-1 Wiring System

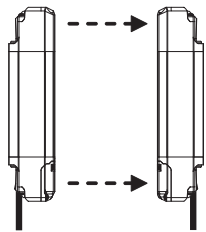
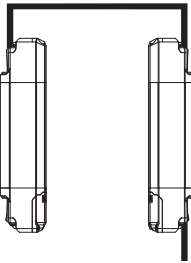
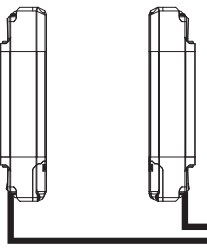

The following three types of wiring systems and the series connection are available in the GL-R series.

## Wiring system

Wiring system		Optical synchronization system	One-line system	Wire synchronization system
Wiring diagram				
Advantage		<ul style="list-style-type: none"> <li>Wiring is not needed between the transmitter and receiver.</li> <li>The Transmitter and the receiver can operate on different power supplies.</li> </ul>	<ul style="list-style-type: none"> <li>Simplified wiring.</li> <li>The unit connection cable is not needed for the transmitter.</li> </ul>	<ul style="list-style-type: none"> <li>All functions of the GL-R are available.</li> </ul>
Limitation		<ul style="list-style-type: none"> <li>The input and output functions on the transmitter are not available.</li> <li>All indicators other than "Power" are not available on the transmitter.</li> </ul>	<ul style="list-style-type: none"> <li>The input and output functions on the transmitter are not available.</li> <li>There is a maximum limit for the total length of cables.</li> </ul>	<ul style="list-style-type: none"> <li>Wiring is needed between the transmitter and the receiver.</li> </ul>
Applicable cable	Transmitter	5-core cable	Series connection cable	7-core cable 11-core cable
	Receiver	5-core cable 11-core cable	5-core cable 11-core cable	7-core cable 11-core cable

### Reference

Available functions are determined according to the combination of the wiring system and cables. Refer  "2-2 Functions" (page 2-4) for the available function and select the wiring system and cables.

-  "Cables" (page 1-2)
-  "2-2 Functions" (page 2-4)
-  "4-5 Examples of Wiring" (page 4-9)



## Series connection

Up to three GL-R units can be serially connected and used as a single light curtain. The series connection is available in all wiring system. The series connection cables that KEYENCE provides as an optional part. (☞ "Series connection cable" (page 1-3))

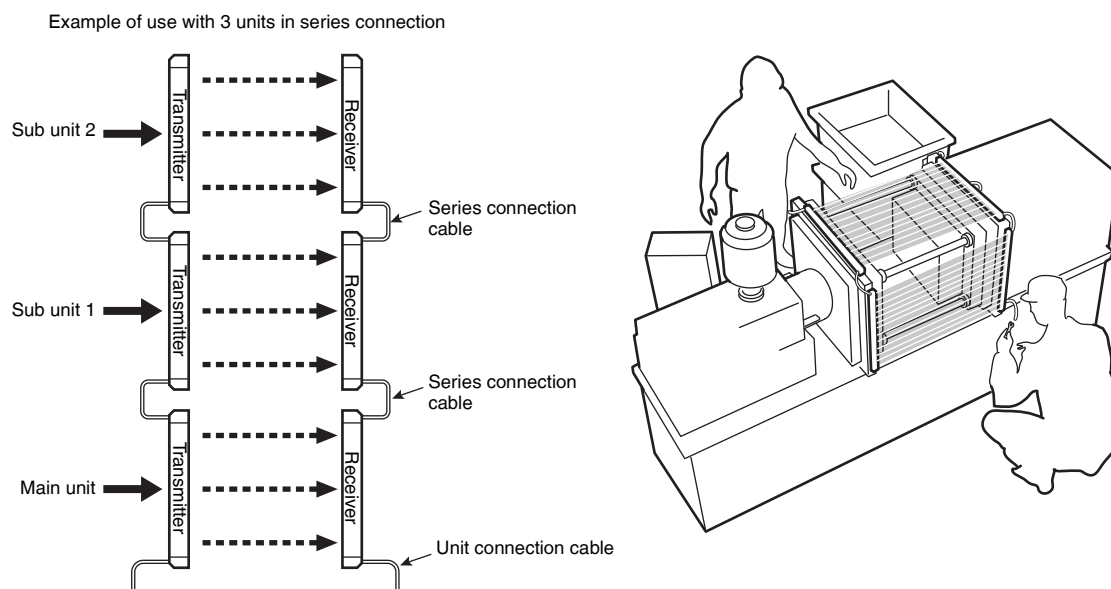

### ■ Benefits

- Prevents light interference between the connected GL-Rs
- Simplified wiring
- Combining the GL-RF, GL-RH and the GL-RL is allowable in series connections even though they have different respective detection capabilities.

### ■ Limitations

- Up to 3 units
- Up to 240 total number of beam axes
- When one-line wiring system is applied, the total length of unit connection cable, extension cable and series connection cables must be 30 m or less.

☞ "1-2 Part Description" (page 1-10)

☞ "4-4 Cable Specification" (page 4-8)



#### Point

**Series connection is required for secure light interference prevention. When not connecting the GL-R units in series, install the units by referring to ☞ "Light Interference Prevention Method" (page 3-8)**

# 2-2 Functions

The wiring system and the type of cable used with the GL-R determine the functions that can be used. Additionally, there are functions that can be activated with or without the configuration software.

Wiring system		Optical synchronization		One-line		Wire synchronization				Page
Cable combination	Cable for the transmitter	5-core		Series connection		7-core		11-core		
	Cable for the receiver	5-core	11-core	5-core	11-core	7-core	11-core	7-core	11-core	
Available function	OSSD output	✓	✓	✓	✓	✓	✓	✓	✓	2-6
	AUX (auxiliary) output		✓		✓	☐	✓	☐	✓	2-37
	Error output		☐		☐	✓	✓	✓	✓	2-37
	Muting function		☐		☐		☐	✓	✓	2-13
	Partial muting function		☐		☐		☐	☐	☐	2-16
	Muting bank function								☐	2-16
	Muted condition output		☐		☐		☐	☐	☐	2-38
	Muting lamp output							✓	✓	2-38
	Override function							✓(☐)	✓(☐)	2-28
	Interlock function		✓(☐)		✓(☐)		✓(☐)		✓(☐)	2-7
	Interlock-reset-ready output		☐		☐		☐		☐	2-40
	EDM function		✓(☐)		✓(☐)		✓(☐)		✓(☐)	2-12
	Wait input					✓	✓	✓	✓	2-34
	Alert output		☐		☐	☐	☐	☐	☐	2-39
	Clear/Block output		☐		☐	☐	☐	☐	☐	2-40
	Reset input (for error)		✓		✓		✓		✓	A-4
	Reduced resolution function	✓(☐)	✓(☐)	✓(☐)	✓(☐)	✓(☐)	✓(☐)	✓(☐)	✓(☐)	2-32
	Fixed blanking function	☐	☐	☐	☐	☐	☐	☐	☐	2-31
Channel configuration (Light interference prevention function)	✓	✓	✓	✓	✓	✓	✓	✓	3-8	
Center indicator configuration	✓(☐)	✓(☐)	✓(☐)	✓(☐)	✓(☐)	✓(☐)	✓(☐)	✓(☐)	5-5	
Monitoring function	☐	☐	☐	☐	☐	☐	☐	☐	6-23	

✓ : Available without the configuration software

☐ : Available with the configuration software

✓(☐) : Available without the configuration software, Functionality can be expanded when using the configuration software.

Requirement	Function	Page
Output a signal when an error occurs.	Error output function	2-37
Output a signal for monitoring by the PLC.	AUX output function	2-37
Inform the external devices of the status of the amount of received light.	Alert output function	2-39
Prevent the OSSD from automatically going to the ON state from an OFF state when all beam axes are cleared.	Interlock function	2-7
Suspend the GL-R's safety functions temporarily while the workpiece is passing through the detection area.	Muting function	2-13
Make sure whether the beam axes are clear or blocked.	Clear / Blocked output function	2-40
Suspend the GL-R's safety functions temporarily in order to activate the machine while the workpiece remains in the detection area.	Override function	2-28
Ignore an object which is smaller than the specified size.	Reduced resolution function	2-32
Ignore an object which is fixed in the detection area.	Fixed blanking function	2-31
Separate the power supplies for the transmitter and receiver which are located far away from each other.	Optical synchronization	2-2
Make sure whether the beam axes are optically aligned.	Monitoring function	6-23

**Availability of functions which can be configured by the configuration software**

📖 "Chapter 6 Setting Method Using the Configuration Software" (page 6-1)

Using certain functions that are configured by the configuration software may limit the availability of other functions because they may share the same wires. The availability of functions is as follows:

✓: Available      -: Not Available

		Function availability								
		Interlock function	Configure the automatica or manual modes via wiring	AUX output function (Non safety-related output)	EDM function	Muting function when optical synchronization or one-line system is applied	Muting bank function	Override function	Wait input function	Built-in indicator function
Functions to be used	Interlock function		✓	✓	✓	*	✓	✓	✓	✓
	Configure the automatica or manual modes via wiring	✓		✓	✓	-	-	✓	✓	✓
	AUX output function (Non safety-related output)	✓	✓		✓	-	✓	✓	✓	✓
	EDM function	✓	✓	✓		*	✓	✓	✓	✓
	Muting function when optical synchronization or one-line system is applied	*	-	-	*		-	-	-	-
	Muting bank function	✓	-	✓	✓	-		-	-	-
	Override function	✓	✓	✓	✓	-	-		✓	-
	Wait input function	✓	✓	✓	✓	-	-	✓		-
	Built-in indicator function	✓	✓	✓	✓	-	-	-	-	

\* Either the interlock or EDM functions is available while the muting function is used when optical synchronization system or one-line system is applied.

## 2-3 OSSD

2

Functions and Features

The OSSD is a safety-related control output. It connects to an external device (load), such as an FSD or MPCE. The GL-R generates self-diagnosis signals on its internal control circuit to perform diagnostics on the output circuit (OSSD). These signals periodically force the OSSD into a temporary OFF state when no interruption exists in the detection zone.

If the internal control circuit receives a feed-back signal (OFF signal) based on the self-diagnosis, the GL-R determines that its output circuit is operating normally. If this OFF signal is not returned to the internal control circuit, the GL-R determines that there is a problem in its output circuit or wiring and goes to the error condition.

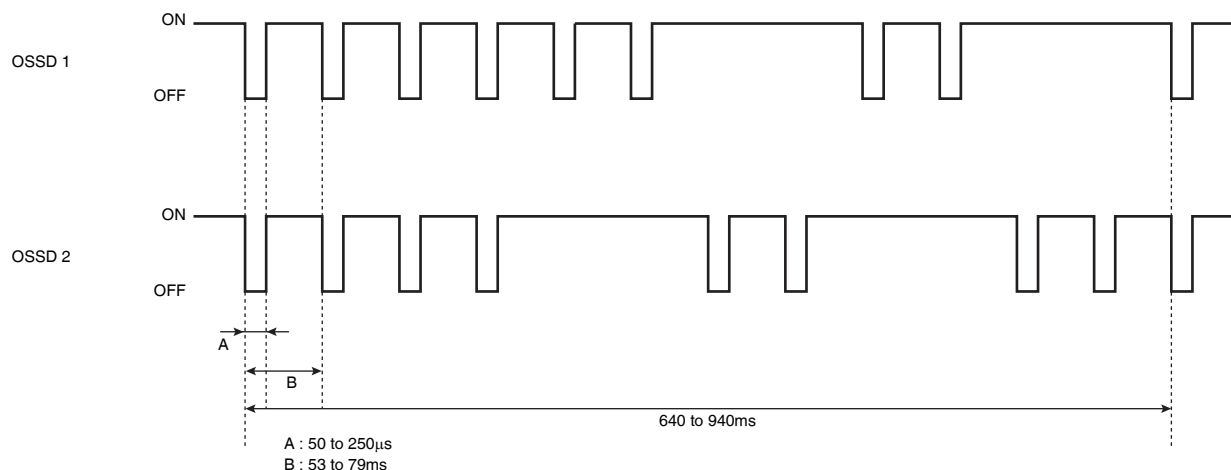

	<p><b>For the wiring between the GL-R and the safety-related part of a machine control system, both OSSD 1 and OSSD 2 must always be wired to a safety-related part of the machine control system in order to ensure safety. If only one OSSD is wired to the safety-related part of a machine control system, it results in significant harm to the machine operators, including serious injury or death, if OSSD malfunction were to occur.</b></p>
---	---

See  "Time chart" (page 2-10) for the case of start-up and all beam axes clear or blocked.

 <b>Point</b>	<p><b>The devices connected to the OSSD, such as safety relay or contactor, should not respond to these temporary, self-diagnostic OFF-signals.</b></p>
--	---

See  "Functions" (page 2-4) for the information of wiring system and cable type to activate this function.

# 2-4 Interlock Function

Interlock is a function that prevents the OSSD from automatically going to the ON state from an OFF state. You can prevent the unintended start-up and/or the unintended restart of the machine if an interlock is applied to the GL-R. You can determine whether this interlock function is enabled at start-up, at restart or both.

Start-up and restart are defined as follows:

**Start-up:**

- When power is supplied after being in an un-powered state.
- When the GL-R is restored from error condition through a reset input.
- When the configuration data is transferred by using the configuration software.

**Restart:**

- After the curtains have been interrupted or misaligned, restart is when the OSSD's go back to the ON state from the OFF state. (Except for a start-up condition)
- Wait input goes to OFF state from ON state when all beam axes are clear.  
📖 "2-9 Wait Input Function" (page 2-34)

	<ul style="list-style-type: none"> <li>• <b>The interlock reset mechanisms (such as switches) must be installed so that the entire hazardous zone can be checked by the responsible personnel and that operation of the interlock reset mechanisms is not possible within the hazardous zone.</b></li> <li>• <b>Be sure to absolutely confirm that there is nobody in the hazardous zone before the interlock is released by the interlock reset mechanism. Failure to follow this warning may result in significant harm to the machine operators including injury or death.</b></li> </ul>
---	--

See 📖 "Functions" (page 2-4) for the information of wiring system and cable type to activate this function.

## Configuration method

The interlock function can be configured through one of the following two methods. The available combination for start and restart interlock differs depending on the configuration method.

● **Configuration via wiring of the interlock selection input**

📖 "Wiring" (page 2-9)

● **Configuration via the configuration software**

📖 "Interlock" (page 6-21)

■ **Available combination for start and restart interlock**

✓: Available      -: Not Available

Start-up / Restart	Configuration via wiring	Configuration via the configuration software
Automatic start / Automatic restart	✓	✓
Manual start / Automatic restart	-	✓
Manual start / Manual restart	✓	✓

\* When using the 5-core cable or 7-core cable, the GL-R automatically operates on "Automatic start / Automatic restart".

## Details of operation mode

### ■ Start-up

- **Automatic start** : **Interlock function is not activated. The GL-R starts operation automatically without a reset input.**

The OSSD goes into the ON-state automatically if the GL-R detects no interruption in the detection zone at start-up. This mode can be used for a machine as long as people can only access the hazardous area by passing through the protection zone of the curtains. Or, Automatic start mode can be used if the safety-related part of a control system other than the GL-R, such as a safety relay unit, can ensure safety by other means.

- **Manual start** : **Interlock function is activated. The GL-R starts operation only after the GL-R receives a reset input.**

The OSSD remains in the OFF-state at start-up (Interlock condition). It is necessary to perform a reset input once the GL-R detects no interruption in the detection zone, in order for the machine to start operation. After the reset input, the OSSD goes into the ON-state, and the interlock condition is terminated. Manual start mode prevents unexpected/unintended start-up of the machine or machinery.

### ■ Restart

- **Automatic restart** : **Interlock function is not activated. The GL-R starts operation automatically without a reset input.**

The OSSD goes into the ON-state automatically at restart if the object detected by the GL-R is removed from the detection zone.

This mode can be used for the machine that nobody can go into or approach the hazardous area with only passing through the protection zone, or can be used if the safety-related part of a control system other than the GL-R, such as safety relay unit, can ensure the safety with other means.

- **Manual restart** : **Interlock function is activated. The GL-R starts operation only after the GL-R receives a reset input.**

The OSSD remains in the OFF-state even after the object detected by the GL-R is removed from the detection zone. (Interlock condition).

It is necessary to perform a reset input once the GL-R detects no interruption in the detection zone, in order for the machine to start operation. After the reset input, the OSSD goes into the ON state, and the interlock condition is terminated.

## Wiring

### ! Point

- The switch for reset input must be rated at 24 V DC, 2 to 3 mA.
- When configuring by using the configuration software, the pink wire is not necessary. If no function is assigned, make the pink wire insulated.

### ■ When the automatic start and automatic restart modes are applied

When using a PNP output type cable

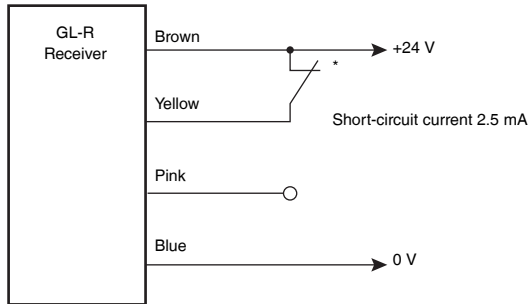

When using an NPN output type cable

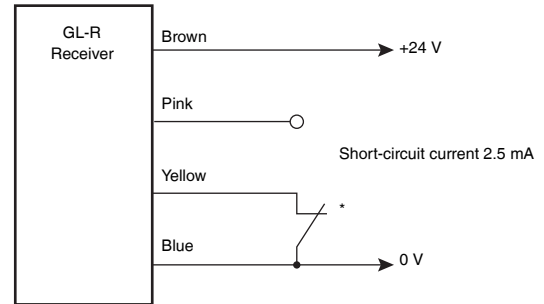

- \* A reset switch to remove an error. If you do not need to remove an error, the yellow wire must be directly connected to the brown (blue) wire when using a PNP (NPN) output type cable.

📖 "In case where the GL-R goes back to the normal operation with reset operation" (page A-3)

### ■ When the manual start or manual restart modes are applied

When using a PNP output type cable

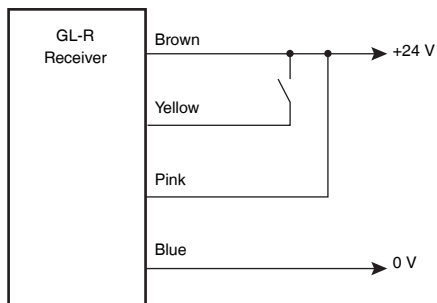

When using an NPN output type cable

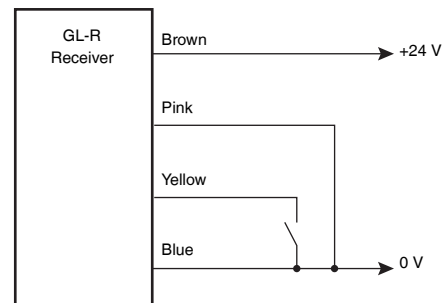

Time chart

■ Automatic start / Automatic restart

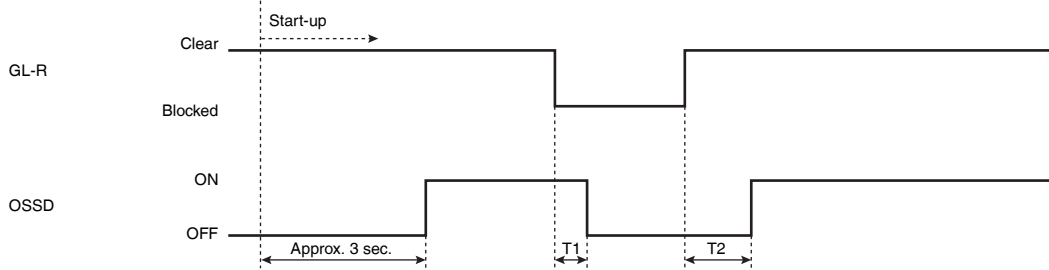

T1: ON to OFF Response time "Response time (OSSD)" (page 7-5)

T2: OFF to ON Response time "Response time (OSSD)" (page 7-5)

■ Manual start / Automatic restart

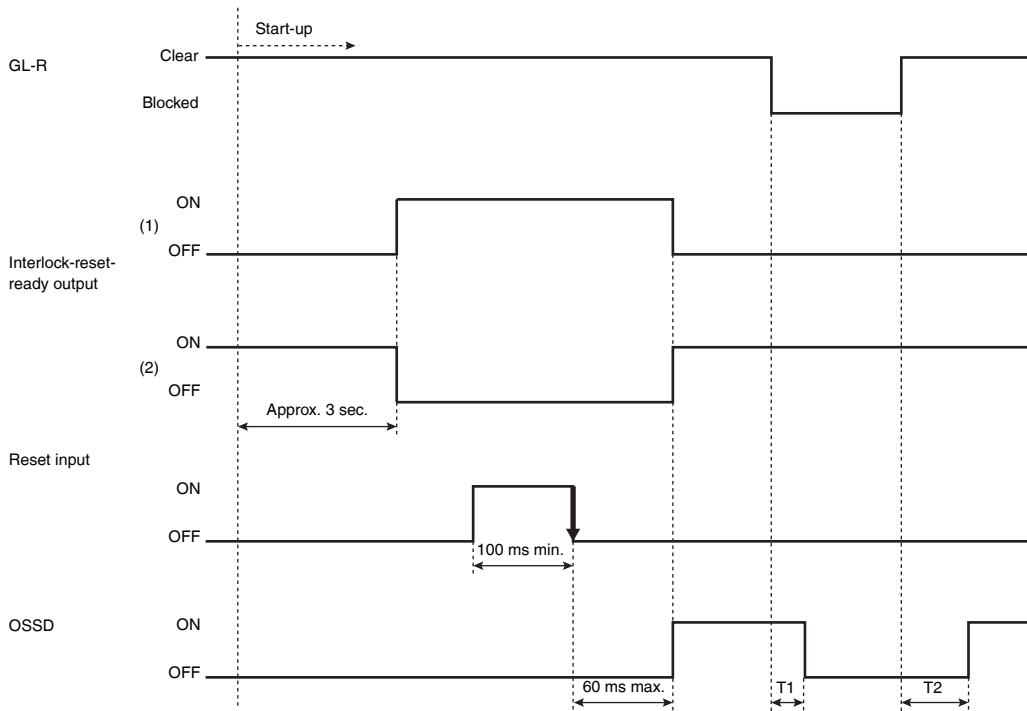

T1: ON to OFF Response time "Response time (OSSD)" (page 7-5)

T2: OFF to ON Response time "Response time (OSSD)" (page 7-5)

- (1) When using a PNP output cable to connect to a PNP input device, or when using an NPN output cable to connect to an NPN input device
- (2) When using a PNP output cable to connect to an NPN input device, or when using an NPN output cable to connect to a PNP input device

Reference

You can make sure whether the GL-R is ready to reset the interlock condition by the external device connected to the interlock-reset-ready output.

"Non Safety-Related Outputs" (page 2-36)



## Manual start / Manual restart

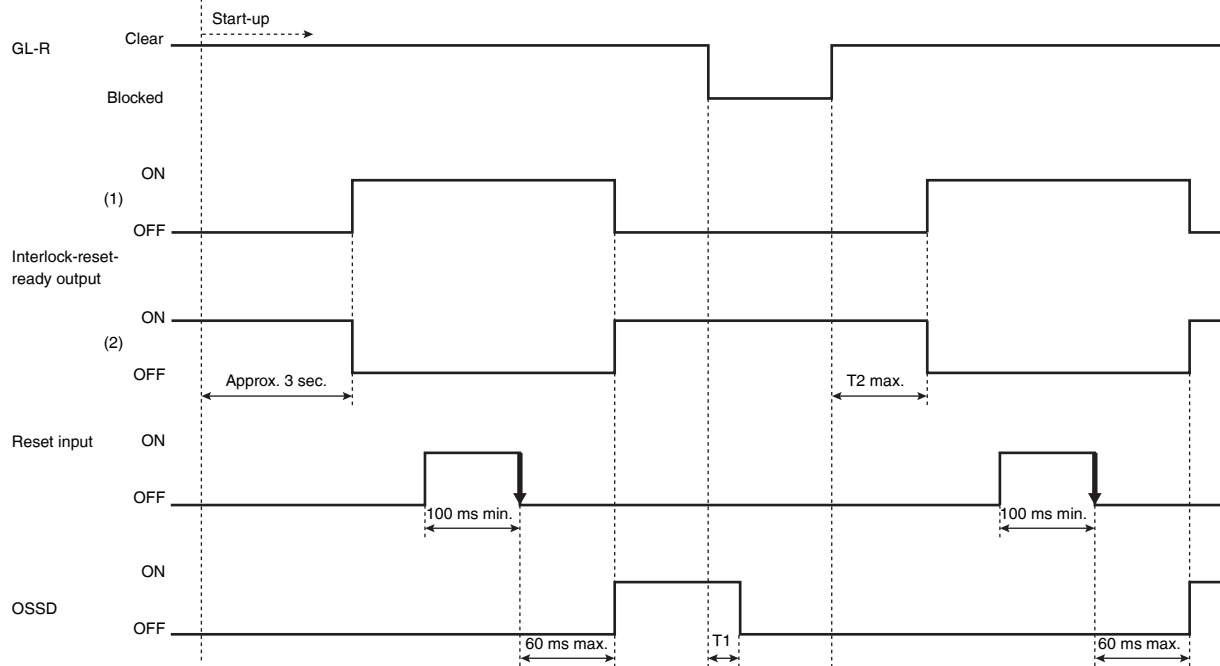

T1: ON to OFF Response time "Response time (OSSD)" (page 7-5)

T2 : OFF to ON Response time "Response time (OSSD)" (page 7-5)

- (1) When using a PNP output cable to connect to a PNP input device, or when using an NPN output cable to connect to an NPN input device
- (2) When using a PNP output cable to connect to an NPN input device, or when using an NPN output cable to connect to a PNP input device

### Reference

You can make sure whether the GL-R is ready to reset the interlock condition by the external device connected to the interlock-reset-ready output.

"Non Safety-Related Outputs" (page 2-36)

EDM (External Device Monitoring) is a function of the GL-R that monitors the state of the control devices which are externally connected to the GL-R. The GL-R can detect a fault, such as welded contacts on external devices, as long as the EDM function is activated.

See "Functions" (page 2-4) for the information of wiring system and cable type to activate this function.

### Wiring

When using a PNP output type cable

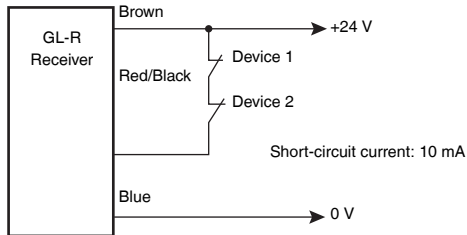

When using an NPN output type cable

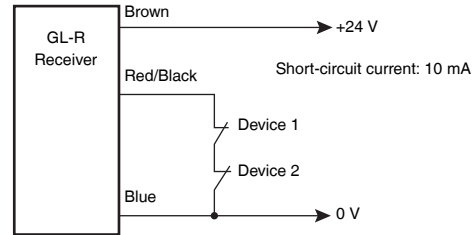

**Reference**

using the 11-core cable and not using the EDM function, short-circuit the EDM input and AUX output (Red wire on the receiver) or do not apply the EDM function through the configuration software.

"4-5 Examples of Wiring" (page 4-9)

"EDM" (page 6-21)

### Time chart

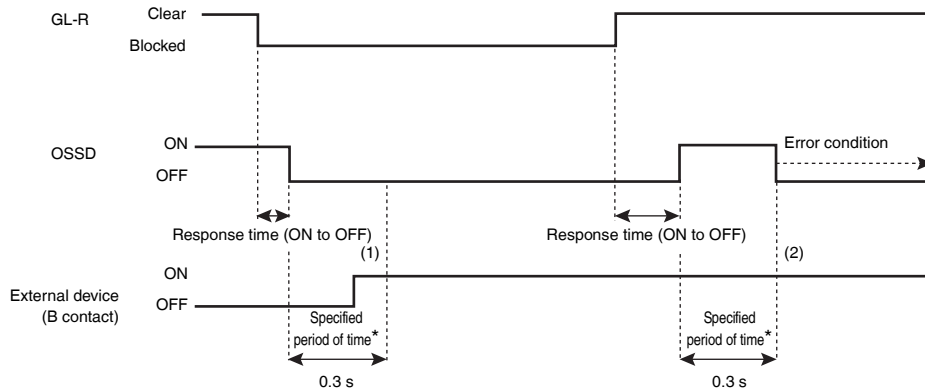

- (1) If the GL-R detects the operation of the external devices within the specified period of time (0.3 s) after the operation of OSSD (ON to OFF, or OFF to ON), the GL-R continues normal operation.
- (2) Unless the GL-R detects the operation of an external device within the specified period of time (0.3 s)\* after the operation of OSSD (ON to OFF, OFF to ON), the GL-R goes into an error condition due to an EDM error.

\* Period of time can be configured through the configuration software. "EDM" (page 6-21)

## Muting function

The muting function is used to temporarily suspend the GL-R's safety functions while the GL-R system meet the specified condition for muting. Before this function can be used, the outputs from the muting devices must be connected to the muting input terminal on the GL-R.



In addition, the configuration software provides the user with the opportunity to select the beam axes to be in the muted condition.

You can minimize the number of beam axes to be in the muted condition through the configuration software (Partial muting function). Therefore, you can reduce the risk of interrupting the hazardous zone. You can set three separate muting banks and select among these groups through the external input (Muting bank function).

See  "Functions" (page 2-4) for the information of wiring system and cable type to activate this function.

- There is no limitation to configure this function.

### Point

- When optical synchronization system or one-line system is applied, select "Apply Muting input to receiver" through the configuration software.  "(1) Muting" (page 6-17)
- For more specific examples of operations or for information about installation when using the muting function.  "Example: Muting function with 2 muting devices (Sensors)" (page 2-18)

### DANGER

- Since the muting function temporarily suspends the safety functions of the GL-R, additional safety measures are required for the entire machine on which the GL-R is installed. This is to ensure safety while the muting function is activated.
- The muting devices, the installation of those devices and the procedure to activate the muting function must fulfill the conditions specified in this user's manual and the requirements of the laws, rules, regulations, and standards in the country or region in which the GL-R and those devices are used. Failure to follow this warning may result in significant harm to the machine operators, including serious injury or death.
- When you install the muting devices (such as sensors or switches), the following conditions must be fulfilled.
  - (1) Muting devices must be installed so that the muting function cannot be activated if the machine that the GL-R is on is in the middle of a hazardous cycle or period.
  - (2) Muting devices must be installed so that the muting function cannot be activated by personnel approaching the detection zone of the GL-R.
- Only responsible personnel should be allowed to install or wire the muting function or muting devices.
- The muting devices must be installed in such a way that only responsible personnel can change the installation or orientation by requiring special tools or keys to access the devices.
- The whole responsibility for use of the muting function must rest with the customer. Those who use the muting function must fulfill all of the requirements related to muting functions. KEYENCE accepts NO responsibility or liability for any damage or injury due to unauthorized installation, unauthorized usage or maintenance methods that are not specified in this user's manual and/or due to noncompliance with the laws, rules, regulations and standards set fourth by the country or region in which the GL-R is used.
- The installation of a muting lamp may be required by the laws, rules, regulations, and standards in the country or region in which the GL-R is used if you apply the muting function. It depends on the machine application and/or the result of your risk assessment. If it is necessary for you to provide the muting lamp, you must fulfill the requirements because you are fully responsible for installation of the muting lamp.
- Those who intend to use the option related to the conditions for muting (page 2-38) must perform the risk assessment based on their machine application.

## Devices used for muting function

### ■ Muting device

- The muting device output must be N.O. (normally open).
- A PNP output muting device is required when using the PNP output type cable and an NPN output muting device is required when using the NPN output type cable. The muting device must be capable of 2 to 3 mA current.
- Do not use one muting device with multiple outputs in place of two or more muting devices. (Only one output per one muting device must be used.)
- If the muting device has a timer function that can adjust the output timing, do not use that function.

### ■ Muting lamp

When using the muting lamp, it must meet the following conditions.

For an incandescent lamp : rated 24 V DC, 1 to 5.5 W

For an LED indicator : rated current consumption must be 10 to 230 mA.

The GL-R can be configured to go to an error condition if the muting lamp does not meet the above conditions, for example, the lamp is broken.

📖 "Muting" (page 6-17)

## Detailed operation

### ■ Conditions for initiation of muting

Muted condition is initiated if all of the following conditions are met:

- Muting input 2 turns ON within 0.04 to 3 seconds after muting input 1 turns ON\*
- GL-R detects no interruption in the detection zone
- OSSD is in the ON state and remains for 0.5 seconds or more.

### ■ Conditions for termination of muting

Muted condition is terminated if one of the following conditions is met.

- Either of the muting inputs goes to the OFF state for at least 5 ms.
- Light curtain goes to an error condition
- Wait input goes to ON state
- The power supply is interrupted or restored.
- Maximum muting period of approx. 5 minutes has been passed.\*
- When partial muting function is applied, an axis which is not muted is blocked.

\* The parameter can be changed through the configuration software. 📖 "Muting" (page 6-17)

#### Reference

When the GL-R is interrupted, the GL-R cannot go to the muted condition. In this case, you can apply override function to suspend the safety functions temporarily. 📖 "Override function" (page 2-28)

## Time chart

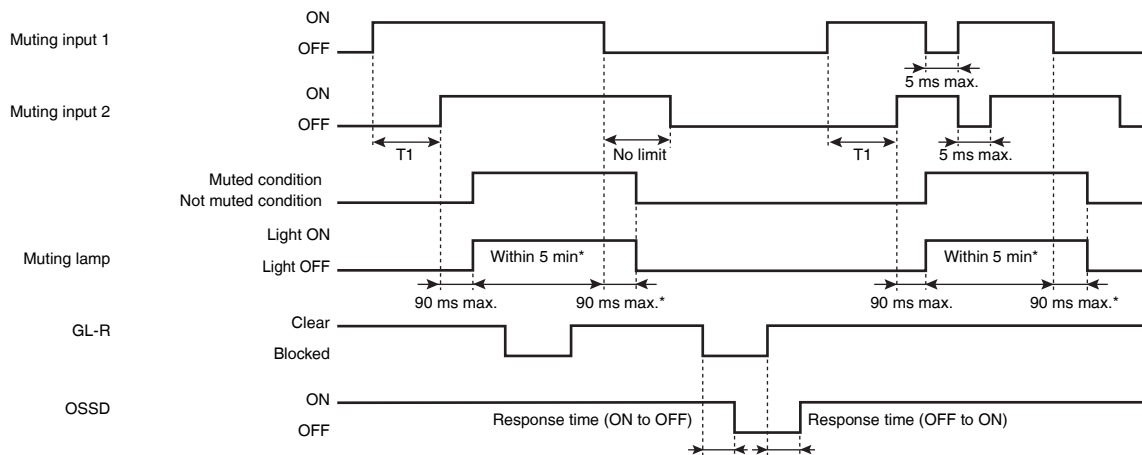

T1: 0.04 to 3 seconds\*

\* Parameters can be configured through the configuration software. "Muting" (page 6-17)

### ! Point

- If muting input 2 turns on outside the T1 range after muting input 1 turns on, the GL-R will not mute and remains in normal operation. (The GL-R does not go into an error condition or interlock condition.)
- If only muting input 1 or muting input 2 turn OFF and back ON, the GL-R will not return to the muted condition. To return to the muted condition, both muting inputs 1 and 2 must first turn OFF and the muting conditions must be met again.
- If the GL-R power is turned ON while the GL-R is in the muted condition or either muting input 1 or 2 is on, the GL-R will not go to a muted condition. In this case, both muting inputs must be turned OFF and the muting conditions must be met again.

### Reference

- The function indicators and 7-segment display indicate each condition. "Function Indicators and 7-segment Display" (page 5-2)
- If the GL-R does not go to muted condition when both muting input 1 and 2 are ON, all muting condition are not met. The configuration software can show the conditions which are not met. "I/O monitoring" (page 6-24)

**Partial muting function / Muting bank function**

The partial muting function and muting bank function can be activated through the configuration software.

☐ "Muting" (page 6-17)

For more information about the combination of the wiring system and cables to apply these functions, see

☐ "2-2 Functions" (page 2-4).

■ **Partial muting function**

You can select which beam axes will go into a muted condition upon the activation of muting.

■ **Muting bank function**

You can configure up to three muting banks on the GL-R. Each muting bank is a group of beam axes that will go into a muted state upon activation of muting. In order to activate a muting bank, you must switch (ON and OFF) the muting bank input.

	Muting bank input 1 (White wire on the transmitter)	Muting bank input 2 (Yellow wire on the transmitter)	Muting bank input 3 (Pink wire on the receiver)
Muting bank 1 active	ON	ON	ON
Muting bank 2 active	OFF	OFF	ON
Muting bank 3 active	ON	OFF	OFF

**! Point** The muting function is not activated if the combination of muting bank inputs are out of above table.

● **Time Chart for the Muting Bank Function**

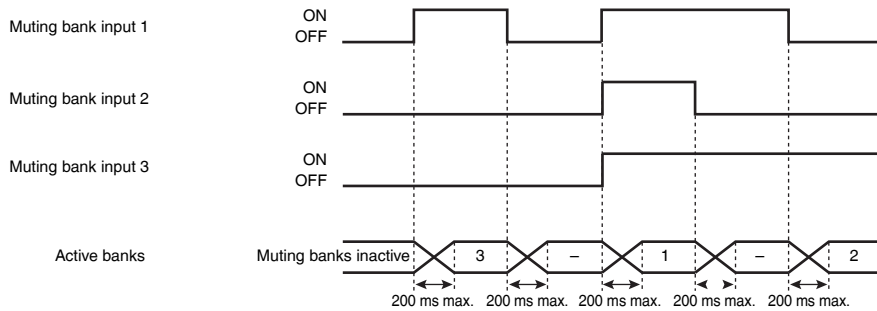

**Reference** The GL-R does not go to the normal condition if the muting bank inputs are changed while the GL-R is in the muted condition.

● **Wiring**

When using a PNP output type cable

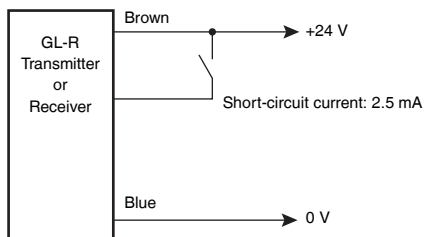

When using an NPN output type cable

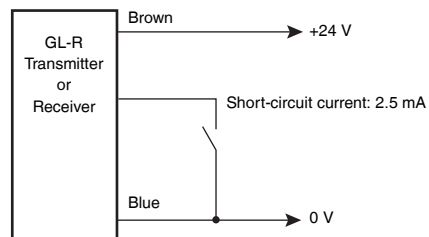

See ☐ "When "Apply muting bank" is selected." (page 4-7) for the color of wire.

## Changing configuration of the muting function

The conditions related to muting can be changed through the configuration software.

📖 "Muting" (page 6-17)

	Item	Option
Changing of the conditions for initiation of muting	(1) Time period specification of muting inputs. Time period specification of 0.04 s to 3 s between muting input 1 and muting input 2 can be changed. The lower limit of 0.04 s cannot be changed.	1 second
		3 seconds (default)
10 seconds		
30 seconds		
Not specified		
	(2) Sequence specification of muting inputs. Sequence specification of muting inputs can be changed. (Default sequence: muting input 1 is first, muting input 2 is second.)	1→2 fixed (default)
		Not specified
Conditions for termination of muting	(3) Muting OFF delay time. Time period specification from muting input OFF to termination of muted condition.	0 seconds (default)
		4 seconds
	(4) Maximum muting period. Maximum muting period of approx. 5 minutes can be changed.	1 minute
		5 minutes (default)
		10 minutes
		20 minutes
(5) Muting lamp error Sets whether the GL-R goes into the error condition when there is a muting lamp error.	Only warning (default)	
	Error	
(6) Muting area configuration		–
(7) Muting bank function		Not apply (default)
		Apply
(8) Assignment of the muting input to the wire on the receiver		Do not assign (default)
		Assign

 <b>DANGER</b>	<b>Users who intend to use the options mentioned above from (1) to (4), (6) and (7) have to perform the risk assessment based on their machine application.</b>
---	---

<b>NOTICE</b>	<p><b>When "Not specified" is selected for time between muting inputs, perform the risk assessment in case for the malfunction of muting devices and be sure to the following:</b></p> <ul style="list-style-type: none"> <li><b>Muted condition is terminated approx. 5 minutes later when the time between muting inputs exceeds 3 seconds, if the setting is longer than 3 seconds.</b> <b>(If the time between muting inputs does not exceed 3 seconds, the muted condition continues.)</b></li> </ul>
---------------	--

**Example: Muting function with 2 muting devices (Sensors)**

The following is an example of the muted condition while the workpiece is passing through the detection area of the GL-R. In this example, 2 retro-reflective photoelectric sensors are used as the muting devices (ON when the beam from the sensor is blocked).

■ **Conditions for installation of muting devices**

All 4 of the following conditions must be met in order to ensure a continuous muted condition while the workpiece is passing through the detection area.

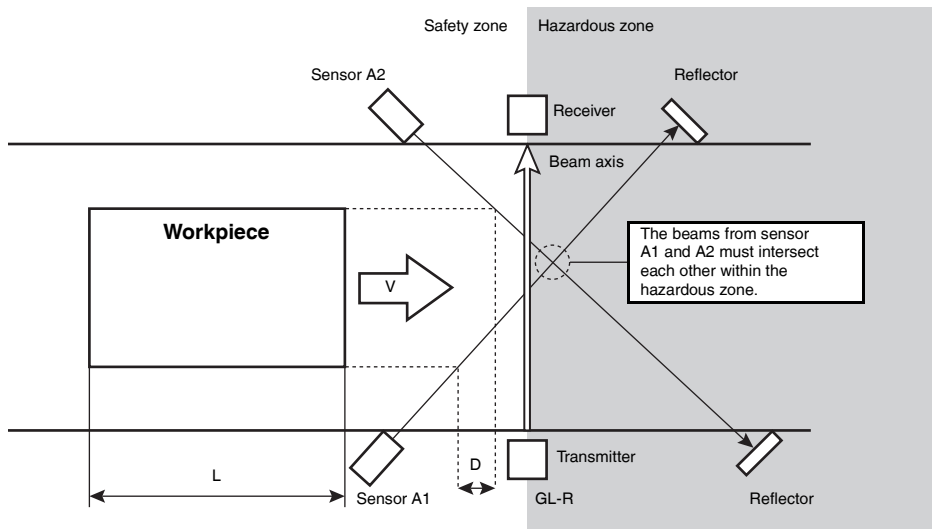

$L$  (mm) : Length of the workpiece

$D$  (mm) : Displacement distance between the point where the workpiece first interrupts each beam.

$V$  (mm/s) : Workpiece speed

The activation time of muting input 1 and that of muting input 2 must be between 0.04 to 3 seconds.

(1)  $0.04 < D / V < 3$

(2)  $D < L$

(3) Both sensor A1 and sensor A2 must be installed so that their beams intersect in the hazardous area.

(4) Both sensor A1 and sensor A2 must turn ON when the beam is blocked (Dark ON).



## ■ Explanation

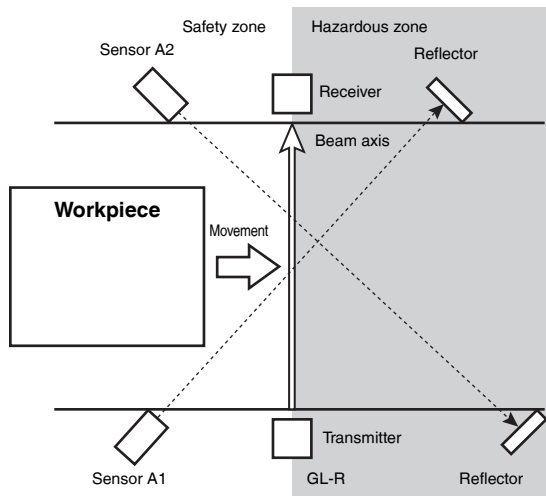

- (1) The workpiece is approaching the detection zone but the GL-R does not go into the muted condition because both muting input 1 and 2 are OFF. At this point, the GL-R continues normal operation and OSSD goes OFF if the GL-R gets interrupted.

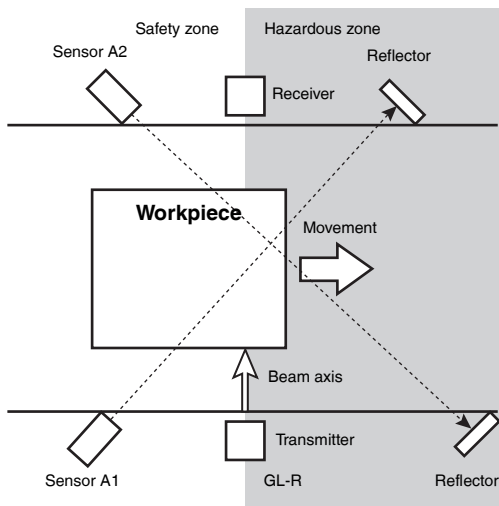

- (2) The workpiece interrupts the beam from sensor A1 first, and then interrupts the beam from sensor A2. The GL-R then goes into the muted condition and the OSSD does not turn off even if the GL-R detects an interruption.

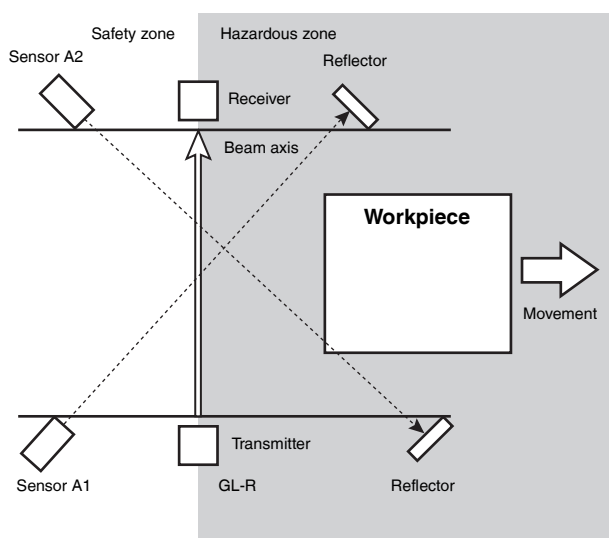

- (3) The GL-R goes back to normal operation (not muted) if either sensor A1 or sensor A2 turns off as the workpiece passes.

■ Wiring the muting inputs

When using the PNP output cable

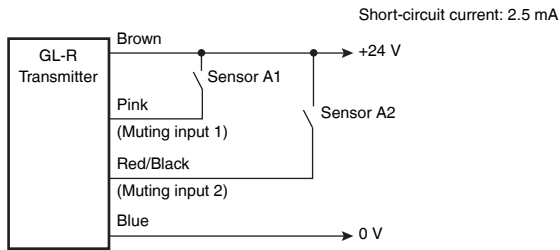

When using the NPN output cable

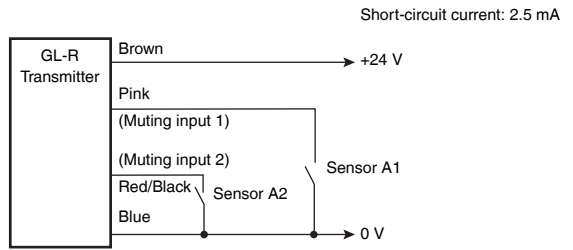

! Point

Output type of the switch or sensor used as the muting device must be the same as the cable used.

Example: PNP output if PNP cable is used, or NPN output if NPN cable is used. Also, the muting device must be able to handle a 3 mA current load.

■ Time chart

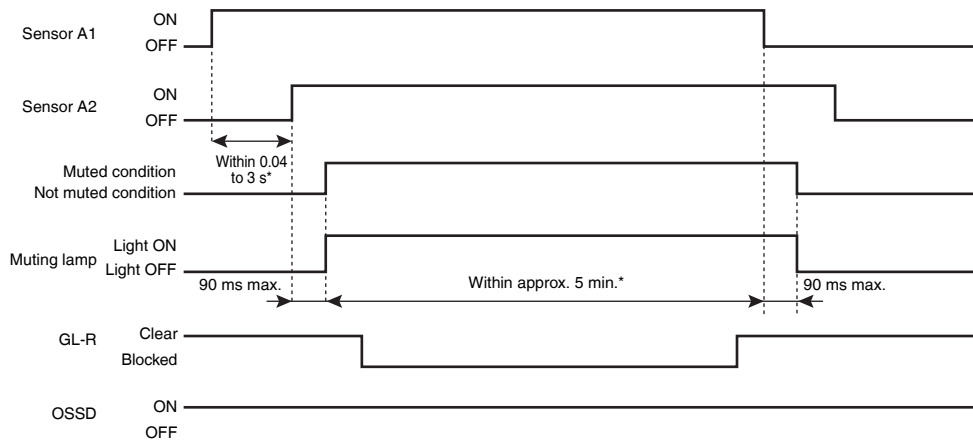

\* Parameters can be configured through the configuration software. □ "Changing configuration of the muting function" (page 2-17)

## Example: Muting function with 4 muting devices

The following is an example of the muted condition while the workpiece is passing through the detection area of the GL-R. In this example, 4 thru-beam photoelectric sensors are used as the muting devices (ON when the beam is blocked).

### ■ Setup conditions

All 4 of the following conditions must be met in order to ensure the continuous muted condition while the workpiece is passing through the detection area.

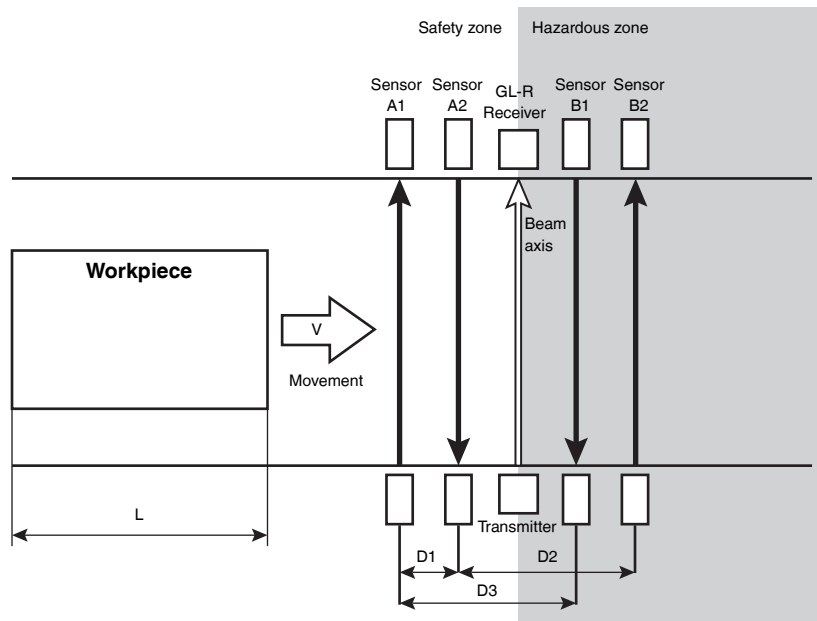

$L$  (mm) : Length of the workpiece

$D1, D2, D3$  (mm) : The spacing between sensors

$V$  (mm/s) : Workpiece speed

The activation time of muting input 1 and that of muting input 2 must be between 0.04 to 3 seconds.

$$(1) 0.04 < D1 / V < 3$$

$$(2) D2 < L$$

$$(3) D3 < L$$

(4) All of sensors A1, A2, B1 and B2 must turn ON when the beam is blocked (Dark ON).

■ Explanation

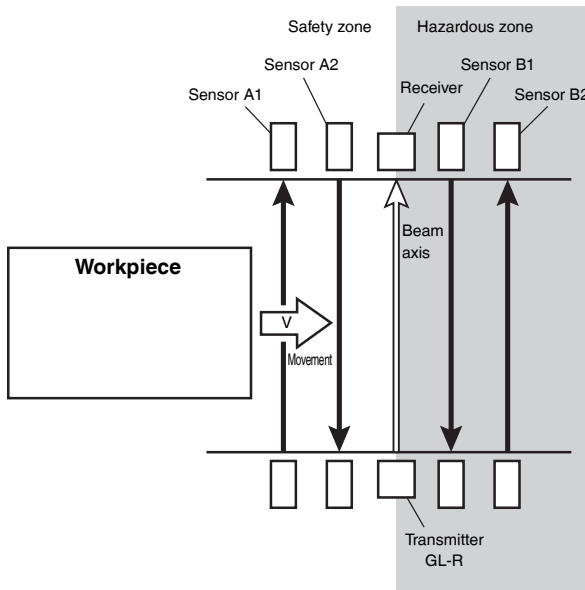

(1) The workpiece is approaching the detection zone but the GL-R does not go into the muted condition because all of the sensors are OFF. At this point, the GL-R continues normal operation and the OSSD goes OFF if the GL-R gets interrupted.

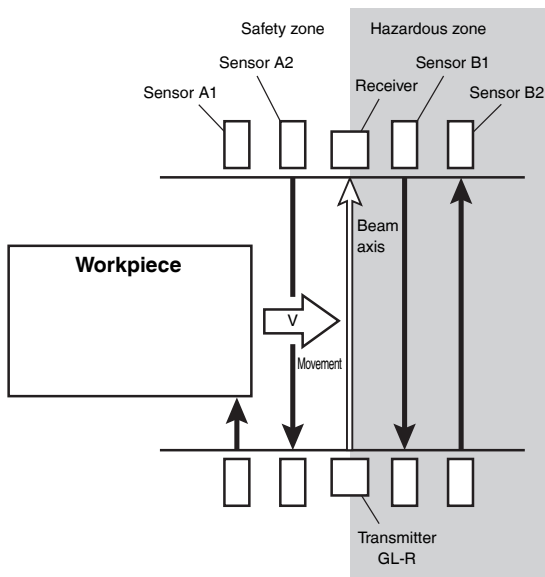

(2) The workpiece interrupts the beam of sensor A1, and turns ON the output. However, the GL-R still continues normal operation.

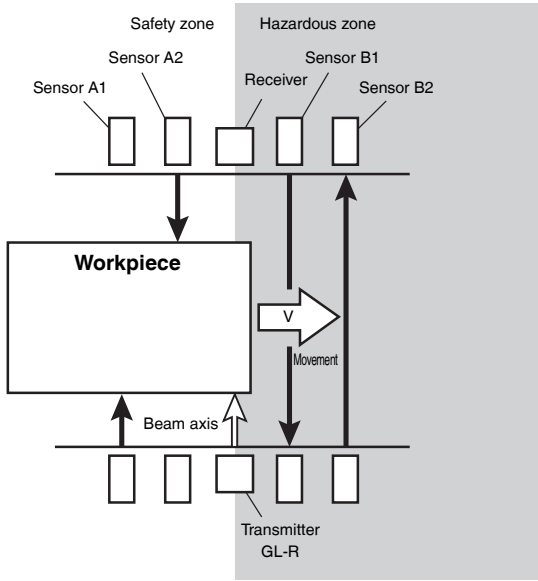

(3) The workpiece interrupts the beam of sensor A1 first, and then interrupts the beam of A2. Then, the GL-R goes into the muted condition and the OSSD does not turn off even if the GL-R detects an interruption.

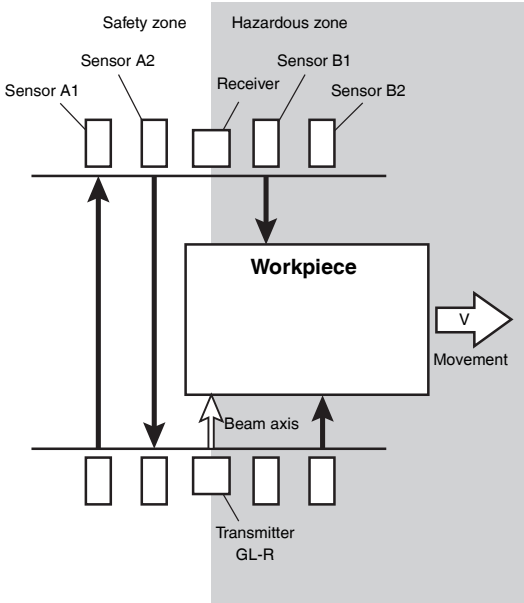

(4) The workpiece is passing through the detection area of the GL-R. The GL-R still continues the muted condition.

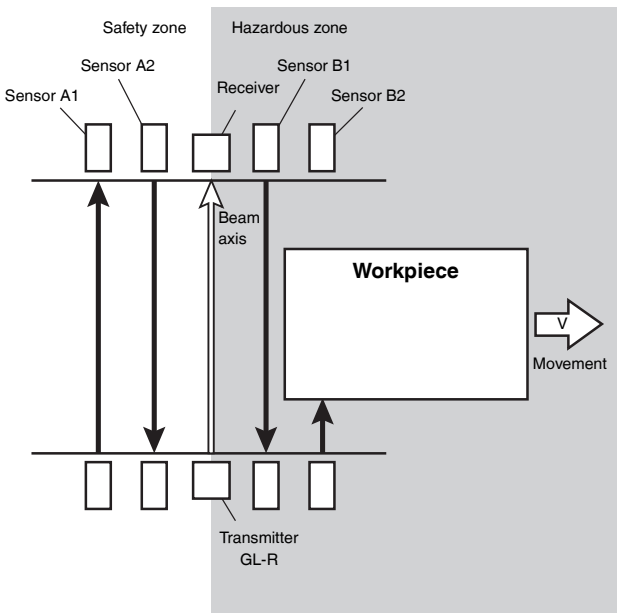

(5) The GL-R goes back to normal operation (not muted) when sensor B1 turns off after the workpiece has been passed.

■ Wiring the muting inputs

When using the PNP output cable

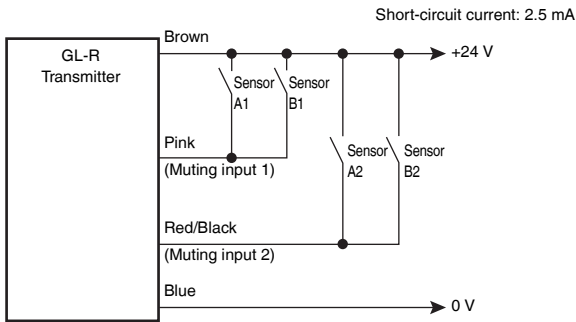

When using the NPN output cable

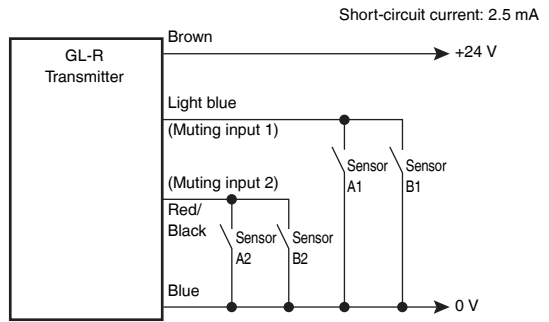

! Point

The output type of the switch or sensor used as the muting device must be the same as the cable used.

Example: PNP output if PNP cable is used, or NPN output if NPN cable is used.

Also, the muting device must be able to handle a 3 mA current load.

■ Time chart

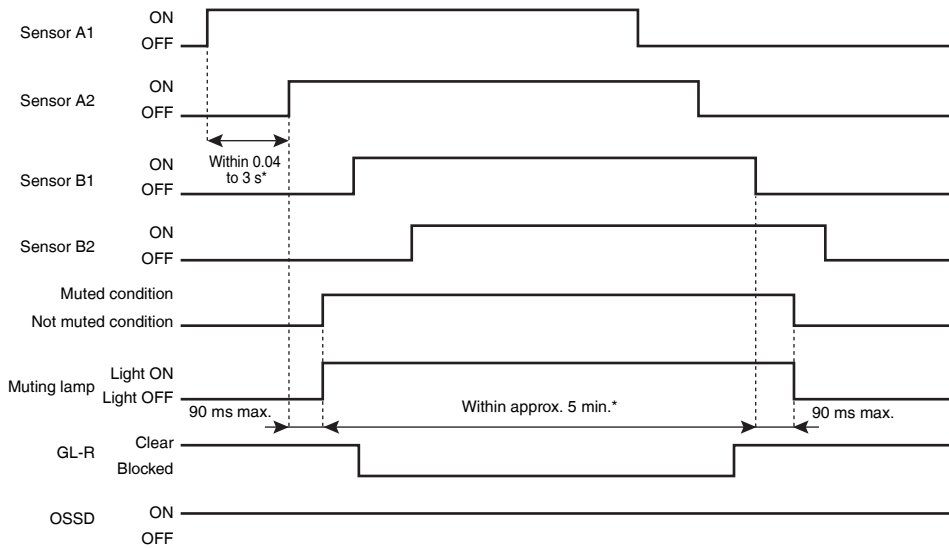

\* Parameters can be configured through the configuration software. □ "Changing configuration of the muting function" (page 2-17)

## Example: Muting function with 2 muting devices (Switches)

The following is an example of the muted condition while the mold is going upward or at the top dead center of the operation. In this example, 2 switches are used as the muting devices.

	<p>The GL-R has not undergone the model certification examination in accordance with Article 44-2 of the Japanese Industrial Safety and Health Law. The GL-R, therefore, cannot be used in Japan as a "Safety Device for Press and Shearing machines" as established in Article 42 of that law.</p>
---	---

### ■ Setup conditions

All 4 of the following conditions must be met in order to ensure the continuous muted condition while the mold is going upward or at the top dead center.

Switches A1 and A2  
must be N.O.

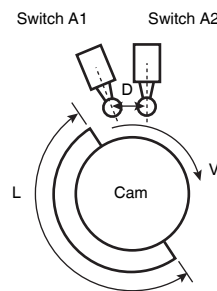

L (mm) : The length of a part of cam that switch can be ON

D (mm) : The spacing between switches

V (mm/s) : Cam speed

The activation time of muting input 1 and muting input 2 must be between 0.04 to 3 seconds.

(1)  $0.04 < D / V < 3$

(2)  $D < L$

(3) Both switch A1 and switch A2 must be ON only while the mold is going upward or at top dead center.

(4) The total time the mold is going upward and the time while it is at the top dead center must be 5 minutes or less.

■ Explanation

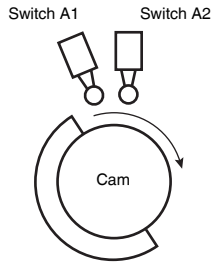

- (1) The GL-R is not muted when the mold is at or stays at the bottom dead center of the press cycle. At this point, the GL-R continues normal operation and the OSSD goes OFF if the GL-R gets interrupted.

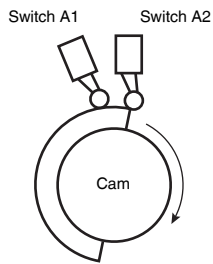

- (2) When switch A1 turns ON first, and then switch A2 turns ON, the GL-R goes into the muted condition and the OSSD does not turn OFF, even if the GL-R detects an interruption.

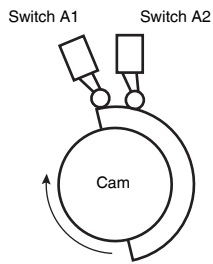

- (3) The GL-R continues the muted condition because both switches stay turned ON and the mold continues to stay at the top dead center position.

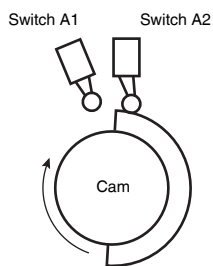

- (4) The GL-R will go back to normal operation (not muted) as soon as sensor A1 turns OFF after the mold starts downward.

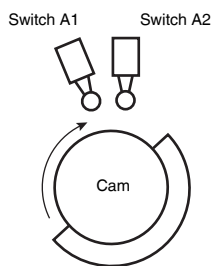

- (5) The GL-R continues normal operation while the mold is going downward.



■ Wiring the muting inputs

When using the PNP output cable

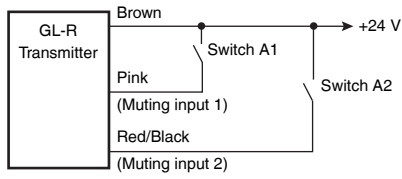

When using the NPN output cable

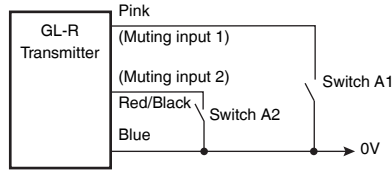

! Point

The output type of the switch or sensor used as the muting device must be the same as the cable used.

Example: PNP output if PNP cable is used, or NPN output if NPN cable is used. Also, the muting device must be able to handle a 3 mA current load.

■ Time chart

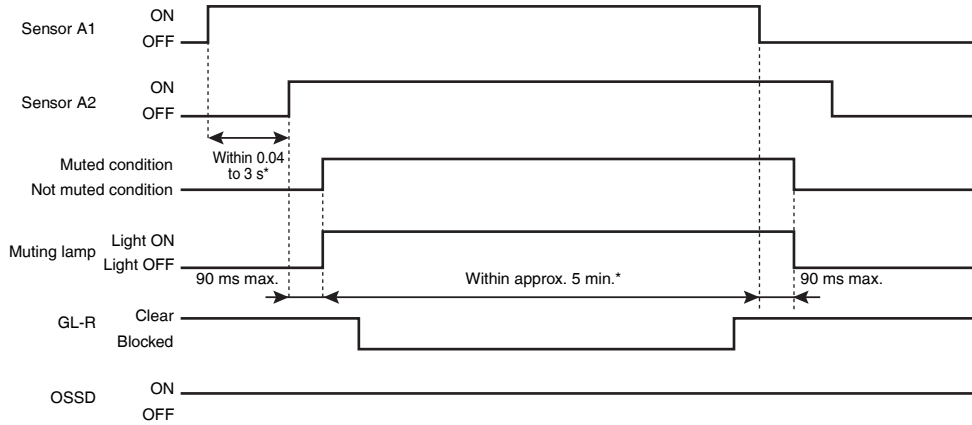

\* Parameters can be configured through the configuration software. □ "Changing configuration of the muting function" (page 2-17)

## Override function

During normal operation, the OSSD goes to an OFF state if the muting function is deactivated and an interruption remains in the detection zone of the GL-R. The OSSD OFF state will remain until the obstruction is removed.

The Override Function allows a temporary manual suspension of the GL-R safety functions. This makes it possible to remove the obstruction remaining in the detection zone of the GL-R. (Machine is able to be manually operated on a temporary basis because the safety function of the GL-R is temporarily suspended.)

See  "Functions" (page 2-4) for the information of wiring system and cable type to activate this function.

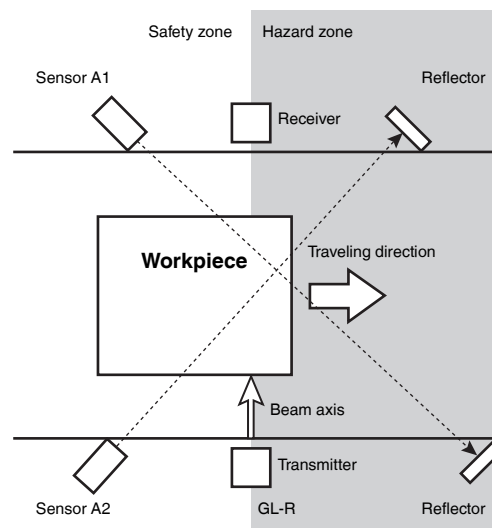

- The override function allows a temporary manual suspension of the GL-R safety functions. Thus, in order to ensure safety while the override function is activated, additional safety measures are required for the entire machine system on which the GL-R is installed.
- The devices, the installation of those devices, and the procedures to activate the override function must fulfill the conditions specified in this user's manual as well as the requirements of the laws, rules, regulations, and standards in the country or region in which the GL-R and those devices are used. Failure to follow this warning may result in significant harm to the machine operators, including serious injury or death.
- The override function allows a temporary manual suspension of the GL-R safety functions. Manual operation devices are required to activate the override function. When installing the devices to activate the override function, the devices must be installed so that the whole hazardous zone can be checked by responsible personnel and that the device operators are not in the hazardous zone.
- Be sure to confirm that there is nobody in the hazardous zone, before the override is activated. Failure to follow this warning may result in significant harm to the machine operators, including serious injury or death.

	<ul style="list-style-type: none"> <li>• The installation of the indication for override may be required by the laws, rules, regulations, and standards in the country or region in which the GL-R is used if you apply the override function. It depends on the machine application and/or the result of your risk assessment. If it is necessary for you to provide the indication for override, you must fulfill the requirements because you are fully responsible for installation of the indication for override.</li> <li>• Only the responsible personnel must be allowed use or activation of the override function.</li> <li>• Those who use the override function must fulfill all requirements related to the override function. KEYENCE accepts NO responsibility and NO liability for any damage or any injury due to the unauthorized installation, usage, or maintenance, which are not specified in this user's manual, and/or due to noncompliance with the laws, rules, regulations and standards in the country or region in which the GL-R is used.</li> </ul>
---	---

### ■ Conditions for initiation of override

The override condition is initiated if all of the following conditions are met and the wait input goes to the ON state within 0.04 to 1 s after the override input turns ON.

- The GL-R is not an error condition.
- OSSD is in the OFF state (including interlock condition).
- GL-R detects interruption in the detection zone. (One or more beam axis is blocked.)
- Either of muting inputs, or both, turns ON state.

### ■ Conditions for termination of override

The override condition is terminated if one of the following conditions is met.

- All of muting inputs turn OFF
- Either the override input or wait input, or both, turn OFF.
- GL-R goes into the error condition.
- Maximum override period of approx. 60 seconds\* has been passed.

\* This can be changed through the configuration software.

### ■ Time chart

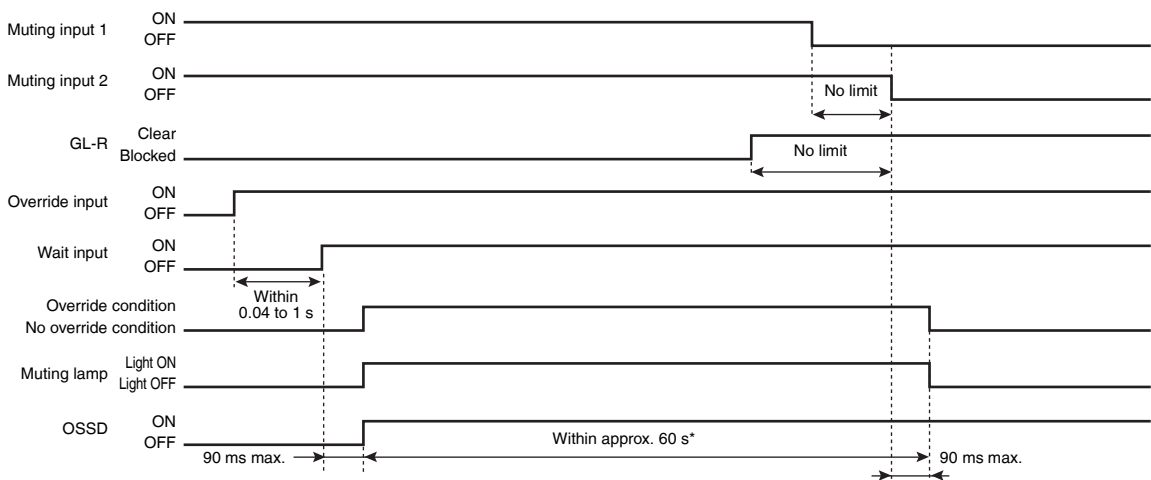

\* The parameter can be configured through the configuration software.  "(3) Override configuration" (page 6-18)

## Override Function Settings

The "Maximum override period" can be changed through the configuration software.

Item	option
Maximum override period	30 second, 1 minute (default), 5 minutes, 15 minutes

See  "(3) Override configuration" (page 6-18).

# 2-7 Fixed Blanking

This function is only enabled through the configuration software. During normal operation, the OSSD remains in the ON state while the GL-R detects no interruption in the detection zone, and the OSSD goes to the OFF state when the GL-R detects interruption in the detection zone. On the other hand, if fixed blanking is enabled on certain beam axes, the OSSD remains in the ON state as long as the GL-R detects interruption on those beam axes and no interruption elsewhere in the detection zone. Additionally, the OSSD goes to the OFF state when the GL-R detects no interruption on any of the blanked beam axes or interruption in the detection zone somewhere other than the blanked beam axes.

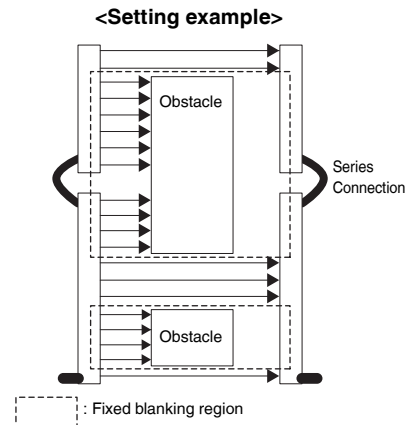

	<p>As shown in the figure to the right, when the fixed blanking function is applied, a hazardous clearance that is not protected by the GL-R may be generated between the obstacle and the GL-R. You must install an additional safety measure such as a safeguard for this clearance.</p>	
--	--	--

**! Point**

- The fixed blanking function can be configured to any of the beam axes, including when the GL-R is in series connection.
- When the GL-R operates in optical synchronization system, the fixed blanking function cannot be configured to both the top and bottom beam axes on the main unit.
  - ☐ "Wiring System" (page 2-2)
- The 7-segment display indicates "F" when the fixed blanking function is applied.
  - ☐ "Function Indicators and 7-segment Display" (page 5-2)

See ☐ "Functions" (page 2-4) for the information of wiring system and cable type to activate this function.

## ■ Procedure for Configuration

See ☐ "Blanking" (page 6-19)

# 2-8 Reduced Resolution

The reduced resolution function can prevent the OSSD from going to the OFF state when the beam axes are blocked by moving object in the protection zone.

During normal operation, the OSSD goes to the OFF state when the GL-R detects interruption in the detection zone.

On the other hand, if reduced resolution is enabled on the GL-R with the number of beam axes to be ignored and not monitored specified, the OSSD remains in the ON state even while the GL-R detects interruption on certain beam axes, as long as the total number of interrupted beam axes is less than or equal to the number of ignored beams.

	<p><b>When the reduced resolution function is applied, the detection capability varies depending on your configuration. The following is the calculating formula.</b>  <b>[Detection capability under the reduced resolution function] = [Original detection capability] + [Beam axis spacing] * [a number of beam axes specified to be ignored and not monitored]</b></p> <p><b>Therefore, make sure to accurately calculate the safety distance according to the detection capability, and install the GL-R at a distance greater than or equal to the minimum safety distance away from the hazardous zone or hazard. The installation of additional safety measures, such as a safeguarding, may be required if the detection capability varies due to the configuration of reduced resolution. On your own responsibility, you must perform the risk assessment based on your configuration of reduced resolution in order to reduce the risk.</b></p>
---	---

There are two operation modes for the reduced resolution function.

## ■ Single-zone mode

In this mode, the GL-R ignores only one object which is smaller than the specified size.

The OSSD goes to the OFF-state when the total number of consecutive beam axes interrupted exceeds the number of beams that were selected to ignore obstacles.

On the other hand, the OSSD goes to the OFF-state when the interrupted beams are not consecutive, even if each individual object is smaller than the specified size and the total number of interrupted beams is not more than the number of ignored beams.

This mode is effective when only one object always exists in the detection zone.

### ● Example: The number of ignored beams is "2"

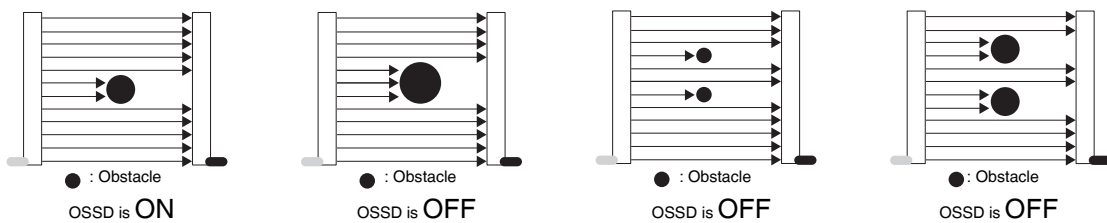

## ■ Multi-zone mode

In this mode, the GL-R ignores objects that are smaller than the specified size, even if more than one is in the detection zone at the same time. The OSSD only goes to the OFF state when the number of consecutive beam axes interrupted is greater than the number of selected beams to ignore.

### ● Example: The number of ignored beams is "2"

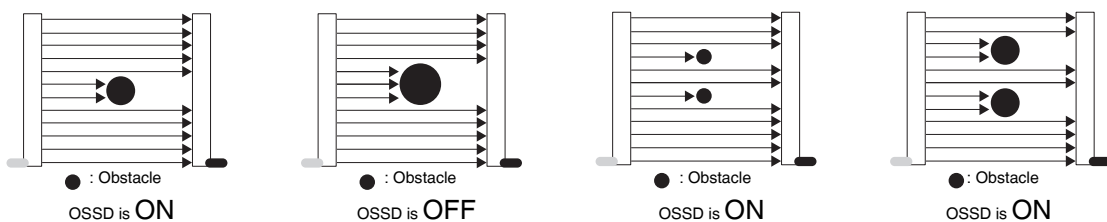

**! Point**

- When the GL-R operates in optical synchronization, the OSSD goes to the OFF-state if both the top and bottom beam axes on the main unit are blocked. This occurs even if the multi-zone mode is specified.
- The 7-segment display indicates "F" when the reduced resolution function is applied.  
 "Function Indicators and 7-segment Display" (page 5-2)

See  "Functions" (page 2-4) for the information of wiring system and cable type to activate this function.

**How to use**

- (1) Determine the number of beam axis to be ignored from the size of object.
- (2) Make sure to accurately calculate the detection capability according to the number of beam axis to be ignored.

Size of object to be ignored (mm)			Number of beam axis to be configured	Detection capability (mm)		
GL-RF	GL-RH	GL-RL		GL-RF	GL-RH	GL-RL
Max. φ6	Max. φ15	Max. φ35	1	φ24	φ45	φ85
Max. φ16	Max. φ35	Max. φ75	2	φ34	φ65	φ125
Max. φ26	Max. φ55	Max. φ115	3	φ44	φ85	φ165
:	:	:	:	:	:	:

**Reference**

[Ignored object size] = ( [Beam axis pitch] - [Lens diameter] ) × [Number of ignored beam axis] + [Lens diameter] × ( [Number of ignored beam axis] - 1 )

[Detection capability] = [Detection capability (default)] + [Beam axis pitch] × [Number of ignored beam axis]

Model	Beam axis pitch	Lens diameter	Detection capability
GL-RF	10	φ4	φ14
GL-RH	20	φ5	φ25
GL-RL	40	φ5	φ45

**Procedure for Configuration**

The reduced resolution mode can be configured either by using the setting switch or by using the configuration software. The configuration range for reduced resolution is different and depends on the configuration procedure used.

**■ Configuration by using the setting switch**

When the reduced resolution mode is configured by using the setting switch on the GL-R unit, the GL-R operates only in the single-zone mode. You can select one or two beam axes as the number of ignored beams. When the GL-R units are connected in series, the reduced resolution mode is according to the setting switch on the main unit. When the GL-R units are connected in series, the configuration of main unit is applied to the sub unit (the configuration is not applied individually).

 "1-2 Part Description" (page 1-10)

**■ Configuration by using the configuration software**

When the reduced resolution mode is configured by using the configuration software, you can specify the single-zone mode or multi-zone mode.

The number of ignored beams is automatically determined when you specify the size of the object to be ignored.

**! Point**

- If the unit to which the reduced resolution function is set contains different types of minimum detectable objects, the number of axes to be ignored is adjusted to the GL-R with the smallest type of minimum detectable object. The number of axes to be ignored cannot be set for each unit.
- If the reduced resolution are set with the configuration software, set the setting switch to "Disable". If the configurations for the setting switch and safety device setting software are duplicated, an error will occur.  
 "Setting switch" (page 1-11)

 "Reduced resolution" (page 6-20)

# 2-9 Wait Input Function

The wait input is a NON-SAFETY-RELATED function.

This function puts the OSSD into an OFF state through a signal from an external device (non safety-related device).

See "Functions" (page 2-4) for the information of wiring system and cable type to activate this function.

## How to use

- (1) The signal from the external non safety-related control device is connected to the wait input. When this signal is ON, the OSSD of the GL-R goes to OFF.
- (2) This function is useful for testing and making sure that the machine which the GL-R is installed on can stop within the specified period of time when the OSSD goes into an OFF state.

	<b>The wait output is not allowed to be connected to the safety output provided from the safety-related control system. Connection to the safety output of the safety-related control system may result in significant harm to the machine operators including serious injury or death.</b>
--	---

### ! Point

- The GL-R goes into an Interlock condition if the wait input is activated when using manual restart mode.  
 "2-4 Interlock Function" (page 2-7)
- The OSSD goes into an OFF state when the wait input is activated while the GL-R is in the muted condition. The GL-R returns to normal operation after the wait input is deactivated.  
 "Muting function" (page 2-13)

## Wiring

When using a PNP output type cable

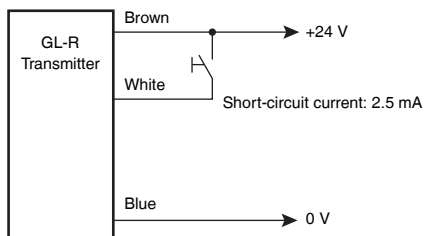

When using an NPN output type cable

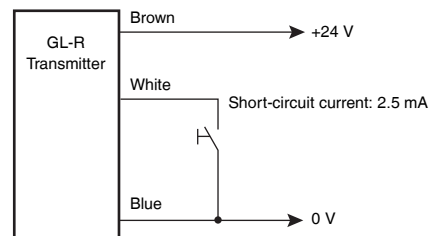

### ! Point

The switch must be rated at 24 V DC, 2 to 3 mA.



■ Time chart

Automatic restart mode

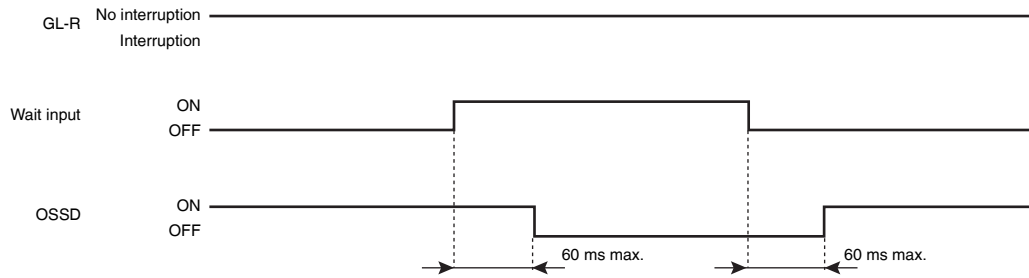

Manual restart mode

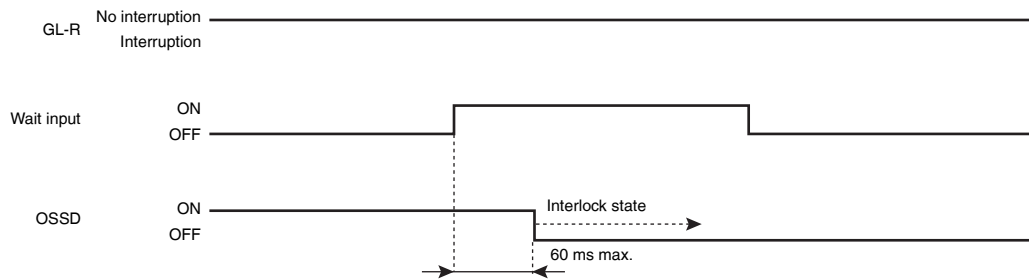

📖 "Interlock Function" (page 2-7)

Reference

For the GL-R, the 7-segment display indicates "U" if the wait input is activated. See 📖 "Function Indicators and 7-segment Display" (page 5-2)

# 2-10 Non Safety-Related Outputs

The outputs other than the OSSD are "non safety-related outputs" which inform a PLC or similar non-safety devices of the operations of the GL-R. All non safety-related outputs other than the muting lamp output can be selected and assigned to a wire by using the configuration software.

☞ "Output" (page 6-22)

All non safety-related outputs other than the muting lamp output can be connected to both PNP and NPN input devices. Refer to the time charts mentioned in this manual because the output logic is different depending on the connected device. On the other hand, the muting lamp output is an NPN open collector output.

☞ "4-2 I/O Circuit Diagram" (page 4-3)

## ■ Available non safety-related outputs according to the cable type

Cable type	Available non safety-related outputs on the transmitter	Available non safety-related outputs on the receiver
5-core cable	Nothing	Nothing
7-core cable	1 output (selectable)	Nothing
11-core cable	Muting lamp output and 1 output (selectable)	1 output (selectable)

The non safety-related outputs on the transmitter are available only when wired synchronization system is applied. ☞ "1-2 Part Description" (page 1-10)

	<p><b>The non safety-related output is not allowed to be used as a safety output for safety-related control systems. The non safety-related output does not constitute a part of the safety-related control system. Usage of the non safety-related output as a safety output may result in significant harm to the machine operators including injury or death.</b></p>
--	--

## ■ Selection of non safety-related output

One of the following six output functions is selected and assigned as the non safety-related output.

AUX (Auxiliary) Output (Default function on the red wire of the receiver cable)

☞ "AUX (Auxiliary) output (Default function on the red wire of the receiver cable)" (page 2-37)

Error output (Default function on the black wire of the transmitter cable)

☞ "Error output (Default function on the black wire of the transmitter cable)" (page 2-37)

Muted condition output

☞ "Muted condition output" (page 2-38)

Alert output

☞ "Alert output" (page 2-39)

Clear / Blocked output

☞ "Clear / Blocked output" (page 2-40)

Interlock reset ready output

☞ "Interlock reset ready output" (page 2-40)

The muting lamp output is assigned to the red wire of the transmitter cable and cannot be assigned to other wire of the cable.

☞ "Muting lamp output (The red wire of the transmitter cable)" (page 2-38)

## AUX (Auxiliary) output (Default function on the red wire of the receiver cable)

This output informs an external device (non safety-related device) of the operations of the GL-R and operates in synchronization with OSSD operation. It can only be connected to a PLC or similar non-safety devices. See  "Functions" (page 2-4) for the information of wiring system and cable type to activate this function.

### ● Time chart

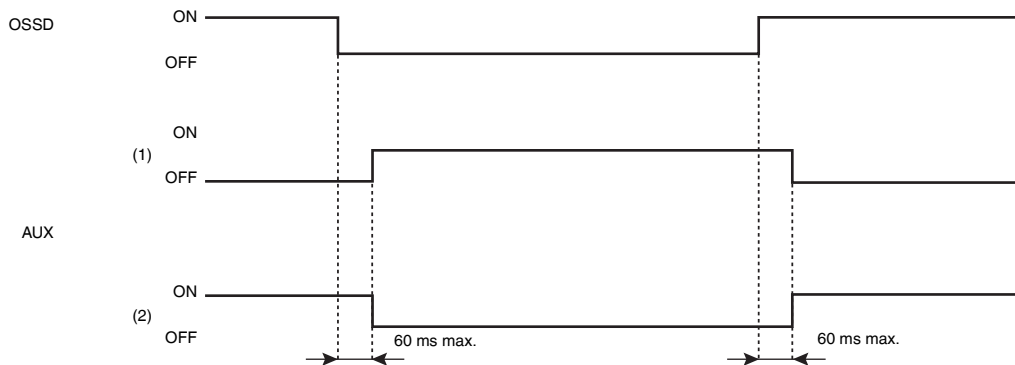

- (1) When using a PNP output type cable to connect to a PNP input device, or when using an NPN output type cable to connect to an NPN input device
- (2) When using a PNP output type cable to connect to an NPN input device, or when using an NPN output type cable to connect to a PNP input device

## Error output (Default function on the black wire of the transmitter cable)

The error output is activated if the GL-R goes to the error condition.

See  "Functions" (page 2-4) for the information of wiring system and cable type to activate this function.

### ● Time chart

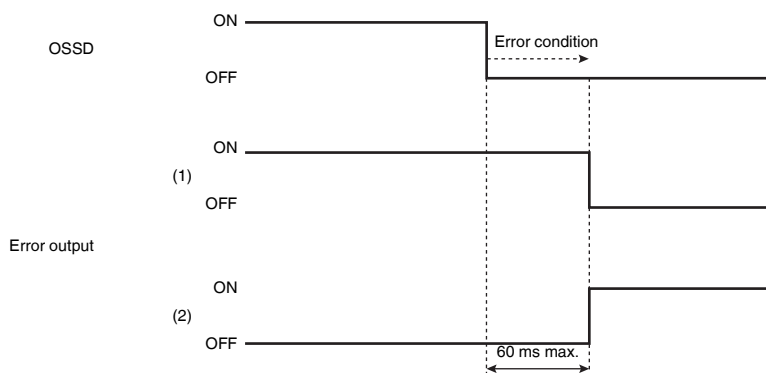

- (1) When using a PNP output type cable to connect to a PNP input device, or when using an NPN output type cable to connect to an NPN input device
- (2) When using a PNP output type cable to connect to an NPN input device, or when using an NPN output type cable to connect to a PNP input device

## Muting lamp output (The red wire of the transmitter cable)

This output is available only when using an 11-core cable for the transmitter. This output function is fixed to the red wire of the transmitter cable and cannot be replaced with the other output functions.

The muting lamp output is an output function to light up the muting lamp if the GL-R goes into the muted condition or override condition. The muting lamp is used to indicate the condition of GL-R.

Refer to the time chart mentioned in "Muted condition output".

See □ "Functions" (page 2-4) for the information of wiring system and cable type to activate this function.

### ● Muting lamp

When using the muting lamp, it must meet the following conditions.

For an incandescent lamp : rated 24 V DC, 1 to 5.5 W

For an LED indicator : rated current consumption must be 10 to 230 mA



Point

The muting lamp output is an NPN open collector output regardless of the cable type.

## Muted condition output

The muted condition output is activated if the GL-R goes into the muted condition or override condition.

See □ "Functions" (page 2-4) for the information of wiring system and cable type to activate this function.

### ● Time chart

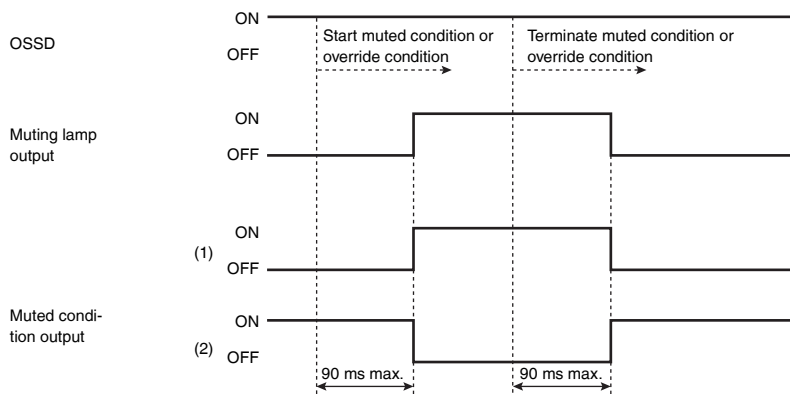

(1) When using a PNP output type cable to connect to a PNP input device, or when using an NPN output type cable to connect to an NPN input device

(2) When using a PNP output type cable to connect to an NPN input device, or when using an NPN output type cable to connect to a PNP input device

## Alert output

The alert output is activated if the amount of received light of at least one beam axis is unstable for more than 5 seconds.

See  "Functions" (page 2-4) for the information of wiring system and cable type to activate this function.

### ● Time chart

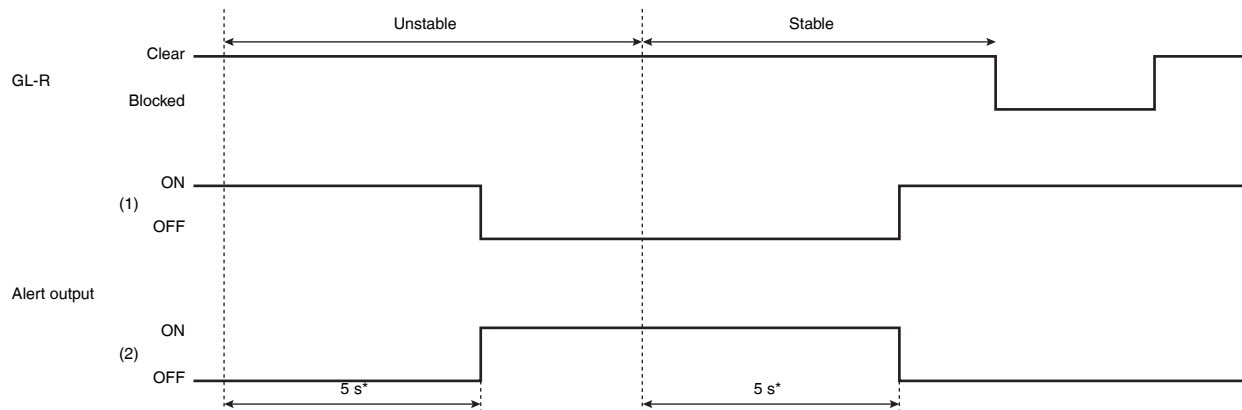

(1) When using a PNP output type cable to connect to a PNP input device, or when using an NPN output type cable to connect to an NPN input device

(2) When using a PNP output type cable to connect to an NPN input device, or when using an NPN output type cable to connect to a PNP input device

\* This can be configured as "Alert monitoring time" through the configuration software.  "Output" (page 6-22)

## Clear / Blocked output

The Clear/Blocked output informs the external devices (non-safety-related devices) whether the beam axes are clear or blocked. ("Clear" means no interruptions in the detection zone, "Blocked" means there is an interruption in the detection zone.)

For example, when the GL-R is in an interlock condition, the OSSD will turn OFF while the clear/blocked output indicates "clear". Another example is if the GL-R is muted or in override mode, the OSSD is ON but the clear/blocked output may indicate "blocked".



### Point

**When the partial muting function is applied, the clear/blocked output indicates the condition of beam axes which are in the muted condition.**

See "Functions" (page 2-4) for the information of wiring system and cable type to activate this function.

### ● Conditions when the clear state is detected

The Clear/Blocked output will turn ON when all beam axes are clear.

### ● Conditions when the blocked state is detected

The Clear/Blocked output will be deactivated if any of the below two conditions is met:

- When at least one beam axis is blocked.
- When the GL-R is in an error condition.

The output is turned off if one of the above two conditions is fulfilled.

### ● Time chart

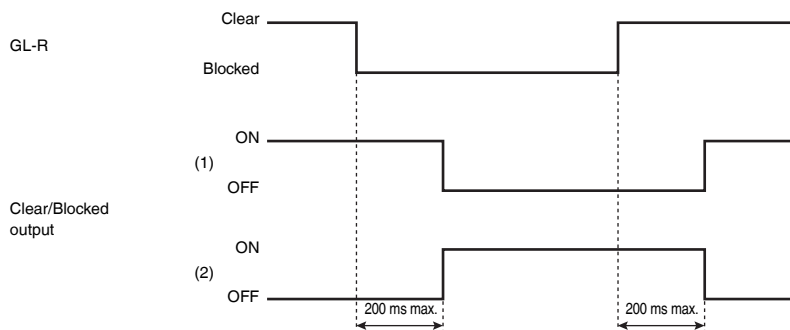

(1) When using a PNP output type cable to connect to a PNP input device, or when using an NPN output type cable to connect to an NPN input device

(2) When using a PNP output type cable to connect to an NPN input device, or when using an NPN output type cable to connect to a PNP input device

## Interlock reset ready output

The Interlock-reset-ready output is enabled when "Manual start / Automatic restart" or "Manual start / Manual restart" is set. This output informs the external devices (non-safety-related devices) that the interlock state on the GL-R is ready to be released by pressing the reset button because the GL-R does not detect any interruptions in the detection zone.

Refer to "2-4 Interlock Function" (page 2-7) for more information on the time chart and details of the interlock function.

# 3

## Installation to a Machine

---

---

3-1	Correct Installation Method . . . . .	3-2
3-2	Safety Distances . . . . .	3-4
3-3	Light Interference Prevention Method . . . . .	3-8
3-4	Installation Distance from Glossy Surfaces . . . . .	3-10
3-6	Mounting Brackets . . . . .	3-13
3-7	Front Protection Cover . . . . .	3-18
3-8	Optical Alignment . . . . .	3-19

# 3-1 Correct Installation Method

## Transmitter and receiver orientation

- The GL-R receiver and transmitter must be aligned in the same plane. The cables must exit from the same end of the light curtain.
- The GL-R must be installed so that the indicators on the transmitter and receiver face one another and are located at the same height.

### Correct mounting orientation

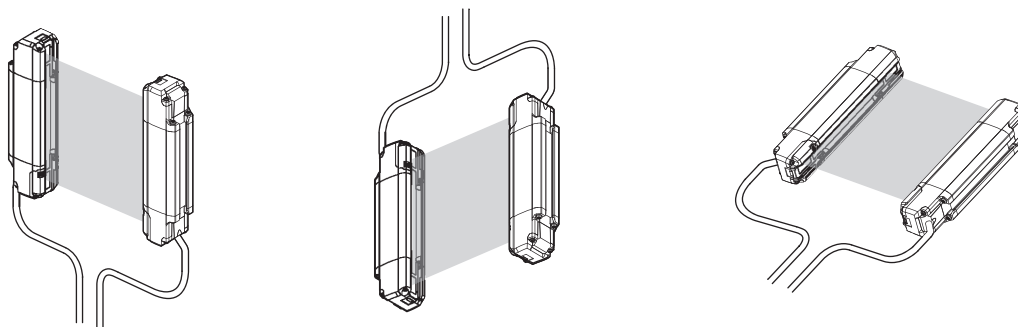

### Incorrect mounting orientation

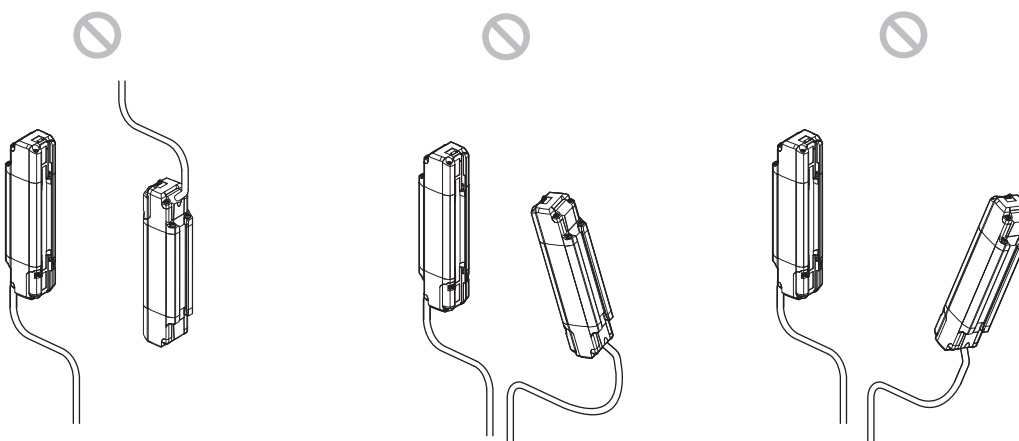

**!** Point

Make sure that the transmitter and receiver are of the same type (eg. GL-RxxH, or GL-RxxL) and size before installation. Never mix sizes or types.



## Mounting position

### Correct position

- The machine operators are only able to approach the hazardous zone or hazards by passing through the detection zone of the GL-R.
- While the machine is running, the machine operator must always stay on the opposite side of the hazardous zone or hazard.

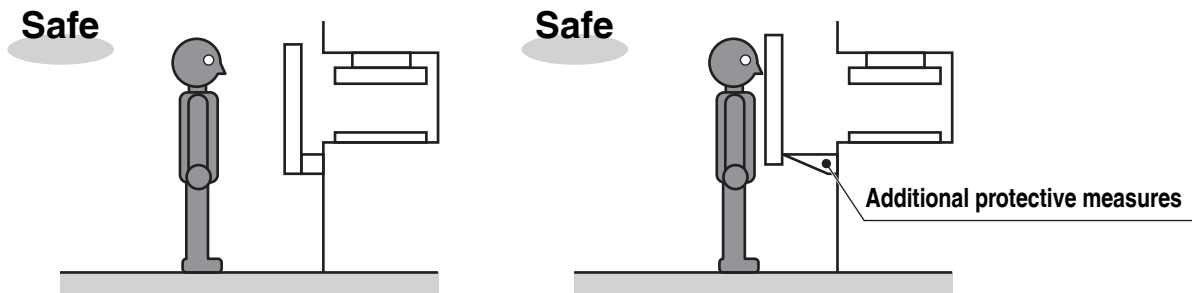

### Incorrect position

- The machine operator can access the hazardous zone or hazards without passing through the detection zone of the GL-R.
- While the machine is running, the machine operator or a part of machine operator's body can stay at the position between the detection zone of the GL-R and hazardous zone or hazard.



	<p><b>Additional protective measures, such as a mechanical safety guard, must be installed to protect areas not covered by the GL-R. NEVER install the GL-R in a manner which allows an operator to position his body or part of his body between the GL-R and the hazardous zone, without first passing through the plane of the GL-R. Failure to do so can result in serious bodily injury or death.</b></p>
---	--

## 3-2 Safety Distances

The safety distance is the minimum allowable mounting distance between the GL-R and the hazard point, which allows complete stoppage of hazardous motion before an individual reaches the hazard point. The starting point (origin) for the safety distance must be the center line of the GL-R's surface. (See below figure.)

The following safety distance calculations are for cases where the detection zone is perpendicular to the direction of approach.

For all other cases, you must refer to the laws, rules, regulations or standards of the country in which the GL-R is installed.

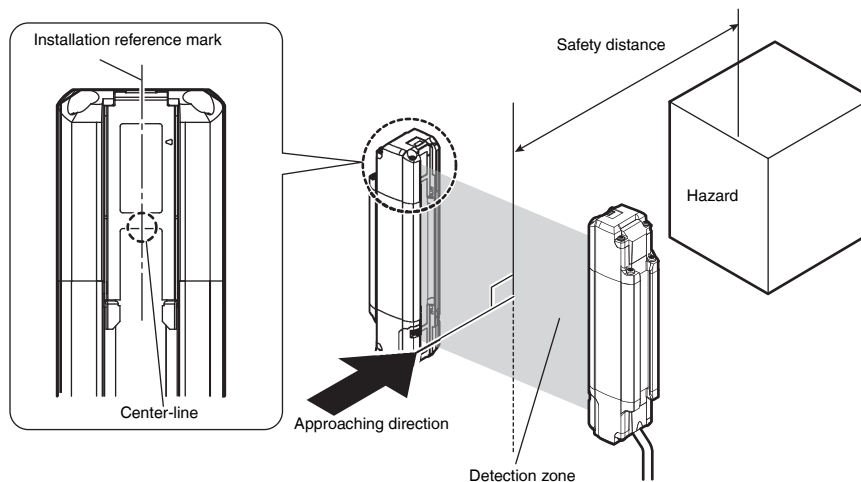

**! DANGER**

The installation of the GL-R must ensure the required safety distance in compliance with the requirements of laws, rules, regulations and standards of the country or region in which the GL-R is installed.

Mounting the GL-R closer to the hazard point than the calculated safety distance can result in serious bodily injury or death.

### ■ Example 1: ISO13855 (EN ISO13855)

Safety distance calculation according to ISO13855:2010 (EN ISO1385:2010) (in a case where the detection zone is perpendicular to the direction of approach)

Equation A:  $S = (K \times T) + C$

- S : Safety distance (mm)
- K : Approach speed of the body or parts of the body into the detection zone (mm/s)
- T : Overall system stopping performance (s) ( $T = t_1 + t_2$ )
- t<sub>1</sub> : GL-R maximum response time □ "Response time (OSSD)" (page 7-5)
- t<sub>2</sub> : Maximum time required by the machine to stop after receiving a signal from the protective equipment (GL-R), (s)
- C : Additional distance (mm) calculated from the GL-R detectable capability. See example below.

#### ● Calculation example for a detection capability of 40 mm (1.57") or less

The safety distance is calculated using Equation (A) and the parameters established in ISO13855 (EN ISO13855) with  $K = 2,000$  mm/s and  $C = 8(d - 14)$  mm. C is a value determined according to the GL-R detection capability diameter (mm), (d). The value (d) must be great than or equal to 0. This section provides an example of the calculation when using the GL-R08H (8 beam axes) which operates in wire synchronization system.

Equation B:  $S = 2,000 \text{ mm/s} \times (t_1 + t_2) + 8(d - 14 \text{ mm})$

$t_1 = 6.6$  ms and  $d = 25$  mm according to the specification, and if  $t_2 = 50$  ms:

$S = 2,000 \text{ mm/s} \times (0.0066 \text{ s} + 0.05 \text{ s}) + 8(25 \text{ mm} - 14 \text{ mm}) = 201.2 \text{ mm (7.92")}$

The safety distance calculated using the above Equation (B) must be 100 mm (3.94") or more.

(From ISO13855 Clause 6.2.3 and EN ISO13855 Clause 6.2.3)

If on the other hand the safety distance calculated using the above Equation (B) exceeds 500 mm (19.69"), set  $K = 1,600$  mm/s and calculate the safety distance again using Equation (A).

If the calculated safety distance is less than 500 mm (19.69"), you still must use a safety distance of  $S = 500$  mm (19.69"). (From ISO13855 Clause 6.2.3 and EN ISO13855 Clause 6.2.3)

#### ● Calculation example for a detection capability of 40 mm (1.57") or more and 70 mm (2.76") or less

This section provides an example of the calculation when using the GL-R30L (30 beam axes) which operates in optical system with Channel A.

The safety distance is calculated using Equation (A) and the parameters established in ISO13855 (EN ISO13855) with  $K = 1,600$  mm/s and  $C = 850$  mm (33.46").

$S = 1,600 \text{ mm/s} \times (t_1 + t_2) + 850 \text{ mm}$

$t_1 = 10.5$  ms according to the specification, and if  $t_2 = 50$  ms:

$S = 1,600 \text{ mm/s} \times (0.0105 \text{ s} + 0.05 \text{ s}) + 850 = 946.8 \text{ mm (37.28")}$

Accordingly, the safety distance for this application is  $S = 946.8$  mm (37.28")

■ **Example 2 :ANSI B11.19-2010**

**Safety distance calculation according to ANSI B11.19-2010 (in a case where the detection zone is perpendicular to the direction of approach)**

**Equation:**  $D_s = (K \times T) + D_{pf}$

- Ds : Safety Distance (inch)
  - K : The maximum speed that an individual can approach the hazard
  - T : The total time that it takes for the hazardous motion to stop, or for the hazardous portion of the machine cycle to be completed. This value includes portions of time that vary by machine type and by the safeguarding device applied.
  - Dpf : The distance (depth) penetration factor. This value varies depending on the GL-R detection capability. Dpf=3.4 (S-0.275) inch. See the following figure.
- Penetration factor, Dpf, for presence-sensing devices used in a vertical application with object sensitivity less than 64 mm (2.5 inches)

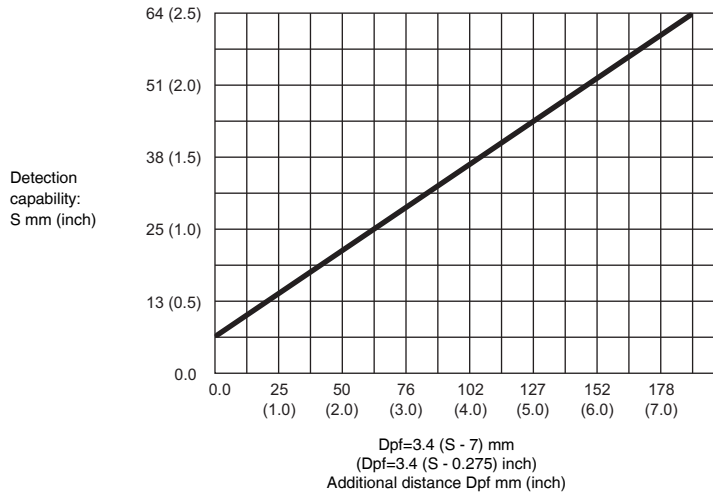

One of the accepted values for K is the hand speed constant. (It is usually considered as the horizontal motion of the hand and arm while seated). The common value is 1.6 m/s (63inch/s), although other values (typically greater) are also used. The hand speed constant does not include other body movements, which can affect the actual approach speed. Consideration for the above factors should be included when determining the speed constant for a given application. OSHA 1910.217(c) provides K = 63 inch/s (= 1,600 mm/s) as a recommended value.

📖 For more detailed information, such as calculating the value of "T", see ANSI B11.19-2010, Annex D.

### ■ Example 3 :ANSI/RIA R15.06-1999

Safety distance calculation according to ANSI/RIA R15.06-1999 (in a case where the detection zone is perpendicular to the direction of approach)

$$\text{Equation: } S = [K \times (T_s + T_c + T_r)] + D_{pf}$$

- S : Safety distance (mm)  
 K : Approach speed of the body or parts of the body into the detection zone (= 63 inch/s)  
 T<sub>s</sub> : Final stop time required when stop control is issued to machine (s)  
 T<sub>c</sub> : Maximum response time of machine's control system (s)  
 T<sub>r</sub> : Maximum response time of the GL-R and its interface (s)  
 D<sub>pf</sub> : Additional distance (mm) from the approach factor as in the following figure. This value varies depending on the GL-R detection capability.

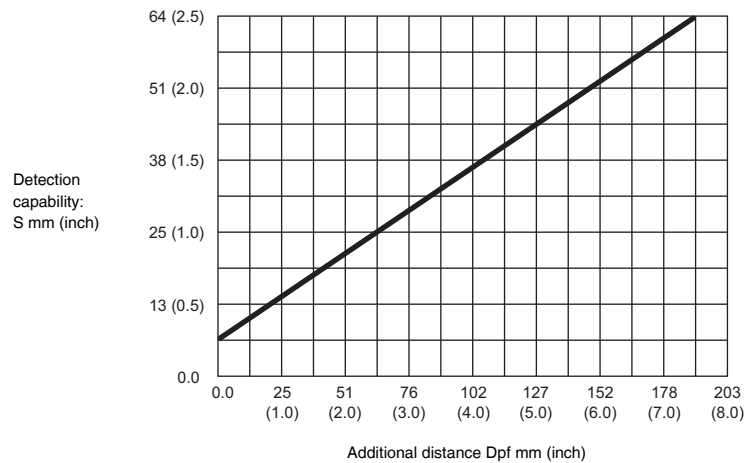

ANSI/RIA R15.06-1999 establishes  $K = 63 \text{ inch/s} (= 1,600 \text{ mm/s})$  as a minimum speed.

When more than one GL-R systems are installed, the OSSD may go to the OFF-state by the light interference between GL-R units.

There are three light interference prevention methods as follows.

### Light Interference Prevention Function

#### ■ When wire synchronization or one-line system is applied

The light interference prevention function automatically reduces mutual interference between GL-R units.

#### ■ When optical synchronization system is applied

The light interference prevention function is applied according to Channel configuration.

The mutual interference is reduced between GL-R units with Channel A and Channel B.

The mutual interference is not reduced between GL-R units with Channel 0 and Channel 0, GL-R units with Channel 0 and Channel A, or GL-R units with Channel 0 and Channel B.

Channel is configured by using the setting switch on the lower part of front side of GL-R units.

Configure the same Channel to the setting switch on both the transmitter and receiver.

For more information about the setting switch, see "Part Description" (page 1-10).

When the GL-R is in series connection, the setting switch configuration of the main unit is applied regardless of the setting switch configuration of the sub unit.



The response time varies according to the configuration of Channel.

"Response time (OSSD)" (page 7-5)

"Wiring System" (page 2-2)

### Series connection

Connecting the GL-R units in series can prevent mutual interference.

"Series connection" (page 2-3)

### Interference due to installation

If more than three GL-R systems are installed and not connected in series, they should be installed according to the following information.

#### (1) Install shielding

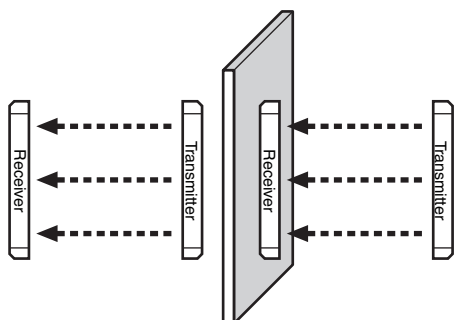

#### (2) If shielding is not possible: Ensure the transmitters are back-to-back, so as not to directly face each other.

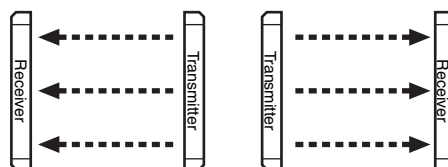

(3) Tandem installation: Alternate the transmitter and receiver sides.

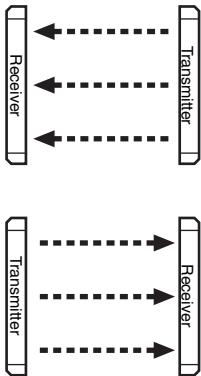

(4) Side-by-side installation: Alternate the transmitter and receiver sides.

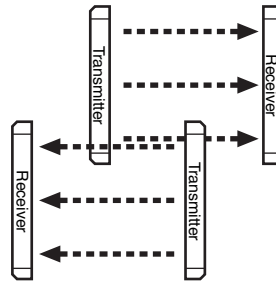

(5) If the transmitters and receivers must be on the same side: Ensure adequate distance between curtain pairs.

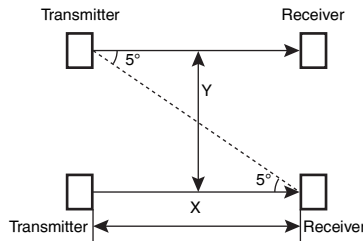
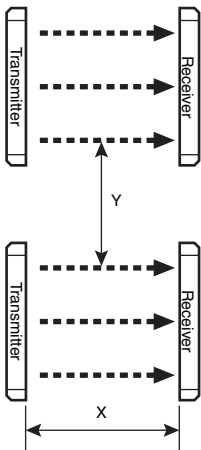

Operating distance "X"	Minimum installation distance "Y"
Less than 3 m	0.26 m
3 m or more	$X \times \tan 5^\circ = 0.0875 X$

**! Point**

When installing the GL-R in method (2), (3) or (4), installing the devices too closely may cause reflection in the plane of detection and thus cause interference. Total prevention of light interference may not be possible even following methods (1) to (5). The operator in charge must consider adequate light interference prevention method according to the machine or system where their GL-R is installed.

# 3-4

## Installation Distance from Glossy Surfaces

If there is a glossy surface around the GL-R, the GL-R may be affected and may not detect an interruption in the detection zone.

To avoid this problem, installation must be done according to the following:

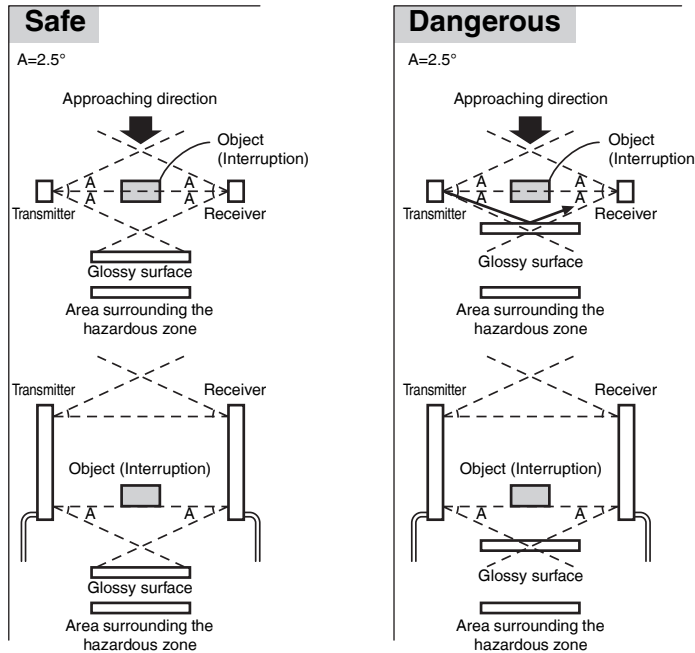

When determining a specific installation distance, refer to the following values including the installation tolerance.

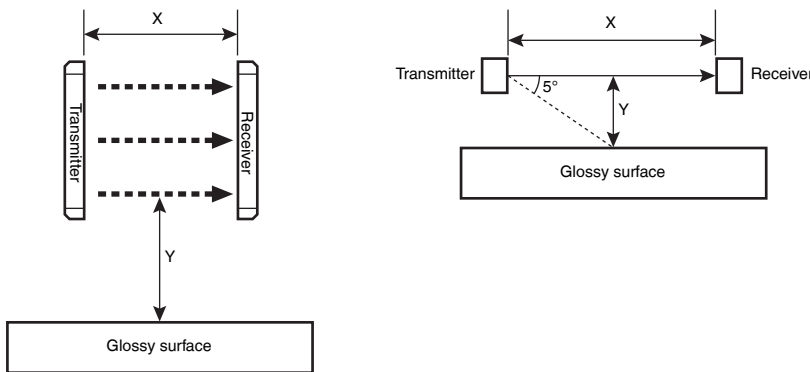

Operating distance "X"	Minimum installation distance "Y"
Less than 3 m	0.13 m
3 m or more	$X/2 \times \tan 5^\circ = 0.0437 X$



# 3-5 Cable Installation

Cables must be installed to the GL-R before the mounting brackets are installed.

## Overview

### ● Optical/wire synchronization system

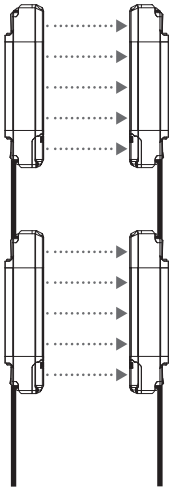

### ● One-line system

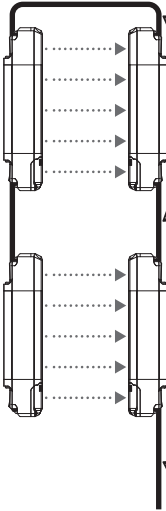

#### ● Series connection cable

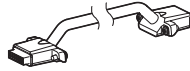

#### ● Unit connection cable

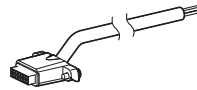

#### ● Unit connection cable (for extension use) + Extension cable

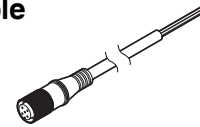
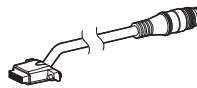

\* The unit connection cable can not be connected on the upper part of the GL-R.

	<ul style="list-style-type: none"> <li>• Do not remove the black gasket installed on the connector. Without this gasket the requirement of IP65 and IP67 cannot be fulfilled.</li> <li>• Securely tighten the cable connector and end cover with the screw in accordance with the torque values specified in this user's manual. Without proper installation, the requirement of IP65 and IP67 cannot be fulfilled.</li> </ul>
--	--

	<ul style="list-style-type: none"> <li>• Connect the unit connection cable to the connector port on the lower part of the GL-R. Removing the end cover on the upper part of the GL-R and connecting the unit connection cable may result in GL-R failure.</li> <li>• Do not remove the end cover installed on the upper part of the receiver except when you connect the series connection cable. If the end cover on receiver is removed, an error occurs.</li> </ul>
--	--

**Cable connection to the lower part of the GL-R (The unit connection cable and extension cable)**

Reference

The unit connection cable and extension cable can be used for both the transmitter and receiver.

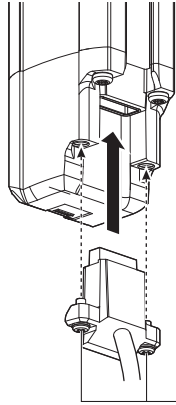

M3 cross slot screws (Recommended tightening torque of 0.3 N•m)

**Cable connection to the upper part of the GL-R (The series connection cable)**

Reference

The series connection cable can be used on both the transmitter and receiver.

1

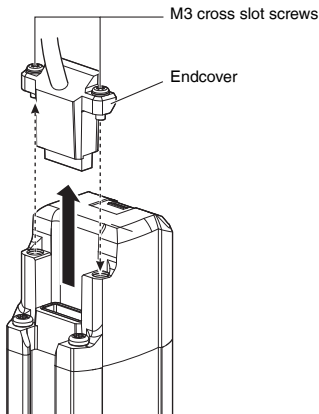

2

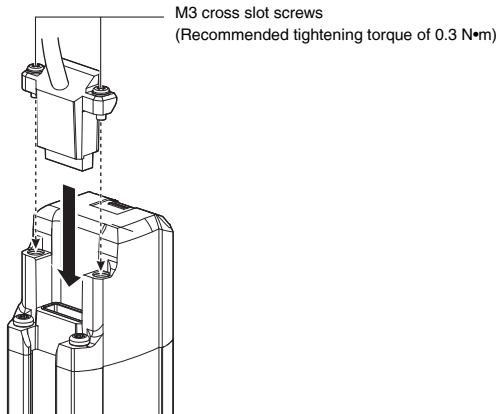

**! DANGER**

When the GL-R units are wired by the one-line system, the end cover removed from the upper part of the GL-R must be secured to the lower part with the screw. (Recommended tightening torque of 0.3 N•m)

# 3-6 Mounting Brackets

**! DANGER** The proper installation of the device should be verified according to the procedure outlined in "Regular (periodical) inspection" (page A-11) in the event that maintenance requires the removal of the device from its target equipment or the adjustment of its installation position after its initial installation onto that target equipment. Failure to follow this installation instruction may result in significant harm to the machine operators, including serious injury or death.

**! Point** Connect the cables to the GL-R before connecting the mounting brackets. If the mounting brackets are connected before the cables, the cable may be disconnected or poor connection. "Cable Installation" (page 3-11)

## Adjustable angle mounting bracket (GL-RB01/GL-RB02)

**! Point** If the length for a single GL-R unit is 1280 mm or greater, use the antivibration bracket for the adjustable angle mounting bracket additionally as an intermediate support bracket. For more information about the mounting position, see "Dimensions" (page 7-12)

**1** Insert the adjustable angle mounting bracket into the GL-R along the groove on the back side, as shown in the following image.

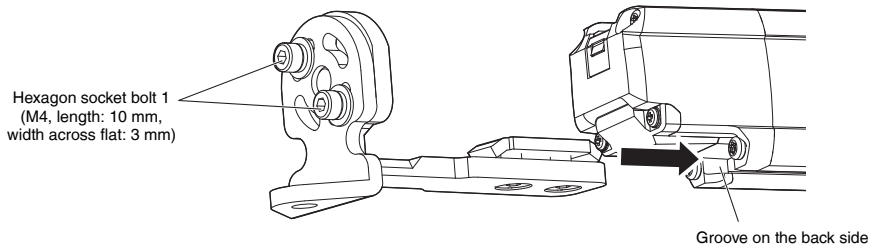

**2** Secure standard mounting bracket A to the GL-R with hexagon socket bolt 2 on the back side.

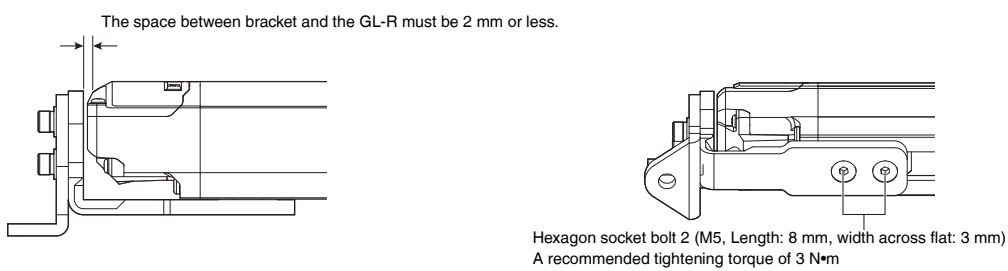

**3** Adjust the installation angle of the GL-R for optical alignment and secure the standard mounting bracket A to the GL-R with the hexagon socket bolt 1.

**Reference** There are three types of mounting directions according to the positions of hexagon socket bolt 1. Additionally, the angle can be adjusted precisely in the range of 45°

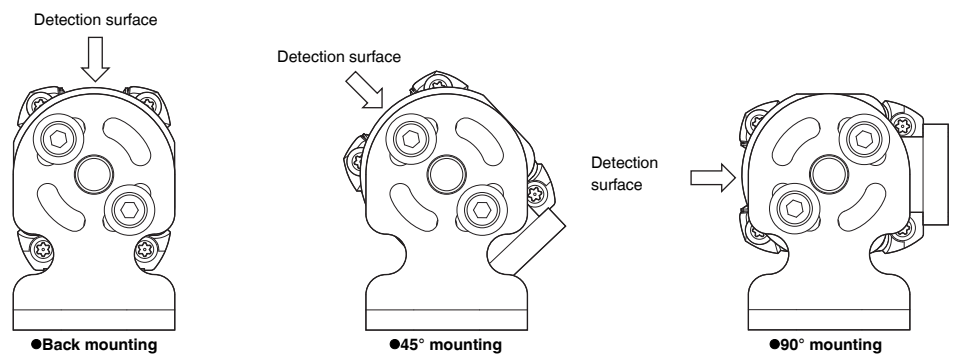

**Straight mounting bracket (GL-RB11) / L-shaped mounting bracket (GL-RB12)**

**! Point**

If the length for a single GL-R unit is 1280 mm or greater, use the following antivibration bracket additionally as an intermediate support bracket.

- If you use Straight mounting bracket, use Antivibration bracket for the straight mounting bracket.
- If you use L-shaped mounting bracket, use L-shaped mounting bracket as an antivibration bracket.

For more information about the mounting position, see  "Dimensions" (page 7-12)

**1** Insert the mounting bracket into the GL-R along the groove on the back side, as shown in the following image.

**Straight mounting bracket**

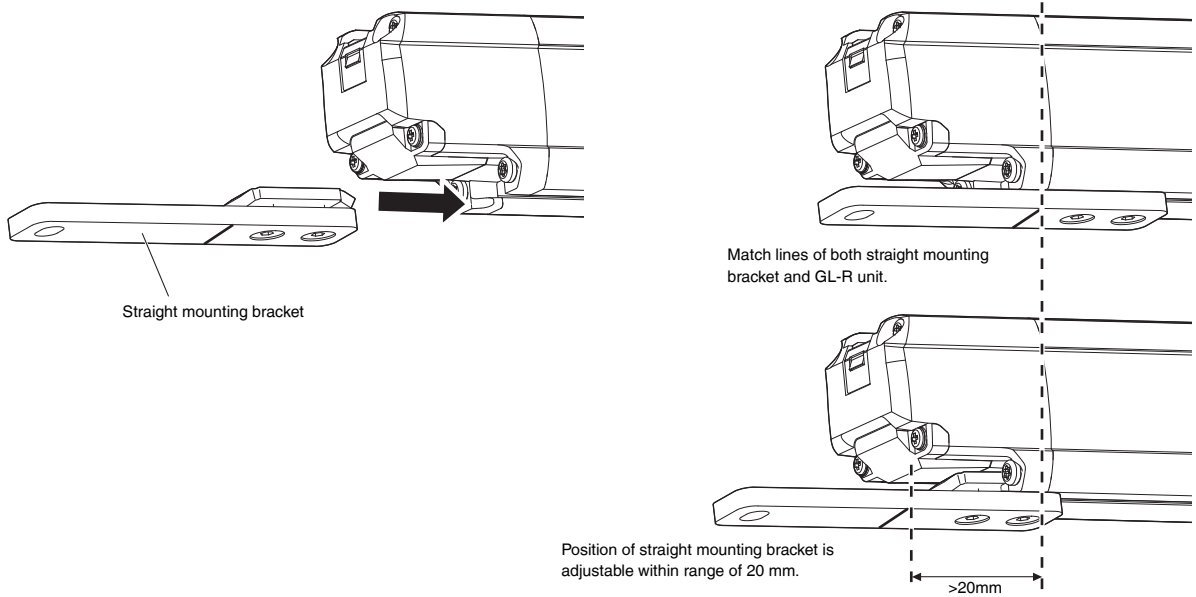

**L-shaped mounting bracket**

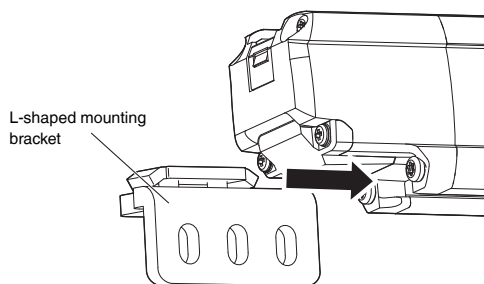

**2** Secure the mounting bracket to the GL-R with hexagon socket bolt on the back side.

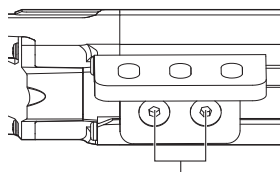

Hexagon socket bolt 2 (M5, Length: 8 mm, width across flat: 3 mm)  
A recommended tightening torque of 3 N•m

**No dead zone mounting bracket (GL-RB21)**

**! Point**

- If the length for a single GL-R unit is 1280 mm or greater, use the antivibration bracket for the adjustable angle mounting bracket additionally as an intermediate support bracket. For more information about the mounting position, see "Dimensions" (page 7-12)
- For GL-R08H and GL-R04L, attach one bracket to the transmitter and receiver respectively.

**1 Install the no dead zone mounting bracket to the machine.**

The screws for installation on the machine are not supplied. Please acquire on your own.

**When installed in front direction**

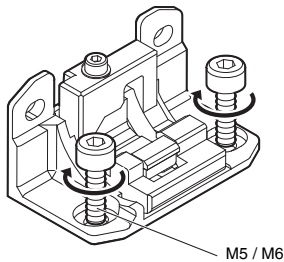

**When installed in 90° direction**

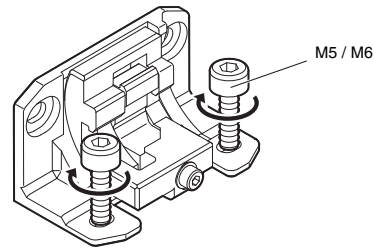

**2 Insert the stoppers on the no dead zone mounting bracket into the GL-R along the groove on the back side of the GL-R, Then, the no dead zone mounting bracket must be loosely secured on a temporary basis with a hexagon socket bolt.**

At this point, you can adjust the installation angle of the GL-R while the no dead zone mounting bracket is secured to the GL-R.

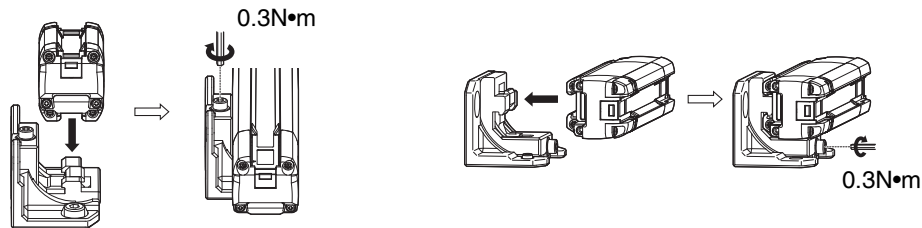

**3 The installation angle of the GL-R can be adjusted in the range of ±15° for optical alignment.**



**4 After adjustment of the installation angle, the no dead zone mounting bracket must be secured tightly with a hexagon socket bolt. (Recommended tightening torque of 3.0N·m)**

**Reference**

Remove the GL-R from mounting bracket as follows after the hexagon socket bolt is loosed.

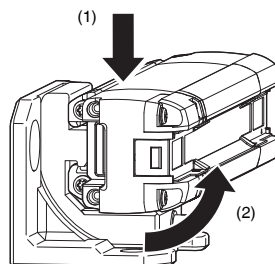

### Antivibration bracket for the adjustable angle mounting bracket (GL-RB32)

If the length for a single GL-R unit is 1280 mm or greater, and you use the adjustable angle mounting bracket or no dead zone mounting bracket, use the antivibration bracket for the adjustable angle mounting bracket additionally as an intermediate support bracket.

For more information about the mounting position, see "Dimensions" (page 7-12).

**1 Install the antivibration bracket for the adjustable angle mounting bracket to the machine.**

The screws for installation to the machine are not supplied. Please acquire on your own.

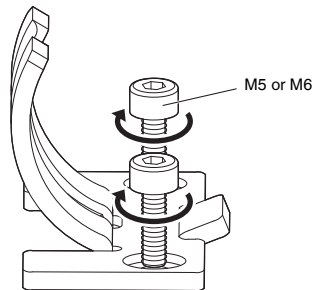

**2 Insert convex A on the back side of the elastomer part into the groove on the metal part.**

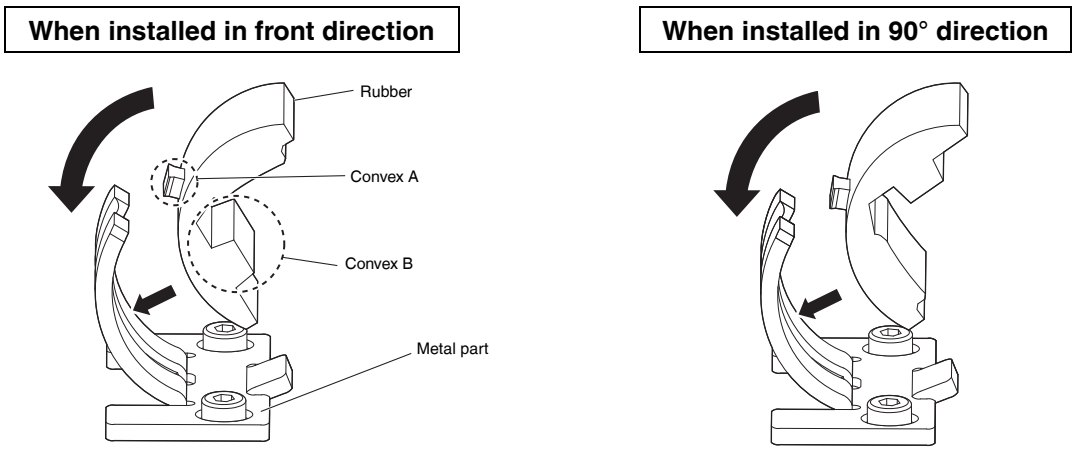

**3 Insert convex B on the antivibration bracket into the GL-R along the groove on the back side of the GL-R.**

The vibration from the machine to GL-R is suppressed by the antivibration mounting bracket between the machine and GL-R. The GL-R must be installed on the machine with the mounting brackets.

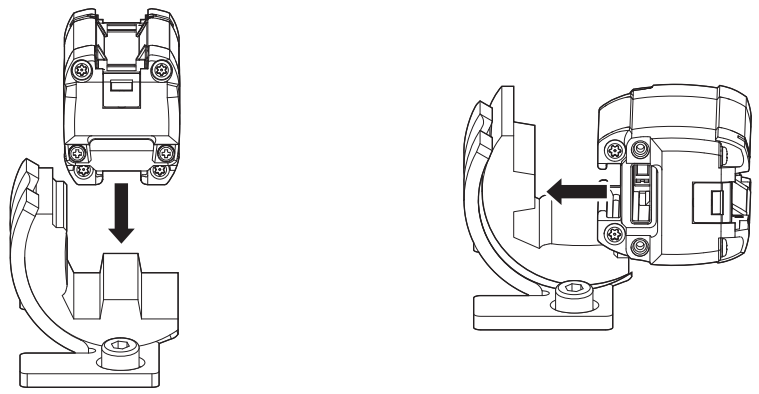

## Antivibration bracket for the straight mounting bracket (GL-RB31)

If the length for a single GL-R unit is 1280 mm or greater, and you use the straight mounting bracket, use the antivibration bracket for the straight mounting bracket additionally as an intermediate support bracket.

For more information about the mounting position, see  "Dimensions" (page 7-12).

- 1 Install the hexagon socket bolts and spacers to the machine. The bolts and spacers are delivered with the bracket. (Recommended tightening torque of 4N•m).

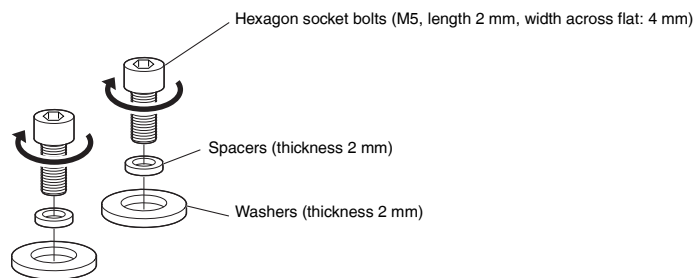

- 2 Insert the antivibration elastomer into the hexagon socket bolts.

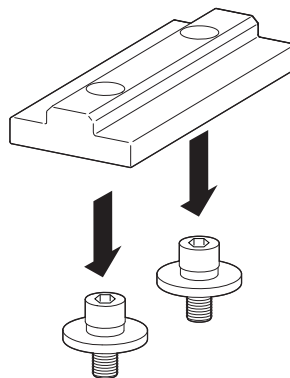

- 3 Insert the antivibration elastomer into the GL-R along the groove on the back side, as shown in the following image.

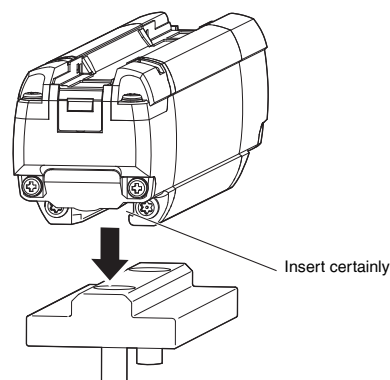

### Point

Push the antivibration mounting bracket tightly to make sure that the antivibration elastomer is inserted into the groove on the GL-R.

# 3-7 Front Protection Cover

3

Installation to a Machine

**1** Fit one side hook of the front protection cover along the side line of GL-R. Then fit in the another side hook to the GL-R.

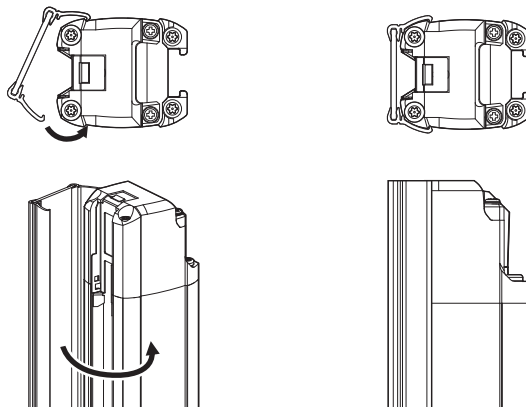

**2** Adjust the position of the front protection cover so that the edge is even with the GL-R.

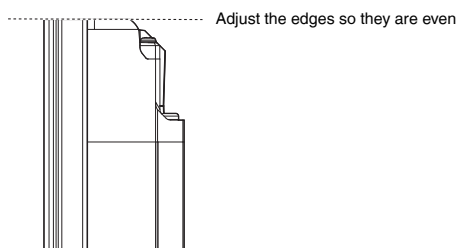

**!** Point

When the front protection cover is installed, the maximum operating distance is shortened as follows.

Number of front protection cover installed	Maximum operating distance		
	GL-RF	GL-RH	GL-RL
One cover (on the transmitter or receiver)	9.5 m	14.5 m	
Two covers (on the transmitter and receiver)	9 m	14 m	





# 3-8 Optical Alignment

## Ensure the following prior to optical alignment

- No interruption in the detection zone of the GL-R.
- The surface of the transmitter and the receiver are clean.

## Alignment procedure

1. Both the transmitter and receiver must be installed facing each other. Adjust the angle of the mounting brackets until the center indicators lights up green.  
The top and bottom center indicators show the light reception status of the top and bottom beam axes. Adjust the misaligned beam axes by observing these indicators.  
 "Function Indicators and 7-segment Display" (page 5-2)  
 "Center Indicator" (page 5-4)
2. Alignment must be completed at the center of the angle range in which the "OSSD" indicator remains green.
3. After completing optical alignment, the screws for the mounting brackets must be secured.  
Angle adjustment bracket: 3N•m  
No dead zone mounting bracket: 3N•m

 **Point**

**If all center indicators do not light up green even though the optical alignment for the GL-R has been completed, check the following points:**

- **At first, try to do the alignment for the top and bottom beam axes.**
- **The transmitter and receiver are installed at same level to each other.**
- **The part of machine onto which the transmitter is installed and the other part of machine onto which the receiver is installed must be fixed and parallel to each other.**
- **When the optical synchronization system is applied, the center indicators on the transmitter are all OFF.**  
 "1-2 Part Description" (page 1-10)

## Alignment using laser alignment tool

This laser alignment tool (model: GL-R1LP) can be used to assist optical axis alignment. You can shorten the time of the optical axis alignment, or roughly align the optical axis even when the power to the GL-R is not turned on.

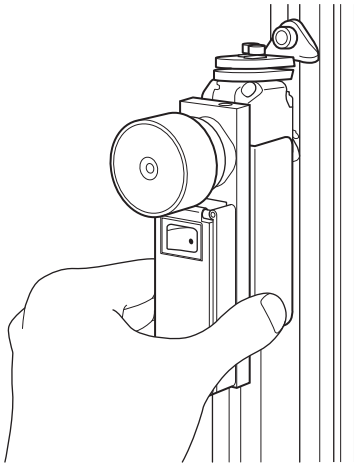

- 1** Align the GL-R1LP with the top of the transmitter, and then turn on the GL-R1LP. Align the optical axis so that laser light strikes the upper center of the opposite receiver.

**NOTICE**

To ensure the GL-R1LP does not fall, use your hand to support the GL-R1LP while using it.

- 2** In the same way, align the GL-R1LP with the bottom of the transmitter, and then adjust the optical axis.
- 3** Align the GL-R1LP with the upper part of the opposite receiver, and then adjust the optical axis.
- 4** In the same way, align the GL-R1LP with the bottom of the receiver, and then adjust the optical axis.

# 4

## Wiring

---

---

4-1	Precautions on Wiring and Power Supply .....	4-2
4-2	I/O Circuit Diagram .....	4-3
4-3	Cable Color and Pin Position .....	4-4
4-4	Cable Specification .....	4-8
4-5	Examples of Wiring .....	4-9



- The two OSSD outputs provided in the GL-R must both be used to establish a safety-related machine control system. Establishing a safety-related machine control system with just one OSSD output cannot be done because a potential OSSD output malfunction could result in significant harm to the machine operators, including serious injury or death.
- When using PNP output cables, do not cause a short circuit between the OSSD output and +24 V. Otherwise, OSSDs stay ON and create a dangerous situation.
- When using PNP output cables, be sure to connect the load between the OSSD and 0 V to avoid a dangerous situation. If the load is incorrectly connected between the OSSD and +24 V, the logic of OSSD operation will be reversed, and then turn ON when the GL-R detects the interruption in the detection zone. This is a dangerous situation.
- When using NPN output cables, do not cause a short circuit between the OSSD output and 0 V. Otherwise, OSSDs stay ON and create a dangerous situation.
- When using NPN output cables, be sure to connect the load between the OSSD and + 24 V to avoid a dangerous situation. If the load is incorrectly connected between the OSSD and 0 V, the logic of OSSD operation will be reversed, and the OSSD will turn ON when the GL-R detects the interruption in the detection zone. This is a dangerous situation.
- Regardless of whether the cables are PNP or NPN type, you must fulfill the requirements of Clause 9.4.3 in IEC60204-1: 2005 for protection against maloperation due to earth fault.
- All outputs, other than OSSDs, are not allowed to be used as safety outputs for a safety-related machine control system. Usage of these output functions, other than OSSDs, as a safety output could result in serious injury or death.
- To avoid the risk of electric shock, do not connect any of the GL-R inputs to DC power sources outside of the range of 24 V DC +20% or to any AC power source.
- To avoid the risk of electric shock, be sure that any hazardous voltage is isolated from all wiring of the GL-R with reinforced insulation or double insulation.
- Do not install the electric wiring of the GL-R together with or in parallel with any high-voltage electrical or power lines.

## Power supply

In order to meet the requirements laid out in IEC61496-1, UL61496-1, EN61496-1 and UL508, the power supply for the GL-R must meet the conditions listed below.

- A rated output voltage of 24 V DC (SELV, Overvoltage Category II) within  $\pm 20\%$ .
- Double insulation or reinforced insulation between the primary and secondary circuits.
- Output holding time of 20 ms min.
- A power supply must meet the requirements of the electrical safety and electromagnetic compatibility (EMC) regulations or standards in all countries and/or regions where the GL-R is used.
- A secondary circuit of power supply (output) must meet the requirements for Class 2 Circuits or Limited Voltage/Current Circuits specified in UL508, if the GL-R is used in United States or Canada.

### NOTICE

If the power supply for the GL-R is shared with other electronic devices, voltage reduction to the GL-R may occur due to the temporary increase of the current consumption on these devices, or the GL-R may be affected by the noise generated by these devices. When these situations occur, the GL-R may go into error condition. It is therefore strongly recommended that the power supply for the GL-R is dedicated solely for use with the GL-R, the muting device connected to the GL-R and the load for the GL-R. It should not be shared with other machines, devices or electronic devices.

# 4-2 I/O Circuit Diagram

Output circuit (PNP type cable)

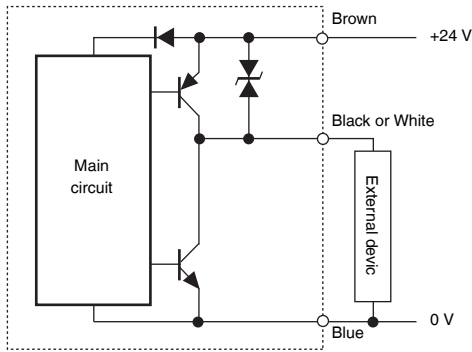

Output circuit (NPN type cable)

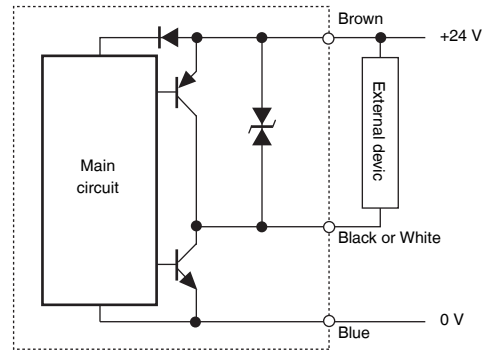

Input circuit (PNP type cable)

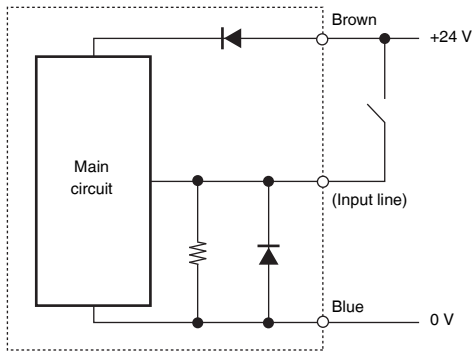

Input circuit (NPN type cable)

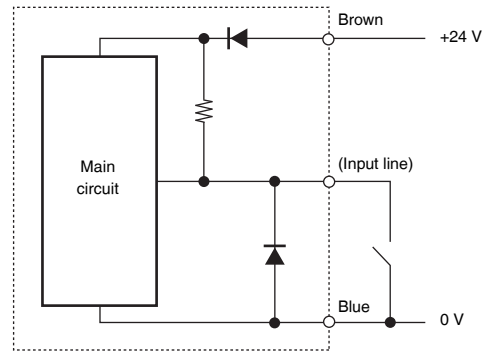

Non safety-related output circuit (NPN Cable / PNP Cable)

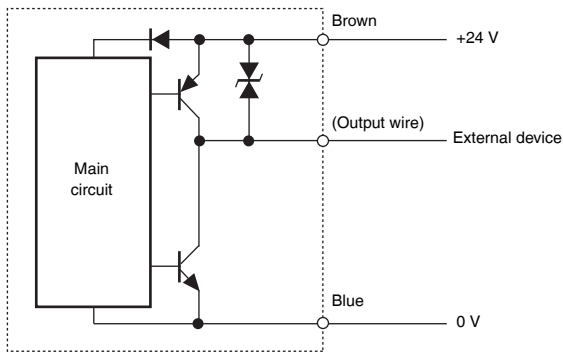

**Reference**

- Grey wire (FE) is electrically-connected to the light curtain body case.
- The light curtain body case and internal power signal lines are coupled by capacitor (3 kV, 100 pF).

**! Point**

- When the synchronization wire 1 or 2 is not connected, the GL-R operates in optical synchronization system.  
 □ "Wiring System" (page 2-2)
- When optical synchronization system or one-line system is applied, the input and output functions on the transmitter are not available.
- The functions assigned to the input and output may differ according to the configuration when setting through the configuration software.  
 □ "Chapter 6 Setting Method Using the Configuration Software" (page 6-1)

## Pin position (default)

### ■ 5-core cable

Pin No	Wire Color	Assigned function	
		Transmitter	Receiver
1	Brown	+24 V	+24 V
2	White	(Not in use)	OSSD2
3	Blue	0 V	0 V
4	Black	(Not in use)	OSSD1
5	Grey	FE	FE

Reference

M12 connector male pin assignment

M12 connector female pin assignment

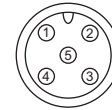
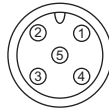

### ■ 7-core cable

Pin No	Wire Color	Assigned function	
		Transmitter	Receiver
1	White	Wait input	OSSD2
2	-	(Not in use)	(Not in use)
3	Black	Error output	OSSD1
4	Brown	+24 V	+24 V
5	Orange	Synchronization 1 (RS485_+)	Synchronization 1 (RS485_+)
6	Orange/Black	Synchronization 2 (RS485_-)	Synchronization 2 (RS485_-)
7	Blue	0 V	0 V
8	Grey	FE	FE

Reference

M12 connector male pin assignment

M12 connector female pin assignment



## ■ 11-core cable

Pin No	Wire Color	Assigned function	
		Transmitter	Receiver
1	White	Wait input	OSSD2
2	–	(Not in use)	(Not in use)
3	Black	Error output	OSSD1
4	Yellow	Override input	RESET input
5	Orange	Synchronization 1 (RS485_+)	Synchronization 1 (RS485_+)
6	Orange/Black	Synchronization 2 (RS485_-)	Synchronization 2 (RS485_-)
7	Blue	0 V	0 V
8	Red	Muting lamp output	AUX (auxiliary) output
9	Red/Black	Muting input 2	EDM input
10	Brown	+24 V	+24 V
11	Pink	Muting input 1	Interlock selection input
12	Grey	FE	FE

Reference

M14 connector male pin assignment

M14 connector female pin assignment



Reference

The Error output and AUX output function can be changed to other non safety-related output function through the configuration software.

Detail information for the output functions, see "Non Safety-Related Outputs" (page 2-36)

**Pin position (when not default output functions are assigned)**

The functions assigned to the input and output may differ according to the configuration when setting through the configuration software.

📖 "Chapter 6 Setting Method Using the Configuration Software" (page 6-1)

■ **When "Assign Muting input to receiver" is selected.**

📖 "(1) Muting" (page 6-17)

● **When "Apply EDM" is not selected and the interlock function can be configured.**

Transmitter: 7-core cable

Pin No	Wire Color	Assigned function
1	White	(Not in use)
2	–	(Not in use)
3	Black	Error output
4	Brown	+24 V
5	Orange	Synchronization 1 (RS485_+)
6	Orange/Black	Synchronization 2 (RS485_-)
7	Blue	0 V
8	Grey	FE

Receiver: 11-core cable

Pin No	Wire Color	Assigned function
1	White	OSSD2
2	–	(Not in use)
3	Black	OSSD1
4	Yellow	RESET input
5	Orange	Synchronization 1 (RS485_+)
6	Orange/Black	Synchronization 2 (RS485_-)
7	Blue	0 V
8	Red	<b>Muted condition output</b>
9	Red/Black	<b>Muting input 1</b>
10	Brown	+24 V
11	Pink	<b>Muting input 2</b>
12	Grey	FE

● **When "Apply EDM" is selected and the interlock function mode is automatic restart.**

Transmitter: 7-core cable

Pin No	Wire Color	Assigned function
1	White	(Not in use)
2	–	(Not in use)
3	Black	Error output
4	Brown	+24 V
5	Orange	Synchronization 1 (RS485_+)
6	Orange/Black	Synchronization 2 (RS485_-)
7	Blue	0 V
8	Grey	FE

Receiver: 11-core cable

Pin No	Wire Color	Assigned function
1	White	OSSD2
2	–	(Not in use)
3	Black	OSSD1
4	Yellow	<b>Muting input 1</b>
5	Orange	Synchronization 1 (RS485_+)
6	Orange/Black	Synchronization 2 (RS485_-)
7	Blue	0 V
8	Red	<b>Muted condition output</b>
9	Red/Black	EDM input
10	Brown	+24 V
11	Pink	<b>Muting input 2</b>
12	Grey	FE

**Reference**

When "Assign Muting input to receiver" is selected on the configuration software, the muting related inputs are not available on the transmitter. Accordingly, the 11-core cable cannot be used for the transmitter.



## ■ When "Apply muting bank" is selected.

☞ "(1) Muting" (page 6-17)

Transmitter: 11-core cable

Pin No	Wire Color	Assigned function
1	White	<b>Muting bank input 1</b>
2	–	(Not in use)
3	Black	Error output
4	Yellow	<b>Muting bank input 2</b>
5	Orange	Synchronization 1 (RS485_+)
6	Orange/Black	Synchronization 2 (RS485_-)
7	Blue	0 V
8	Red	Muting lamp output
9	Red/Black	Muting input 2
10	Brown	+24 V
11	Pink	Muting input 1
12	Grey	FE

Receiver: 11-core cable

Pin No	Wire Color	Assigned function
1	White	OSSD2
2	–	(Not in use)
3	Black	OSSD1
4	Yellow	RESET input
5	Orange	Synchronization 1 (RS485_+)
6	Orange/Black	Synchronization 2 (RS485_-)
7	Blue	0 V
8	Red	AUX (auxiliary) output
9	Red/Black	EDM input
10	Brown	+24 V
11	Pink	<b>Muting bank input 3</b>
12	Grey	FE

## ● When "Built-in indicator mode" is selected.

☞ "Display setting (Center indicator)" (page 6-22)

Transmitter: 11-core cable

Pin No	Wire Color	Assigned function
1	White	<b>Built-in indicator input red</b>
2	–	(Not in use)
3	Black	Error output
4	Yellow	<b>Built-in indicator input green</b>
5	Orange	Synchronization 1 (RS485_+)
6	Orange/Black	Synchronization 2 (RS485_-)
7	Blue	0 V
8	Red	Muting lamp output
9	Red/Black	Muting input 2
10	Brown	+24 V
11	Pink	Muting input 1
12	Grey	FE

Receiver: 11-core cable

Pin No	Wire Color	Assigned function
1	White	OSSD2
2	–	(Not in use)
3	Black	OSSD1
4	Yellow	RESET input
5	Orange	Synchronization 1 (RS485_+)
6	Orange/Black	Synchronization 2 (RS485_-)
7	Blue	0 V
8	Red	AUX (auxiliary) output
9	Red/Black	EDM input
10	Brown	+24 V
11	Pink	<b>Interlock selection input</b>
12	Grey	FE

### Reference

- The Error output and AUX output function can be changed to other non safety-related output function through the configuration software.  
Detail information for the output functions, see ☞ "Non Safety-Related Outputs" (page 2-36).
- When "Built-in indicator mode" is selected on the configuration software, the synchronization 1 and 2 must be connected between the transmitter and receiver. The built-in indicator mode cannot be available in optical synchronization system.
- The 7-core cable can be used for the receiver.

# 4-4 Cable Specification

(1) Cable length

1. Optical synchronization system and wire synchronization system

The sum of the length for the unit connection cable and extension cable must be 30 m or less. This limitation applies separately to the entire transmitter cable setup and the entire receiver cable setup. There is no limitation for the total length of series connection cables when the GL-R is connected in series.

2. One-line system

The sum of the length for all of the unit connection cables, extension cables and series connection cables must be 30 m or less.

	<ul style="list-style-type: none"><li>• Cables must be within the lengths specified. Failure to follow this specification may cause improper operation of safety functions, and may create a dangerous situation.</li><li>• The series connection cable cannot be cut or extended. If the cable is cut or extended, safety features may not operate properly. Do not allow this to happen as it is extremely dangerous.</li></ul>
---	---

(2) Minimum cable bending radius : 5 mm

(3) Identification of connector cables

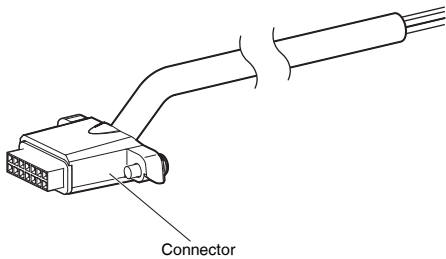

Connector colors

PNP output type cables or series connection cables : Black connectors

NPN output type cables : Grey connectors

 Point	<p><b>PNP output type cables and NPN output type cables cannot be used at the same time (mixed wiring is not possible). One type of cable must be chosen based on the application.</b></p>
---	--

## NOTICE

- If any input or output wires remain open (completely disconnected), they must be capped.
- The functions assigned to the input and output may differ according to the configuration when configuring through the configuration software.  
 "Cable Color and Pin Position" (page 4-4)

## Symbols

- R1, R2 : External device (Safety PLC, Safety relay unit, etc)  
 K1, K2 : External device (Force guided relay, magnet contactor, etc)  
 K3 : Solid state contactor<sup>\*1</sup>  
 S1 : Switch used for reset input  
 S2 : Switch used for wait input<sup>\*1</sup>  
 S3 : Switch used for override input  
 S4, S5, S6 : Switch used for muting bank inputs  
 L1 : Muting lamp (Incandescent lamp or LED lamp)  
 P1, P2 : Muting device (Self-contained photoelectric sensors, etc.)  
 M : 3-phase motor  
 PLC : For NON SAFETY-RELATED system control use<sup>\*1</sup>

\*1 These are NON SAFETY-RELATED components

## Reference

- Grey wire (FE) is electrically-connected to the light curtain body case.
- The light curtain body case and internal power signal lines are coupled by capacitor (3 kV, 100 pF).

## Optical synchronization system

- Transmitter: 5-core cable, Receiver: 5-core cable

(1) PNP output cable

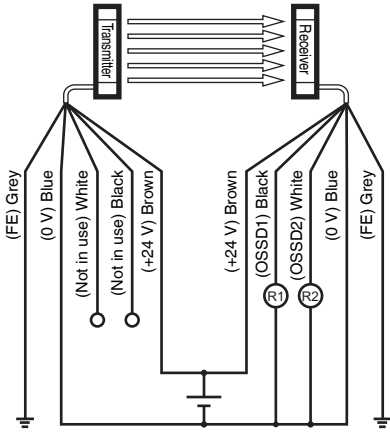

Reference

The transmitter and receiver can operate on individual power supply in optical synchronization system.

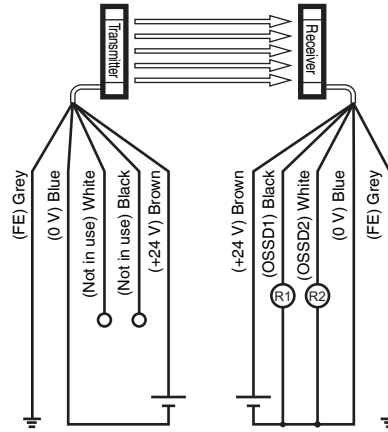

(2) NPN output cable

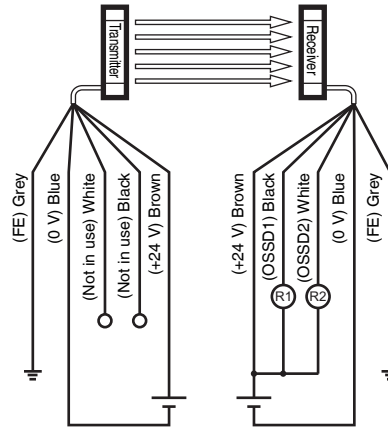
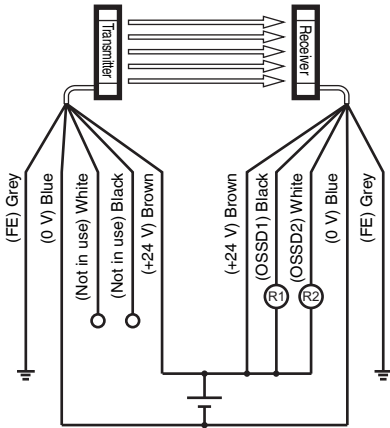

● **Transmitter: 5-core cable, Receiver: 11-core cable,  
When using the EDM function and interlock function**

(1) PNP output cable

Reference

The transmitter and receiver can operate on individual power supply in optical synchronization system.

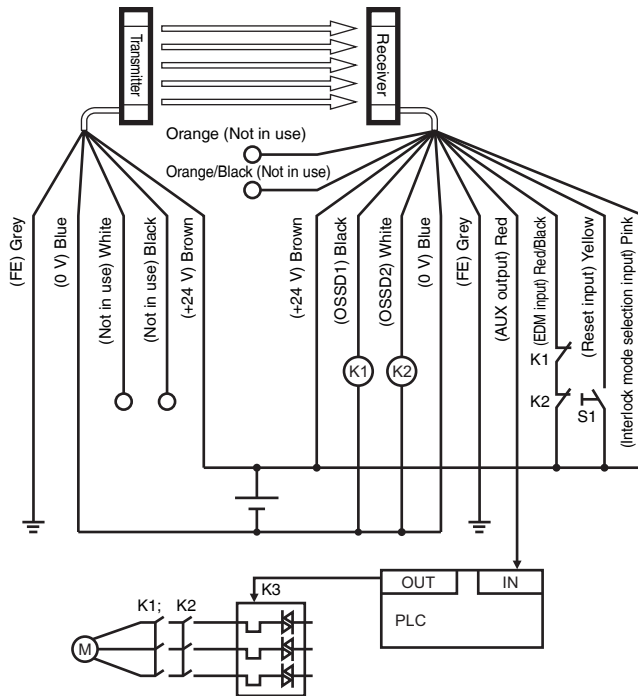

(2) NPN output cable

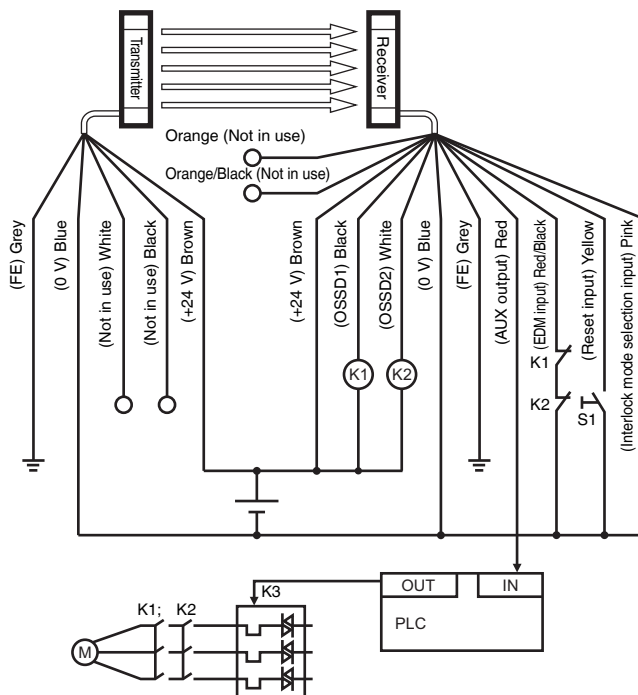

■ When the muting input function is assigned on the receiver cable.

Reference

- The 11-core cable cannot be used for the transmitter.
- If the 5-core cable is used for the transmitter, the GL-R operates by optical synchronization system.

● Transmitter: 5-core cable, Receiver: 11-core cable

When not using the EDM function and using the interlock function

(1) PNP output cable

Reference

The transmitter and receiver can operate on individual power supply in optical synchronization system.

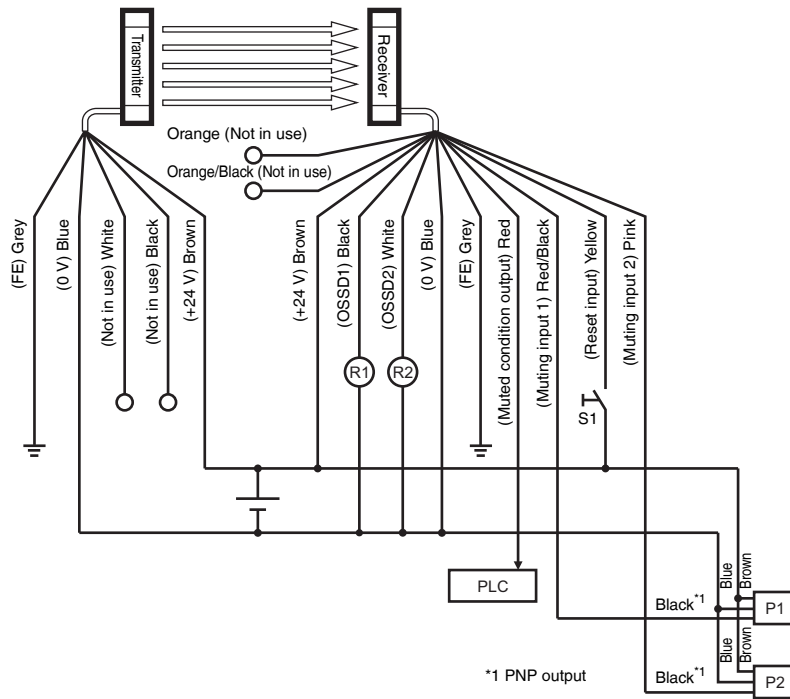

(2) NPN output cable

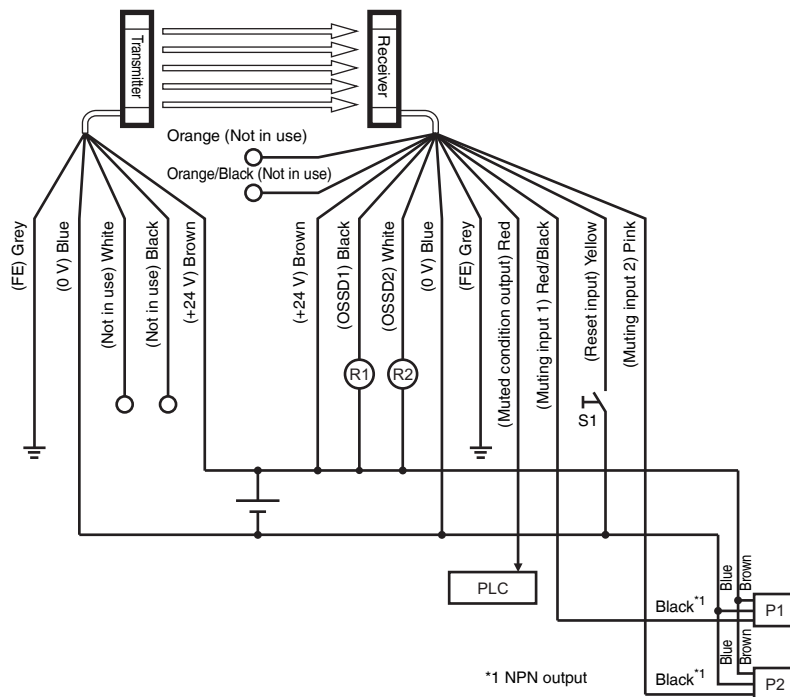

● **Transmitter: 5-core cable, Receiver: 11-core cable**  
**When using the EDM function and not using the interlock function**

(1) PNP output cable

**Reference**

The transmitter and receiver can operate on individual power supply in optical synchronization system.

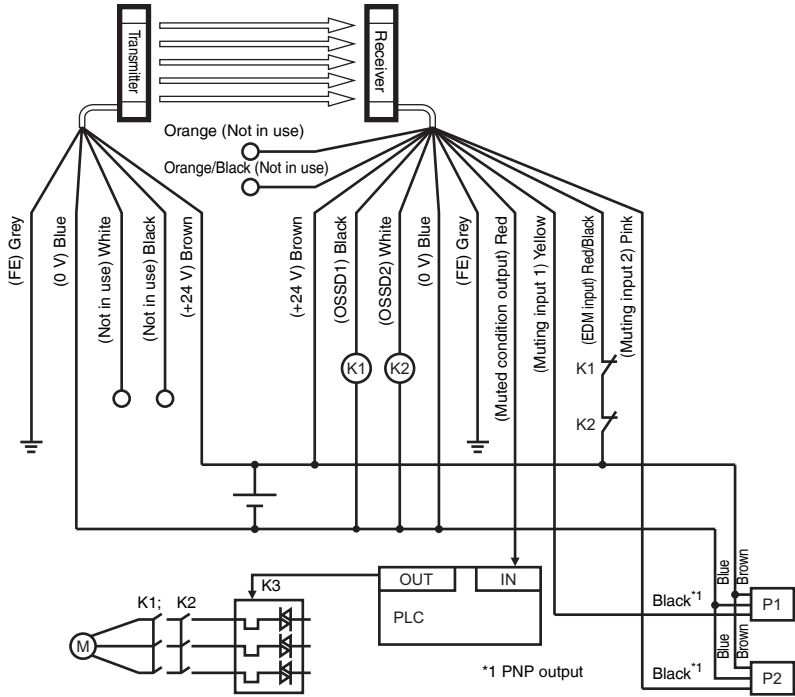

(2) NPN output cable

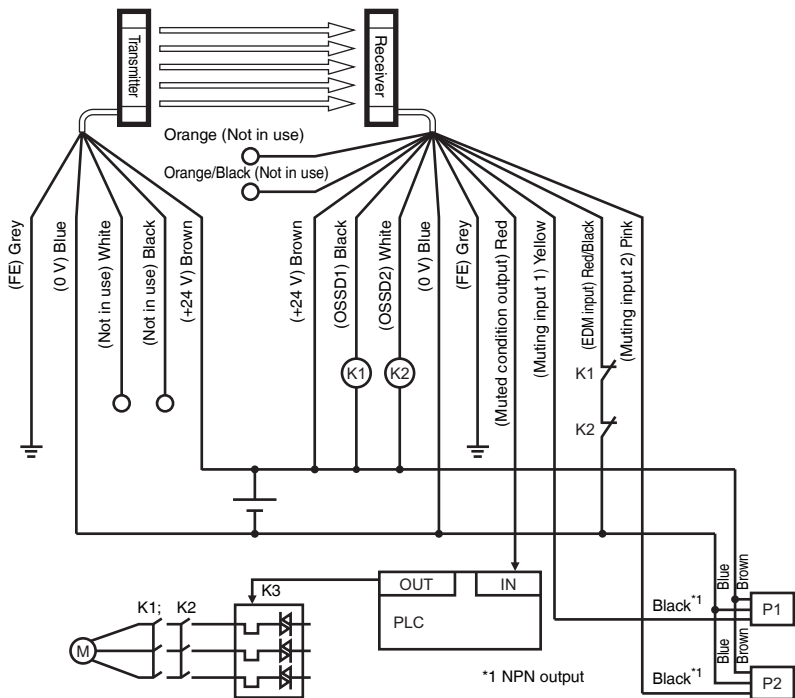

## One-line system

- Transmitter: Series connection cable, Receiver: 5-core cable

(1) PNP output cable

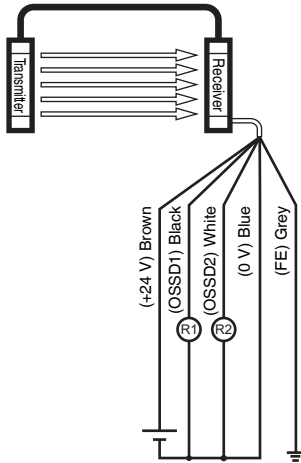

(2) NPN output cable

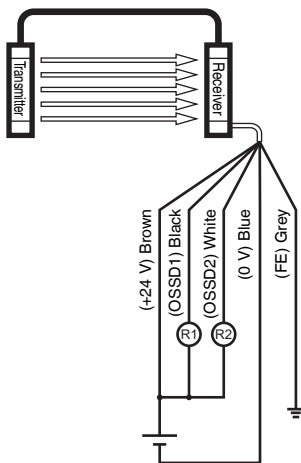



● **Transmitter: Series connection cable, Receiver: 11-core cable**

When using the EDM function and interlock function

(1) PNP output cable

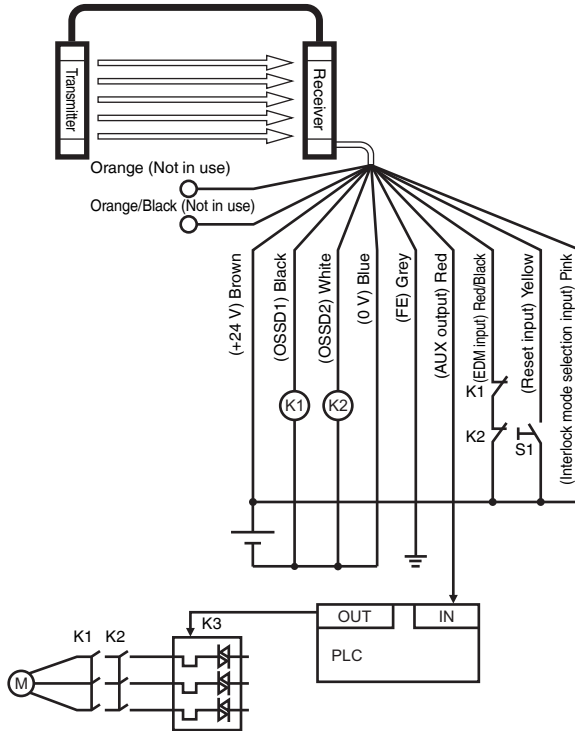

(2) NPN output cable

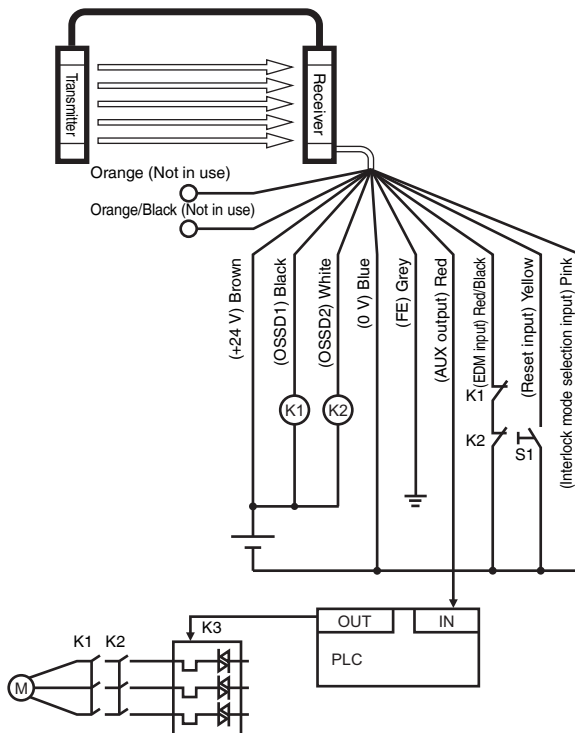

## Wire synchronization system

**Reference**

Different core number cables can be used for the transmitter and receiver at the same time. For example, using the 11-core cable for the transmitter and 7-core cable for the receiver.

● **Transmitter: 7-core cable, Receiver: 7-core cable**

(1) PNP output cable

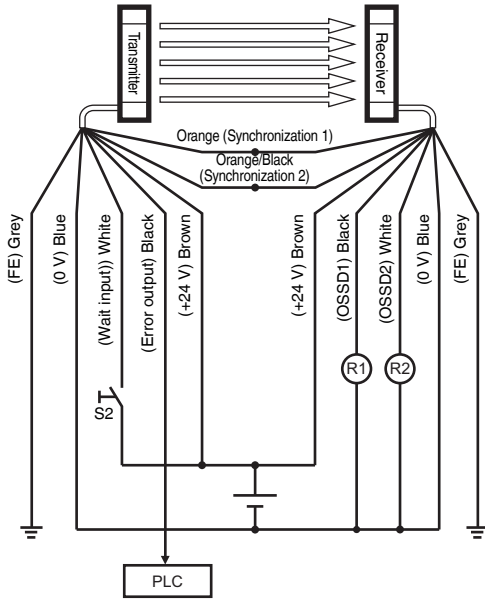

(2) NPN output cable

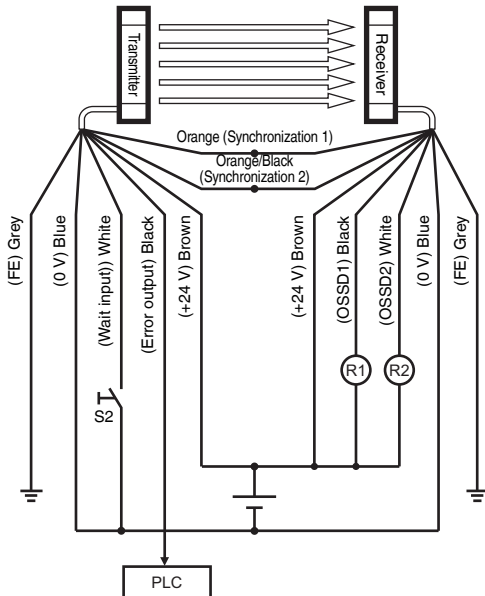

● **Transmitter: 11-core cable, Receiver: 11-core cable**  
**When using the EDM function and interlock function**

(1) PNP output cable

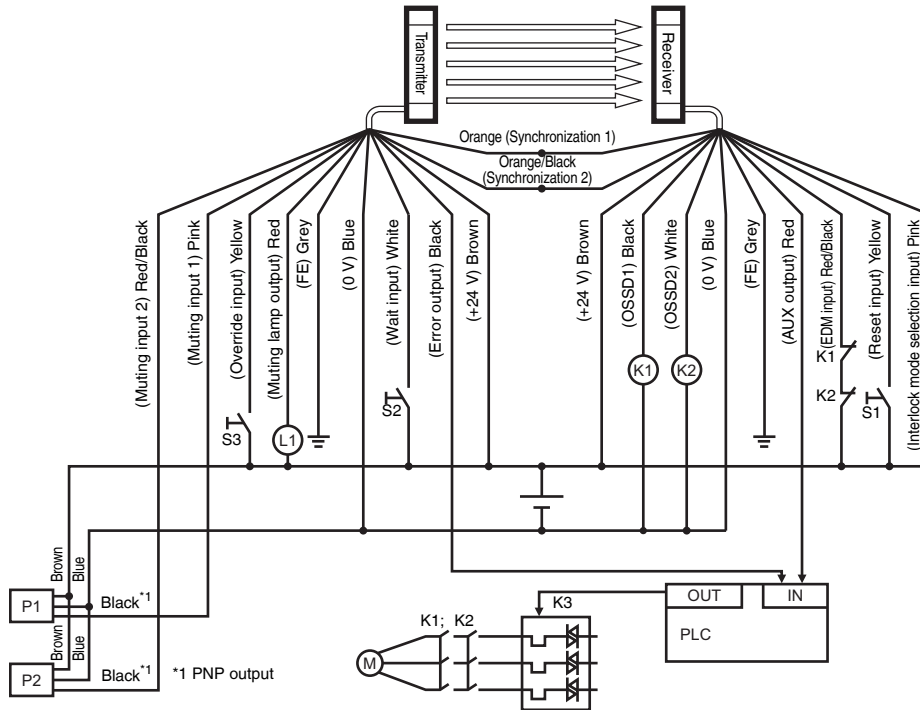

(2) NPN output cable

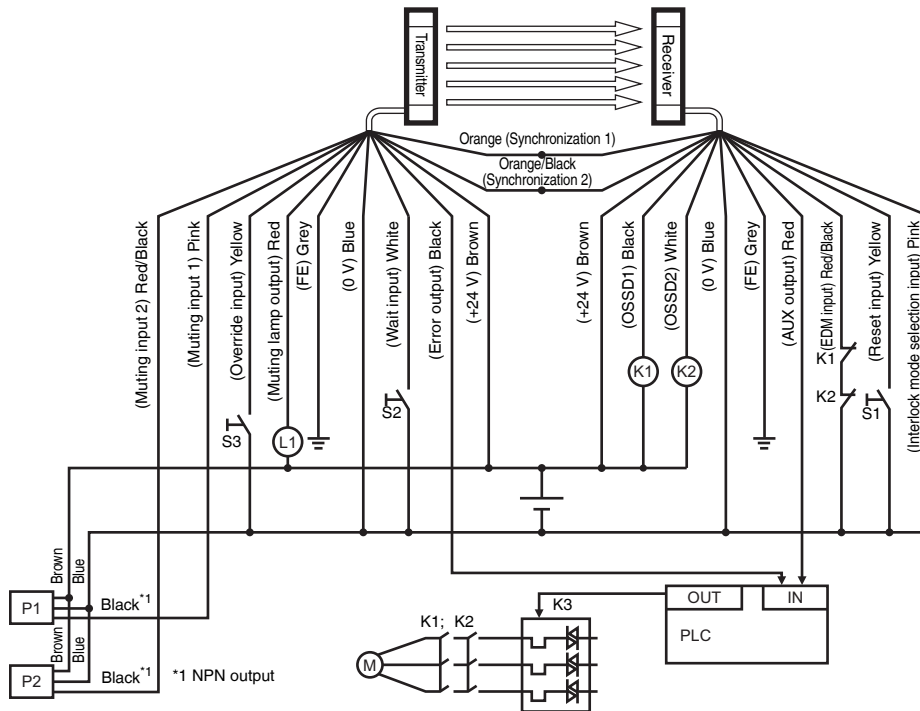

● Transmitter: 11-core cable, Receiver: 11-core cable  
When not using the EDM function or interlock function

(1) PNP output cable

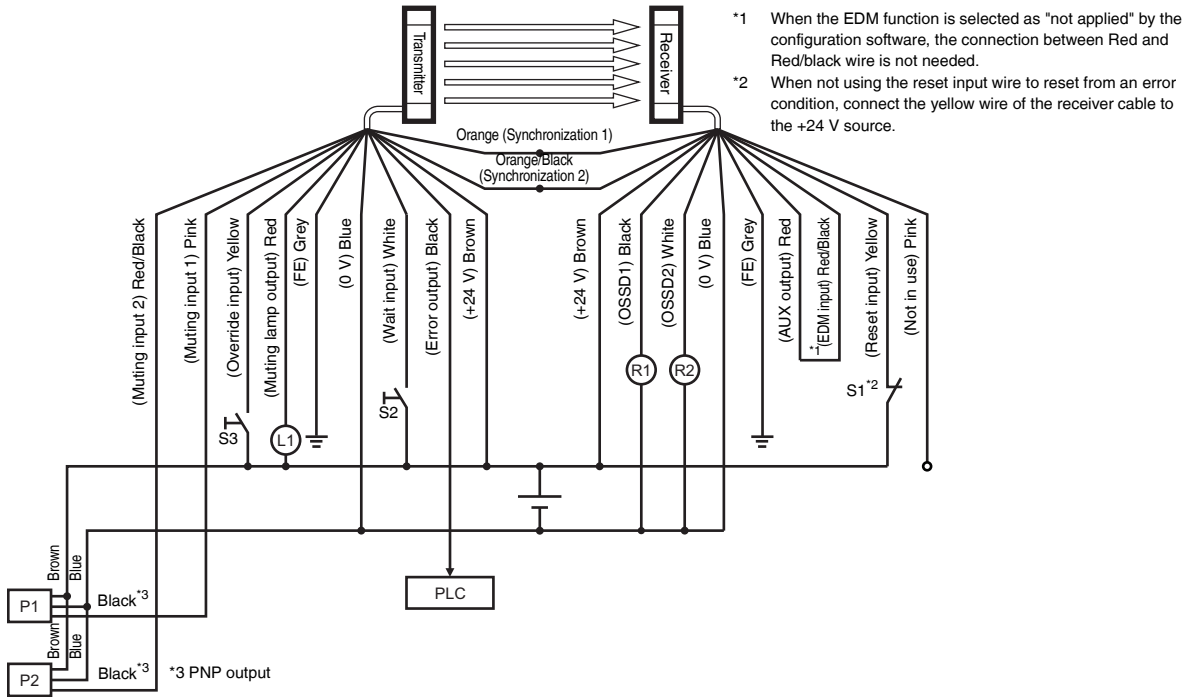

(2) NPN output cable

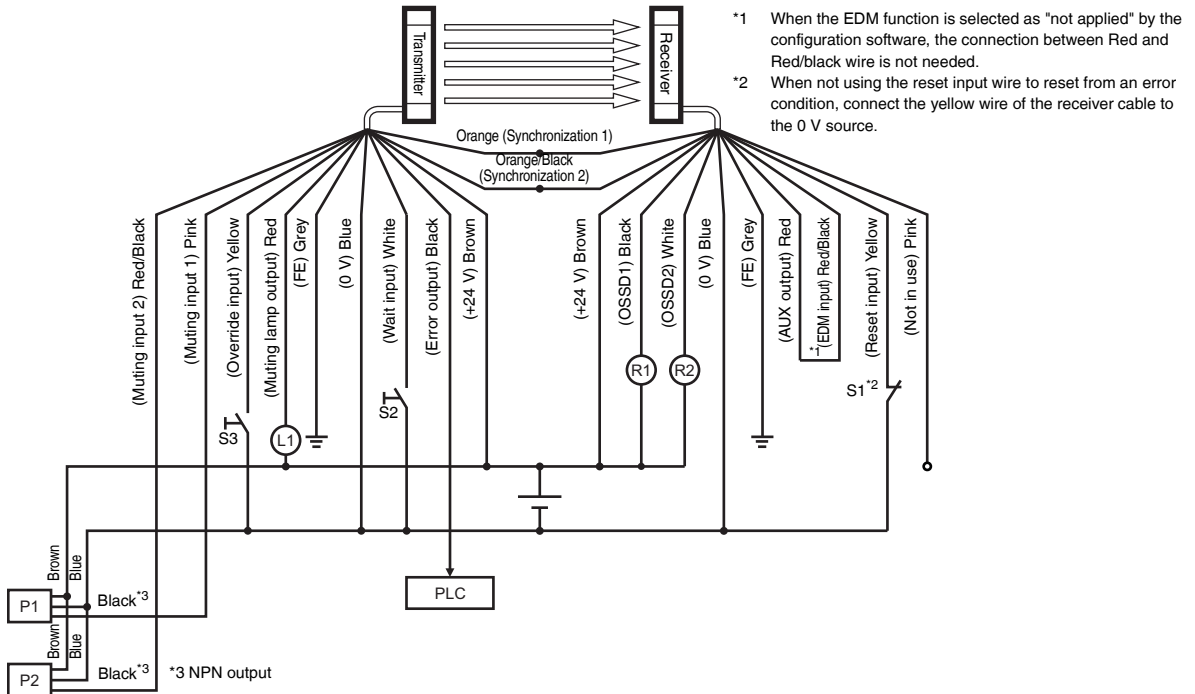

■ When using the muting bank function.

- Transmitter: 11-core cable, Receiver: 11-core cable

When using the EDM function and interlock function

(1) PNP output cable

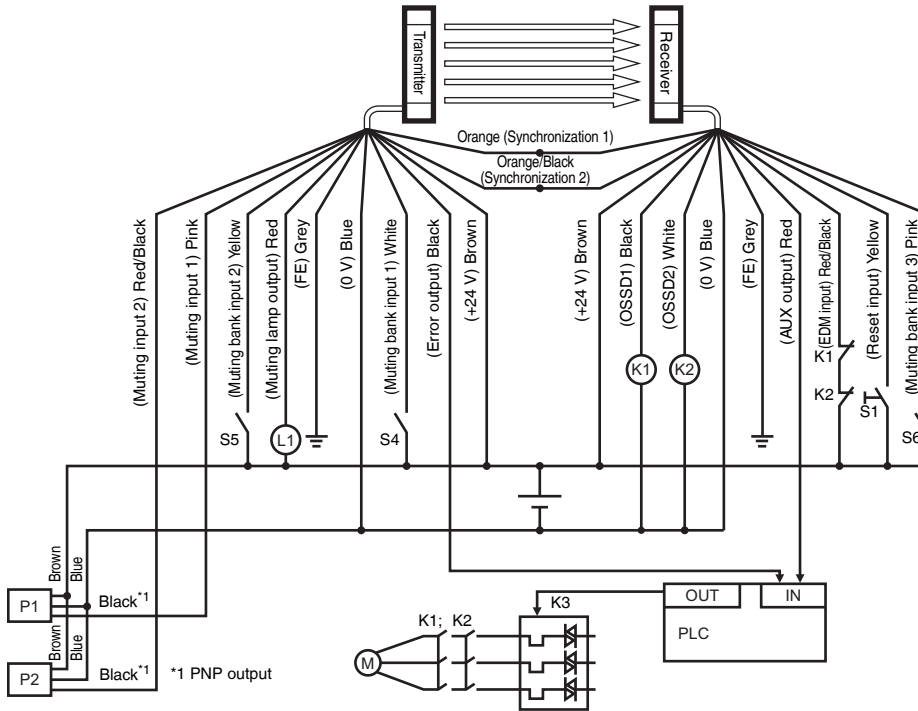

(2) NPN output cable

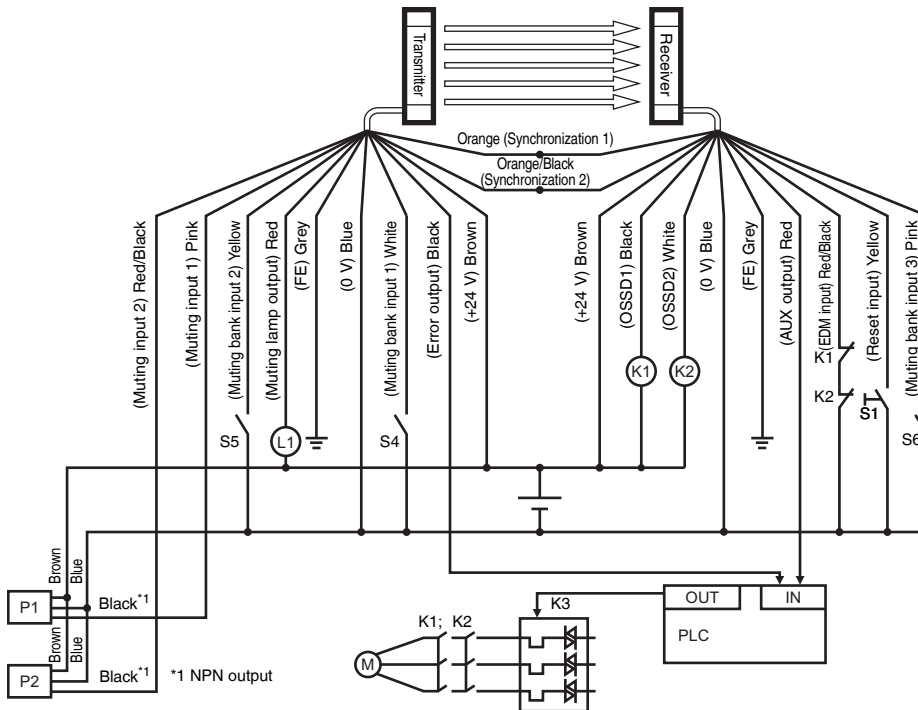

● Transmitter: 11-core cable, Receiver: 11-core cable  
When not using the EDM function and interlock function

(1) PNP output cable

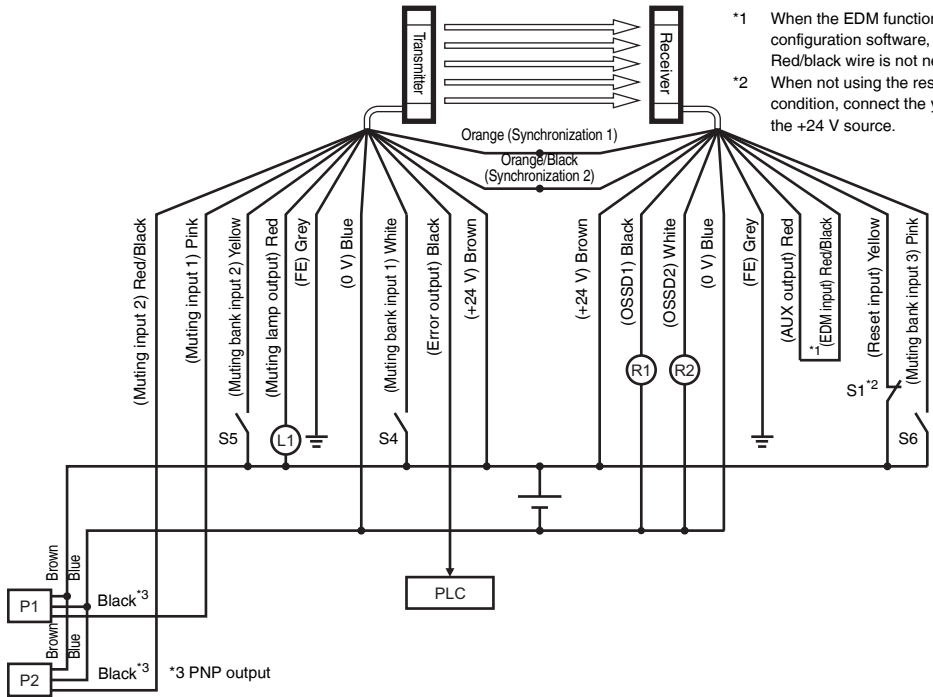

- \*1 When the EDM function is selected as "not applied" by the configuration software, the connection between Red and Red/black wire is not needed.
- \*2 When not using the reset input wire to reset from an error condition, connect the yellow wire of the receiver cable to the +24 V source.

(2) NPN output cable

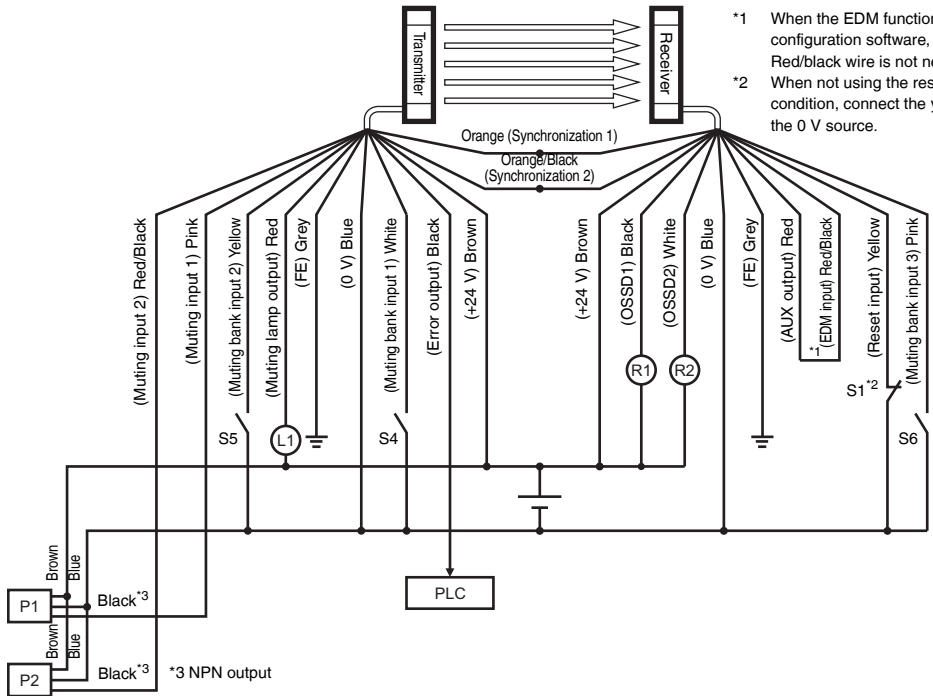

- \*1 When the EDM function is selected as "not applied" by the configuration software, the connection between Red and Red/black wire is not needed.
- \*2 When not using the reset input wire to reset from an error condition, connect the yellow wire of the receiver cable to the 0 V source.

# 5

## Indicators

---

---

5-1	Function Indicators and 7-segment Display . . . . .	5-2
5-2	Center Indicator . . . . .	5-4

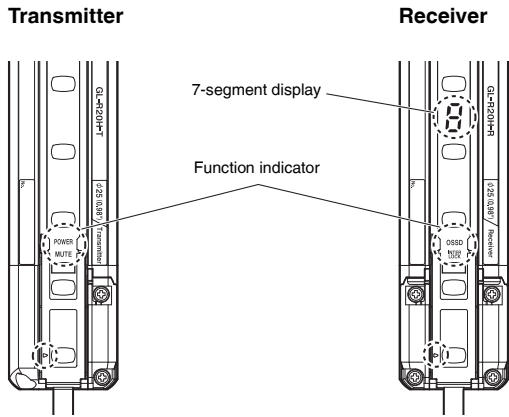

## Function indicators

Transmitter		
Name	Indicator	Description
POWER (Orange)	Light ON	Power ON (Transmitter)
	Light OFF	Power OFF (Transmitter)
MUTE (Orange)	Light ON	Muted condition or Override condition
	Blinking slowly	Muting input 1 ON
	Blinking	Muting input 2 ON or Muting input 1 ON and Muting input 2 ON
	Light OFF	Muting input 1 OFF and Muting input 2 OFF

Receiver		
Name	Indicator	Description
OSSD (Red/Green)	Light in red	OSSD OFF
	Light in green	OSSD ON
	Blinking in green	Amount of received light is unstable. (Alert output OFF)
	Light OFF	Power OFF (Receiver)
INTERLOCK (Yellow)	Light ON	Interlock condition
	Blinking	Interlock reset ready condition (Interlock reset ready output ON)
	Light OFF	No interlock or error condition

\* When optical synchronization system is applied, only the "POWER" indicator turns ON on the transmitter. "Wiring System" (page 2-2)

"Alert output" (page 2-39)





"Interlock reset ready output" (page 2-40)









## 7-segment display

### ■ Upon power-up

The segment LEDs light up in the following sequence during start-up according to the synchronization between the transmitter and receiver (approx. 2.5 seconds or less).

Wire synchronization system or one-line system	Optical synchronization system		
	Channel 0	Channel A	Channel B
			

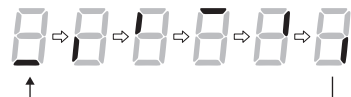
### ■ During normal operation (other than error condition)

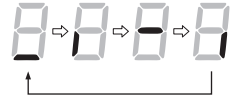
Condition		Display
Applying the reduced resolution function or fixed blanking function.		
Wait input is activated.		
Applying the muting function or override function.	Muting input 1 is activated.	
	Muting input 2 is activated.	
	Muting input 1 and 2 are both activated* <sup>1</sup> .	
	Muted condition	
	Override input is activated* <sup>2</sup> .	
	Override condition.	
Other than those above.		Turn OFF

\*1 When not in the muted condition because conditions for initiation of muting are not met.

\*2 When not in the override condition because conditions for initiation of override are not met.

### ■ During error condition

The segment LEDs indicate the error number.

☞ "Troubleshooting" (page A-2)

☞ "OSSD" (page 2-6)

#### Reference

When multiple GL-R conditions overlap simultaneously, the indication is according to the following priority.

1. Error condition
2. Power up
3. Override input
4. Wait input
5. Muting input 2
6. Muting input 1
7. Reduced resolution or fixed blanking function

# 5-2 Center Indicator

## Overview

Center indicators are present on both the transmitters and receivers.

### ■ GL-RF

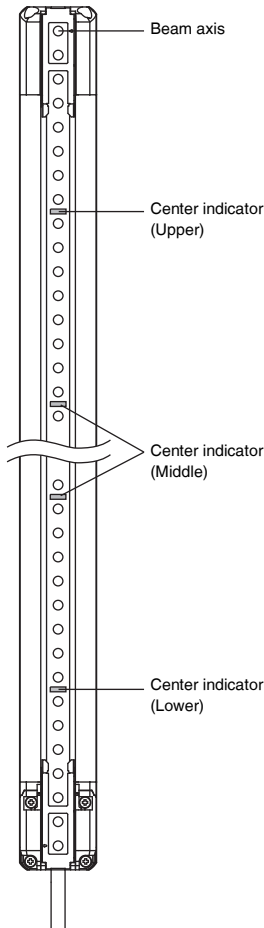

### ■ GL-RH

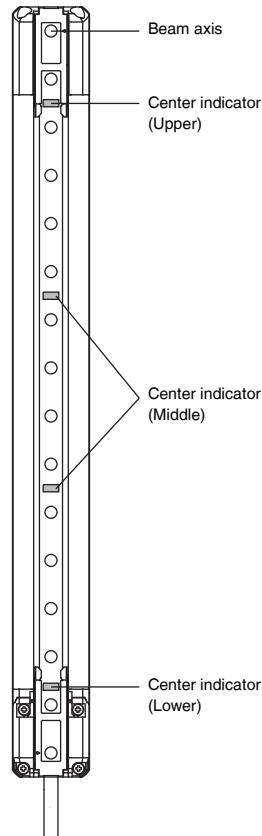

$$\text{Number of center indicators} = (\text{Number of beam axis}) / 4$$

### ■ GL-RL

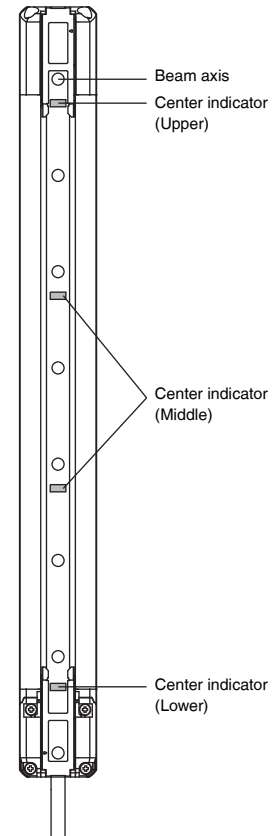

$$\text{Number of center indicators} = (\text{Number of beam axis}) / 2$$

$$\text{Number of center indicators} = (\text{Number of beam axis} + 1) / 8 - 1$$

Center indicator	Light OFF	red light	green light	Blinking red light
Upper	Top beam axis is blocked	Although the top beam axis is unblocked, the others are blocked	No interruption is present in detection zone of the GL-R. (clear)	Error condition
Middle	Top beam axis or bottom beam axis is blocked	Although the top and bottom beam axis are unblocked, the middle beams are blocked		
Lower	Bottom beam axis is blocked	Although the bottom beam axis is unblocked, the others are blocked		

#### Reference

- When the GL-R operates in optical synchronization system, the center indicators on the transmitter light OFF.
- In the case of series connection, the indicators on each unit indicate independently according to their condition. □ "Series connection" (page 2-3)
- Applying the fixed blanking function to a beam reverses the clear and blocked status for that beam. □ "Fixed Blanking" (page 2-31)

## Changing the Indication Method for the Center indicator

The indication method for the center indicator can be changed via setting switch on the GL-R receiver or through, the configuration software for the GL-R. Four options are possible, but differences exist between the setting switch and configuration software.

📖 "Chapter 6 Setting Method Using the Configuration Software" (page 6-1)

📖 "1-2 Part Description" (page 1-10)

(○: Setting possible –: Setting not possible)

Item	Settable Item	
	Setting switch on the GL-R receiver	Configuration software
Green Light OFF	○	○
OFF	–	○
Built-in indicator mode	–	○
State indicator mode	–	○

### ■ Green Light OFF

The center indicator is OFF when no interruption is present in detection zone of the GL-R (clear).

The center indicator lights up or blinks in red when the OSSD is in the OFF state or the GL-R is in error condition.

### ■ OFF (deactivation of the center indicator)

The center indicator is always OFF.

### ■ Built-in indicator mode

This mode is available when the GL-R operates in wire synchronization system.

The 11-core cable must be used for both the transmitter and receiver.

The center indicator can be controlled externally by input signal from the unit connection cable.

The indication methods are as follows. The white and yellow input wires are found in the cable connected to the transmitter.

Red light: The white wire is activated.

Green light: The yellow wire is activated.

Light OFF: Both the white and yellow wires are not activated.

\* When both the white and yellow wires are activated, the indicator lights in green.

### ■ State indicator mode

The center indicator lights or blinks to indicate the state of the GL-R based on previously-set conditions.

The following indicator state assignments are possible.

(✓: Setting possible –: Setting not possible)

GL-R state	Indicator state			
	Light OFF	Light in red	Blinking in green	Light in green
Waiting (Wait input ON)	✓	✓	✓	–
Ready for interlock reset (Interlock-reset-ready output ON)	✓	✓	✓	✓
OSSD OFF	✓	✓	–	–
Muting / Override (Muted condition output ON)	✓	–	✓	–
Alert (Alert output OFF)	✓	–	✓	✓
OSSD ON	✓	–	–	✓

When multiple GL-R conditions overlap simultaneously, the upper conditions of the above table have priority.

MEMO

# 6

## Setting Method Using the Configuration Software

---

---

6-1	Before Use .....	6-2
6-2	Installing the configuration software.....	6-3
6-3	Connecting the GL-R Main Unit and PC .....	6-5
6-4	Main Screen Part Names.....	6-7
6-5	Starting and Exiting the GL-R Configurator .....	6-9
6-6	Login/Logout .....	6-12
6-7	Uploading the Configuration Data .....	6-13
6-8	Saving the Configuration Data .....	6-15
6-9	Configuration Tab .....	6-16
6-10	Monitor Tab .....	6-23
6-11	Other Functions.....	6-27

# 6-1 Before Use

## About the configuration software

The configuration software <Safety Device Configurator> integrates the safety device configuration software made by KEYENCE. The <Safety Device Configurator> consists of the following four software applications.

- Safety light curtain GL-R Series configuration software <GL-R Configurator>.
- Safety light curtain SL-V configuration software <SL-V Configurator>.
- Safety laser scanner SZ-V configuration software <SZ-V Configurator>.
- Safety laser scanner SZ configuration software <SZ Configurator>

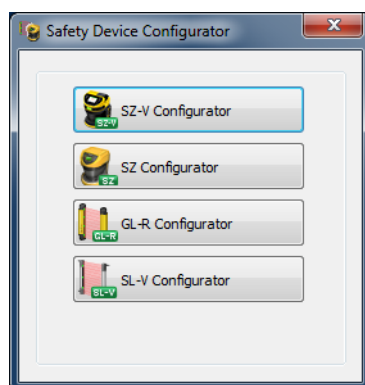

- Configuration data can be made on PC even if the GL-R main unit is not connected.
- Configuration data can be sent if there is a receiver of the GL-R main unit. (Receiver of the main unit if serial connection has been made.)
- When monitoring the operation status, connect the transmitter and receiver.

## System Requirements

To use the configuration software, the following system requirements must be met.

CPU	Pentium 4 1.5 GHz or more
Compatible OS <sup>*1</sup>	Windows XP (SP3 or later versions) Windows 7 Windows 8 Windows 8.1 Windows 10
Memory capacity	512 MB or more
Hard disk free space	500 MB or more
Communication interface	USB 1.1 or more
Display	XGA (1024×768) or greater, 256 colors or greater (High Color or better recommended)
Operating condition	.NET Framework 4.0 or 4.5 has been installed. <sup>*2</sup>

\* Confirm system requirements of each OS separately.

\*1 Windows XP support only the 32 bit type.

The OS supports Japanese, English, German, Italian, French, Spanish and Simplified Chinese.

\*2 If ".NET Framework 4.0" has not been installed on the PC, ".NET Framework 4.0" will be automatically installed when this software is installed.

The following conditions must be satisfied to install ".NET Framework 4.0."

- Hard disk space: 1.2 GB or more just for .NET Framework 4.0 (For 64-bit platform: 2.1 GB or more)
- Windows Installer 3.1 or later versions has been installed.
- Internet Explorer 5.01 or later versions has been installed.

This section describes how to install the configuration software.

## Before Installation

Check the following before installation.



Point

Backing up the data is recommended in case of accidents such CD-ROM damage, etc.

### ■ Free space on the hard disk

The configuration software can be installed only on a hard disk drive. 500 MB of hard disk space at the installation destination are necessary. (1.2 GB are necessary for a PC onto which .NET Framework 4.0 has not been installed. (For 64-bit platform: 2.1 GB or more)) If the hard disk space is insufficient, secure the space beforehand.

### ■ Pre-installation Windows environment

The configuration software operates on Windows and it is installed on Windows. Ensure that Windows XP/7/8/8.1/10 is installed on the computer and is working properly.

### ■ USB port

To send configuration data from a PC to the GL-R Series or to use the monitor function via a USB port, ensure the USB port of the PC is ready to use. For the setting method, refer to the operation manual of your PC.

### ■ Help file

The help file for the configuration software has been created in PDF file format. Install Adobe Systems' Adobe Reader to view this manual.

You can download the latest version of the Adobe Reader for free from the Adobe Systems Incorporated web site: (<http://www.adobe.com>).

## Downloading the configuration Software

The configuration software can be downloaded from KEYENCE homepage.

<http://www.keyence.com>

If using in the environment where downloading software is not possible via the internet, contact your nearest KEYENCE office or distributor.

## Installation Procedure

Execute "setup.exe" stored in the downloaded file.

After that, start installation according to the instruction of the installation program.

When installation ends successfully, the following five software applications are installed.

- Integrated software <Safety Device Configurator>.
- GL-R configuration software <GL-R Configurator>.
- SL-V configuration software <SL-V Configurator>.
- SZ-V configuration software <SZ-V Configurator>.
- SZ configuration software <SZ Configurator>.



Point

**Log on as a user having Administrator authority.**

## Uninstalling each software

Use "Add or Remove Programs" on the Control Panel of Windows to uninstall each software.



Point

**Log on as a user having Administrator authority.**

## Note for Windows 7/8/8.1/10

If the "User Account Control" screen appears during installation or uninstallation, click "Continue (C)".



**! Point**

- To connect the GL-R main unit to the PC, the optional interface unit GL-R1UB and the [A : miniB] type of USB cable are necessary.  
 "Software and Interface Unit" (page 1-9)
- Only one interface unit can be connected to one computer.

## Part Names

### ■ Interface unit GL-R1UB

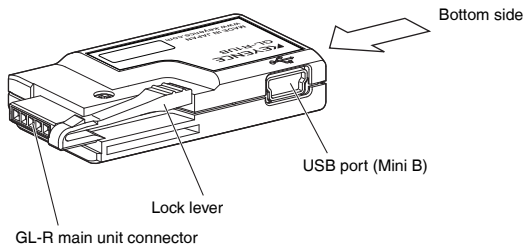

### ■ GL-R receiver lower side

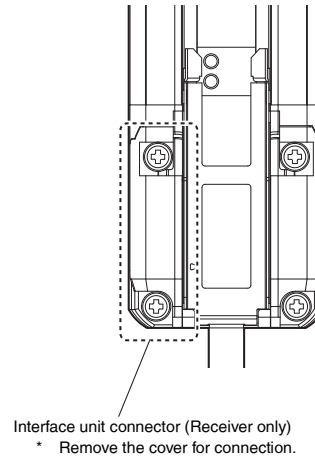

### ● Bottom side

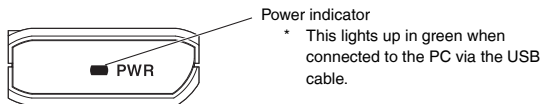

## Connection Method



- Do not remove the black packing attached to the connector cover. If this packing is removed, the protection structure IP65/67 rating cannot be guaranteed.
- Tighten the screw of the connector cover securely with the recommended tightening torque. If the recommended tightening torque is not achieved, IP67 cannot be guaranteed.

**1** Loosen the screws on the cover of the GL-R receiver's interface port and remove it.

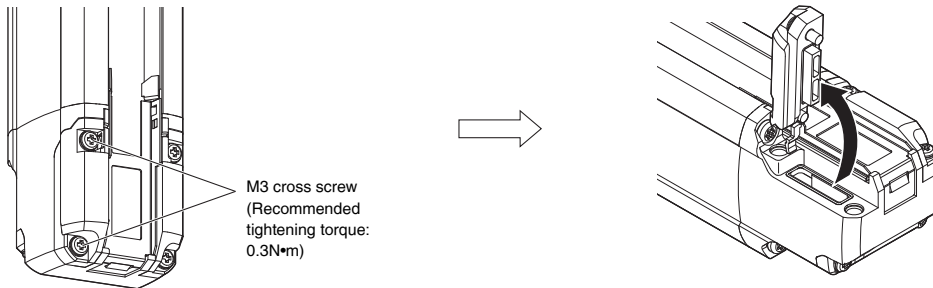

**2** Connect the interface unit to the receiver of the GL-R main unit. Insert it until the lock lever clicks.

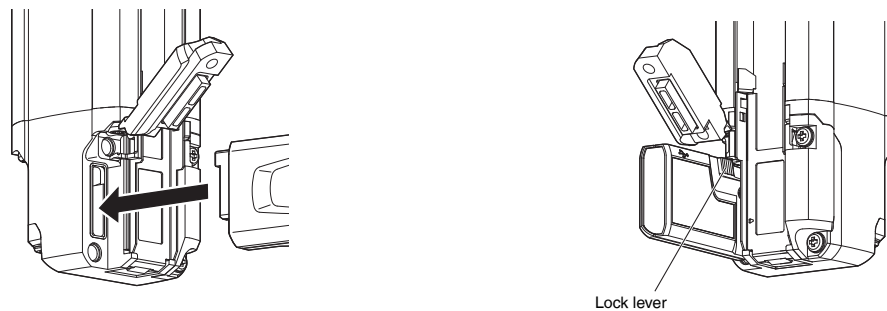

**3** Connect the USB cable to the interface unit and to the USB port of PC.

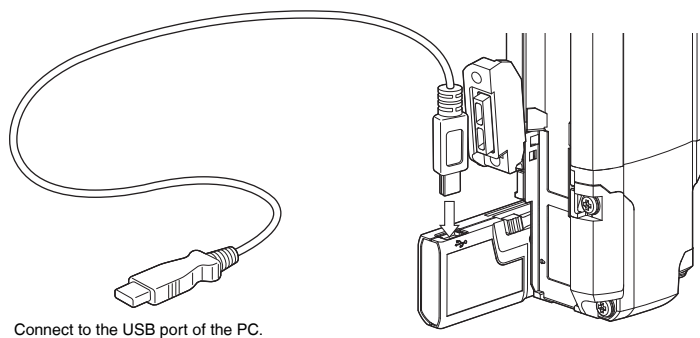

**4** When the setting is complete, hold down the lock lever and pull out the interface unit. Finally, make sure to tighten the M3 screws on the port cover. (Recommended tightening torque: 0.3N•m)

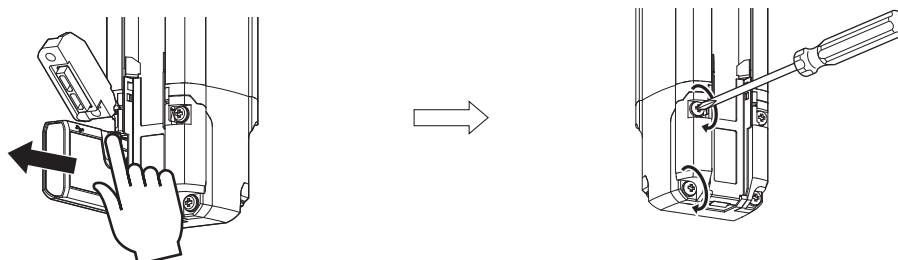

# 6-4 Main Screen Part Names

This section describes the part names and functions of the main screen.

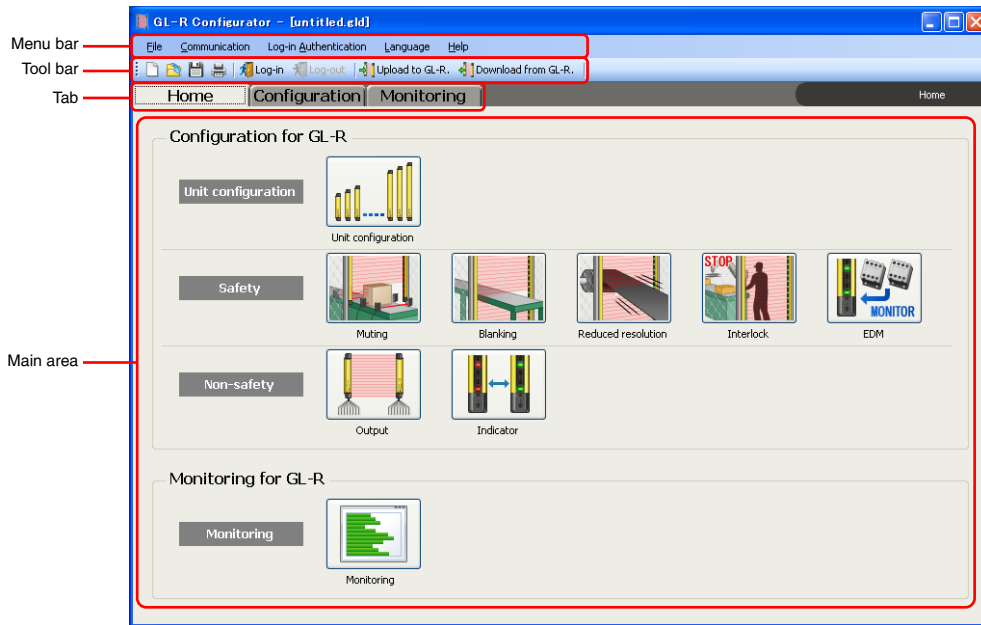

## Menu bar

This bar indicates the functions available within the software.

## Tool bar

This bar contains frequently used functions.

Icon	Description
	Create a new configuration file. ☞ "When "Create a new configuration file" is selected" (page 6-10)
	Read out the created configuration file. ☞ "When reading the created configuration files" (page 6-11)
	Overwrite and save the contents being configured. ☞ "6-8 Saving the Configuration Data" (page 6-15)
	Print the contents being configured.
	To upload the configuration data to the GL-R main unit, connect the GL-R main unit and login. ☞ "6-6 Login/Logout" (page 6-12)
	Upload the configuration data to the connected GL-R main unit. ☞ "6-7 Uploading the Configuration Data" (page 6-13)
	Download the configuration data from the connected GL-R main unit. ☞ "When "Download a configuration file from GL-R" is selected" (page 6-9)

## Tab

Click the tab to switch the items that can be set in the main area.

Item	Description
Home tab	Initial screen where each function setting, monitor and usable functions are easily viewed. Clicking an image illustration can switch the main area.
Configuration tab	The main area is switched to the screen where the settings for safety function and non-safety function can be made. ☞ "6-9 Configuration Tab" (page 6-16)
Monitor tab	The main area is switched to the monitor screen. ☞ "6-10 Monitor Tab" (page 6-23)

## Main area

Create settings or monitor in this area. Displayed items are switched according to the selected tab.

# 6-5 Starting and Exiting the GL-R Configurator

## Starting the <GL-R Configurator>

Start the <GL-R Configurator> according to the following procedure.



Point

Only one <GL-R Configurator> window can be run at a time.

- 1 Double-click the [KEYENCE Safety Device Configurator] shortcut icon on the desktop. If the icon is not present on the desktop, select [All Programs (or Programs)] → [Safety Device Configurator] or [GL-R Configurator] in [Keyence Applications].

Double-clicking the shortcut icon will display the Configurator selection screen.

Select [GL-R Configurator]. If the powered-on GL-R main unit is connected via USB, this item is skipped.

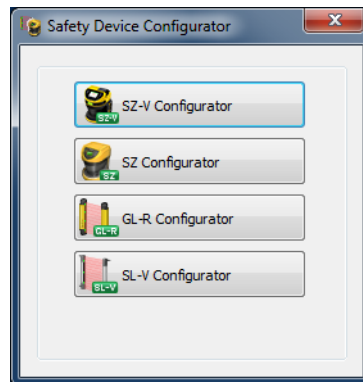

- 2 The GL-R Configurator starts with the main selection screen.

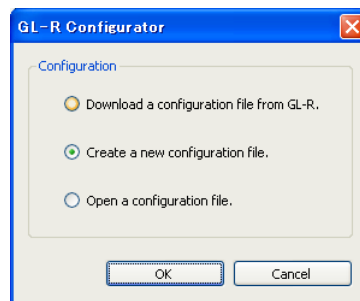

- 3 Select the desired software mode and click the [OK] button.

### ■ When "Download a configuration file from GL-R" is selected

When [Download a configuration file from GL-R.] is selected, the configuration from the connected GL-R main unit is downloaded and the software starts.



Point

- Before selecting [Download a configuration file from GL-R] and clicking the [OK] button, confirm that the PC and the GL-R main unit are properly connected with the USB cable.
- Confirm that the GL-R main unit is turned on.
- If the communication is aborted before downloading is complete, the configuration is not reflected in the software. Click the [Download] button on the tool bar to read again, or create a new configuration.

■ When "Create a new configuration file" is selected

When "Create a new configuration file" is selected, the [Unit configuration] dialog box appears.

When entering the model information for configuration, the GL-R configurator starts with the default value for each setting.

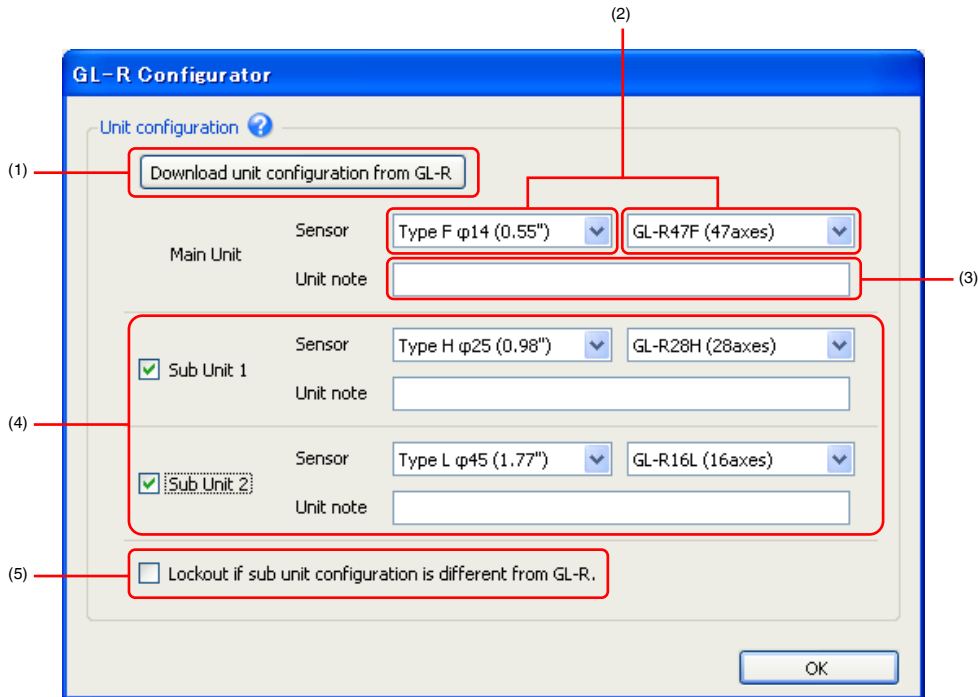

Item	Description
(1) Download unit configuration from GL-R.	Download the configuration of the connected GL-R main unit. (The existing model and settings previously entered will be discarded and replaced with the downloaded information.)
(2) Main unit model	Select the minimum detectable object size and model (number of beam axes) of the main unit.
(3) Unit note	A note can be added to each unit. (Up to 10 double-byte characters, and 20 single-byte characters.)
(4) Sub unit	For serial connection, select the checkbox and enter the sub unit information. (Up to 20 characters regardless of double-byte character or single-byte character) ☐ "Series connection" (page 2-3)
(5) Error if sub unit configuration is different from GL-R.	The number of beam axes of the Sub Unit 1 and Sub Unit 2 can be memorized in the GL-R main unit. If the configurations are sent with this option selected and if the added sub unit has a different number of beam axes from the number set on the GL-R Configurator, the configurator enters an error state and cannot start.

**Reference** The contents set here can be changed from the [Unit configuration] screen on the configuration tab later.  
☐ "Unit configuration" (page 6-16)

## ■ When reading the created configuration files

When "Open a configuration file." is selected, the [Open] dialog box appears.

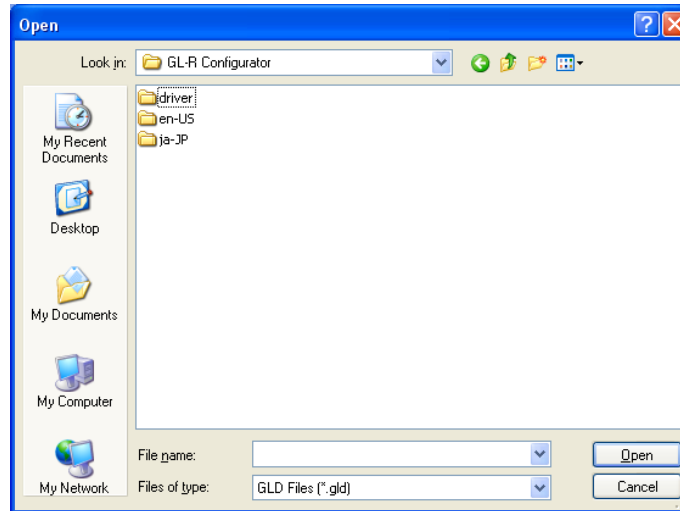

Selecting the <GL-R Configurator> file (\*.gld) and clicking the [Open] button will open the configuration file.

## Exiting the <GL-R Configurator>

To exit the <GL-R Configurator>, select [File] → [Exit] on the menu.

If the configuration contents have been changed, the confirmation dialog box is displayed to confirm if the changed settings should be saved or not.

### ! Point

**When saving the configuration settings, click [Yes] to save the configuration file. If the [No] button is clicked, the configuration contents are not saved and will be discarded.**

# 6-6 Login/Logout

To upload the configuration data to the GL-R main unit, connect the GL-R main unit and login.



Point

Login is only possible when the GL-R main unit is connected. "Connection Method" (page 6-6)

## Login



### 1 Click the [Login] button on the tool bar.

The [Password entry] dialog box appears.

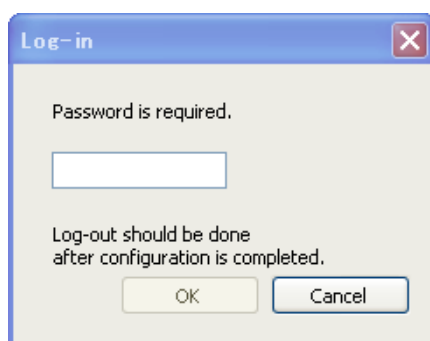

### 2 Enter the 4-digit numeric password and click the [Login] button.

The dialog box is closed and the [Login] button is grayed out.

Reference

- Password default: "0000"
- Change the password from the default value.
- ☐ "Changing the password" (page 6-29)
- ☐ "If you forget the password" (page 6-29)



Point

If a communication error occurs during login, it will automatically logout. When this occurs, check the connection status and login again.

## Logout



Press the [Logout] button on the tool bar.

The [Logout] button is grayed out after logout.



Configuration data created on the GL-R Configurator can be transferred to the GL-R main unit.

 <b>DANGER</b>	<b>When the receiver of main unit is replaced, make sure to upload the configuration data again.</b>
---	--

 **Point**

- When the model configuration of the sub unit is changed after the configuration is transferred, the GL-R main unit may not start (Error occurs.), depending on the setting. In this case, set the model configuration and upload the data again.
- Login is necessary to upload the configuration data.  
 "6-6 Login/Logout" (page 6-12)
- If the main unit configuration model [Unit configuration] differs from the connected GL-R main unit, the configuration data cannot be uploaded.
- Even if the sub unit configuration model [Unit configuration] differs from the connected GL-R main unit, the configuration data can be uploaded.



**1** Click the [Upload to GL-R] button on the tool bar.

 **Point**

When the configuration data is uploaded, the original configuration in the GL-R main unit is replaced. Click the [Download from GL-R] button on the tool bar as necessary to, download the configuration and save it.

 "6-8 Saving the Configuration Data" (page 6-15)

The [Confirmation] dialog box appears.

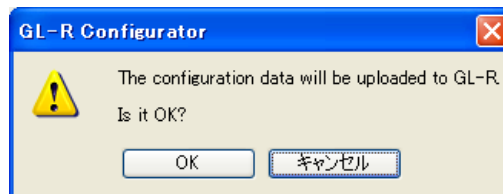

**2** Click the [OK] button.

The first page of the [Upload] dialog box appears.

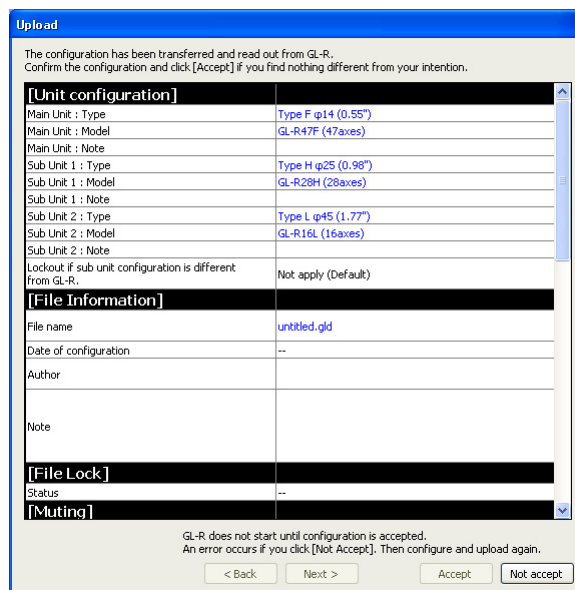

[Unit configuration]	
Main Unit : Type	Type F φ14 (0.55")
Main Unit : Model	GL-R47F (47axes)
Main Unit : Note	
Sub Unit 1 : Type	Type H φ25 (0.98")
Sub Unit 1 : Model	GL-R28H (28axes)
Sub Unit 1 : Note	
Sub Unit 2 : Type	Type L φ45 (1.77")
Sub Unit 2 : Model	GL-R16L (16axes)
Sub Unit 2 : Note	
Lockout if sub unit configuration is different from GL-R.	Not apply (Default)
[File Information]	
File name	untitled.gld
Date of configuration	--
Author	
Note	
[File Lock]	
Status	--
[Muting]	
Status	--

GL-R does not start until configuration is accepted.  
An error occurs if you click [Not Accept]. Then configure and upload again.

**3** Scroll down the scroll bar and confirm all the settings. Then, Click the [Next >] button or [Accept] button.

**! Point**

Make sure to confirm the configuration contents being uploaded and click the [Accept] button. If unintended configurations are displayed, click the [Not accept] button. When the [Not accept] button is clicked, the configuration data is not transferred to the GL-R main unit and it will not start (enters the error state). To restore to the normal state, an upload must be completed once.

● **When the muting and fixed blanking functions are not used**

Click the [Accept] button. If the [Accept] button is grayed out and cannot be clicked, operate the scroll bar to display all configurations.

The configuration data will be reflected in the GL-R main unit.

● **When the muting or fixed blanking functions are used**

Click the [Next >] button. If the [Next >] button is grayed out and cannot be clicked, operate the scroll bar to display all configurations.

The second page of the [Upload] dialog box appears.

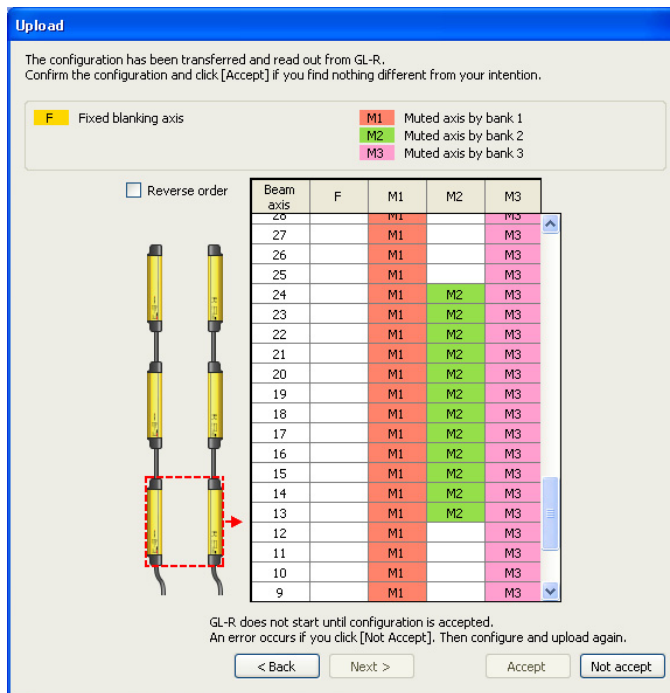

Click the [Accept] button. If the [Accept] button is grayed out and cannot be clicked, operate the scroll bar to display all configurations.

The configuration data will be reflected in the GL-R main unit.

# 6-8 Saving the Configuration Data

Created configuration contents can be saved on the PC. Saved configurations can be loaded later.

## Saving the configuration data

- 1 From the menu, select [File (F)] → [Save as (A)].

The [Save As] dialog box appears.

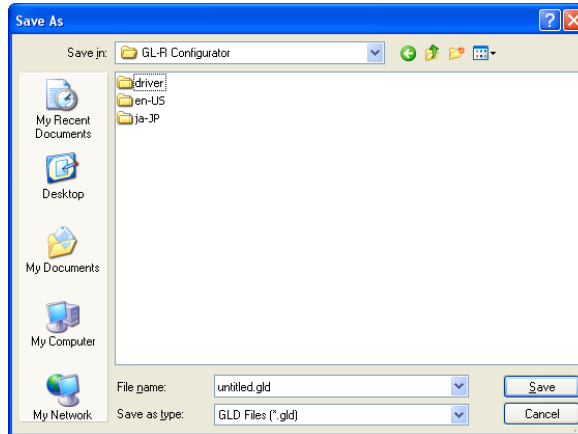

- 2 Enter the file name, and click the [Save (S)] button.

The configuration file is saved at the location specified for [Save in].

## Opening the saved configuration

- 1 From the menu, select [File (F)] → [Open (O)]. Or click the [Open] button on the tool bar.

The [Open] dialog box appears.

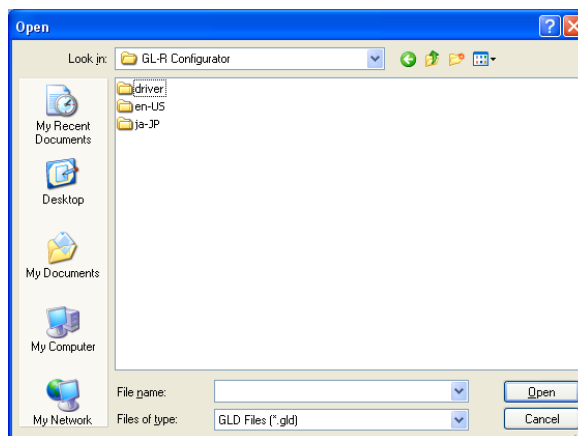

- 2 Select the saved file and click the [Open (O)] button.

The selected configuration is loaded.

If the configuration contents have been changed, the confirmation dialog box is displayed to confirm if the changed settings should be saved or not.

### ! Point

When saving the configuration contents, click [Yes] to save the configuration file. If the [No] button is clicked, the configuration contents are not saved and are discarded.

# 6-9 Configuration Tab

Clicking the function button in the sub panel will change the color of the function button to blue. Each setting can be made on the main panel.

The [Upload] button functions in the same way as the [Upload to GL-R] button on the tool bar.

☞ "6-7 Uploading the Configuration Data" (page 6-13)

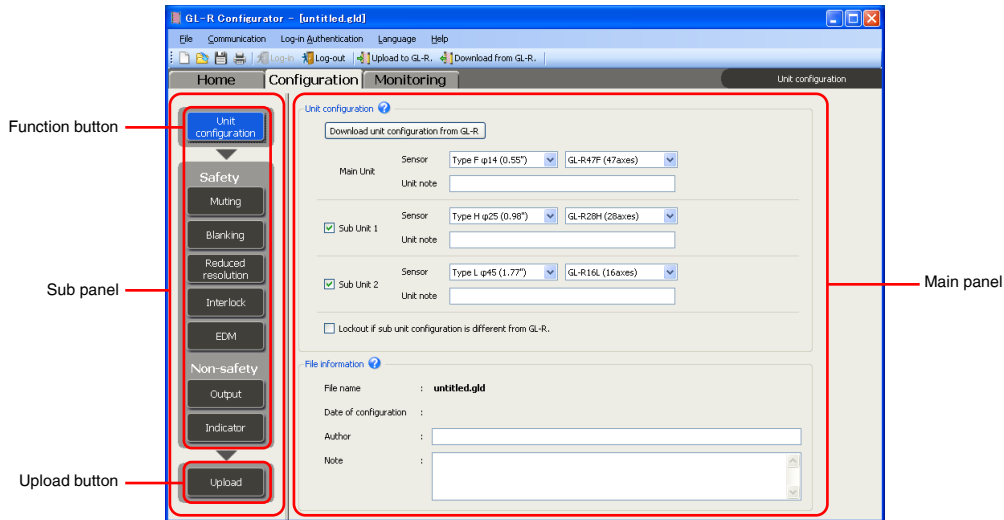

**Reference**

When the pointer is moved closer to the ? mark, additional explanations are displayed.

## Unit configuration

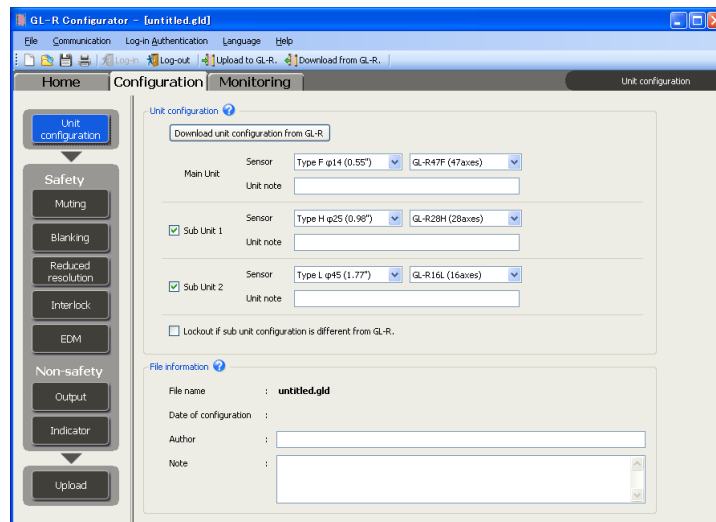

Item	Description
Unit configuration	☞ "When "Create a new configuration file" is selected" (page 6-10)
File information	This displays information regarding the GL-R main unit configurations.
File name	The name of the configuration file is displayed. New, unsaved files are displayed as "untitled.gld".
Date of configuration	This displays the date when the configuration data was saved or updated from GL-R Configurator to GL-R main unit. This is loaded from the main unit and displayed when the configuration file is uploaded to the GL-R main unit or the configuration file is downloaded from the GL-R main unit. If any of the configurations is changed, this is not displayed.
Author	Enter information such as a name of person in charge of the configuration. Up to 32 characters can be input regardless of double-byte character or single byte character.
Note	Enter comments. Up to 100 characters can be input. Line feed is possible for comments. 2 characters are assigned for a line feed.

## Safety function

For more information about functions that can be set, see ["Chapter 2 Functions and Features"](#) (page 2-1).

### Muting

["Temporary Suspension of Safety Function"](#) (page 2-13)

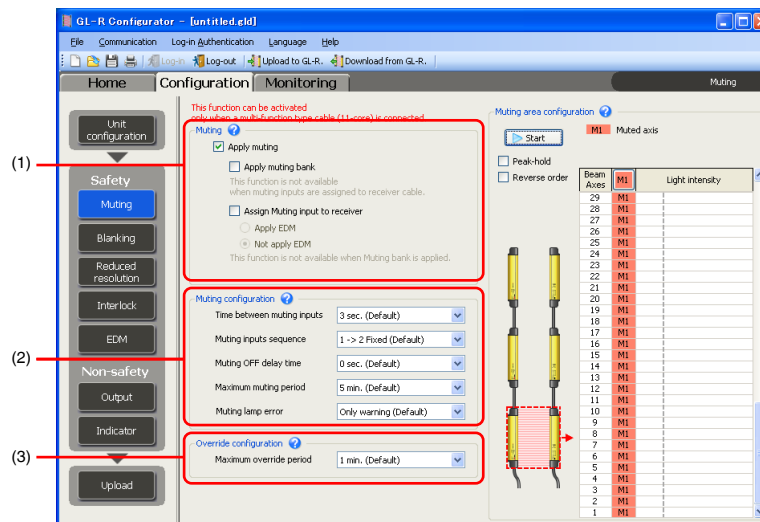

#### (1) Muting

Item	Configuration content	Description
Apply muting	ON (Default)/OFF	Select whether to use the muting function.
Apply muting bank	ON/OFF (Default)	Select whether to use the muting bank function.
Assign Muting input to receiver	ON/OFF (Default)	The muting input is normally assigned to the transmitter. Set whether to assign the muting input to the receiver. Reference <input type="checkbox"/>

#### (2) Muting configuration

Item	Configuration content	Description
Time between muting inputs*	1 sec./3 sec. (Default)/ 10 sec./30 sec./Not specified	Set the maximum timing between Muting input 1 and Muting input 2. (The minimum time of 0.04 sec. cannot be changed.)
Muting input sequence	Input 1→Input 2: Fixed sequence (Default)/ Not specified	Set the sequence order for Muting input 1 and Muting input 2 to activate muting (ON).
Muting OFF delay time	0 sec. (Default)/4 sec.	Select the delay time until the muting state is canceled after either Muting input is turned OFF.
Maximum muting period*	1 min./5 min. (Default)/ 10 min./20 min./Not specified	Set the maximum muting duration.
Muting lamp error	Only warning (Default)	When muting lamp failure is detected, error will not occur.
	Error	When muting lamp failure is detected, error will occur.

\* When the time between muting inputs is set to longer than "3 seconds (Default)", the maximum muting period is set to "Not specified" and the input time difference between Muting input 1 and Muting input 2 exceeds 3 seconds, then the maximum muting period will be limited to approx. 5 minutes.

(3) Override configuration

Item	Configuration content	Description
Maximum override period	30 sec./1 min. (Default)/ 5 min./15 min.	Set the maximum override duration.

● Muting area configuration

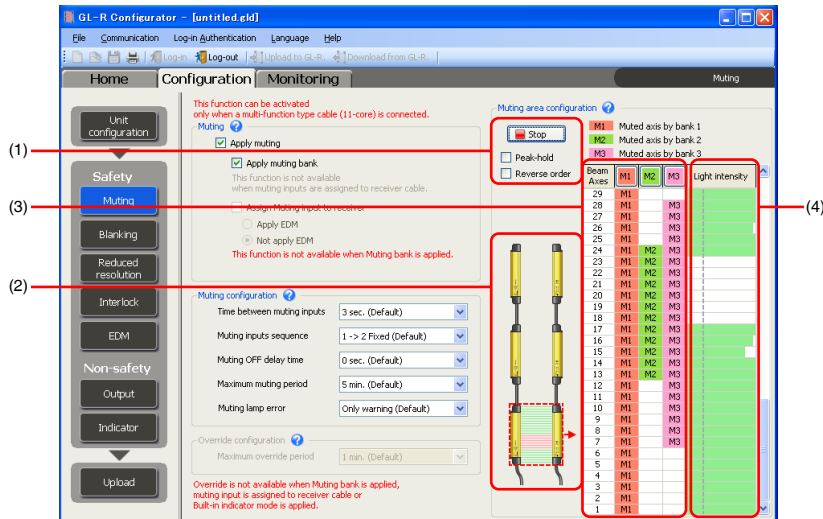

Item	Description	
(1)	Start/Stop	This starts or stops monitoring the amount of received light that the GL-R main unit connected to the PC receives.
	Peak-hold	When the checkbox is ON <input checked="" type="checkbox"/> , the line indicating the peak value for the amount of received light is displayed in the [Amount of received light monitoring area].
	Reverse order	When the checkbox is ON <input checked="" type="checkbox"/> , the main unit is displayed as the top unit in the image.
(2)	Unit display	When serial connection is made, this shows which unit is set.
(3)	Configuration area	Specify the beam axis to be muted in the <M1> column.<M2> & <M3> can be specified when the muting bank function is used. Beam axes with a blank display are not activated for muting. Each time the columns for <M1>, <M2>, or <M3> are clicked, Applied/Not applied is switched. The settings can be switched for all beams at once by dragging down through the column.
(4)	Amount of received light monitoring area	Displays the amount of received light on the bar graph. As the bar extends to the right, the amount of received light increases. The color of the bar is green for light received and pink for light blocked. (When the fixed blanking function is applied, the colors for the beam axes are reversed.)

☐ "Availability of functions which can be configured by the configuration software" (page 2-5)

## ■ Blanking

📖 "Fixed Blanking" (page 2-31)

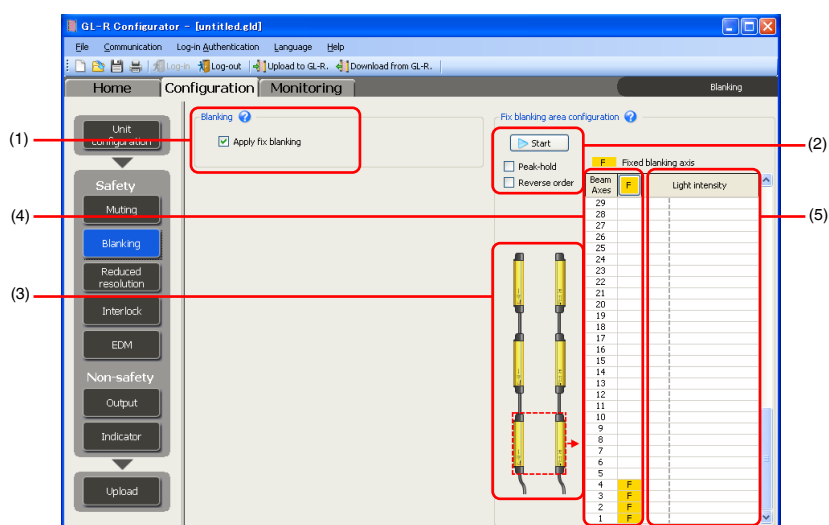

Item	Description
(1) Blanking	When the check box is ON <input checked="" type="checkbox"/> , the fixed blanking function can be activated. The default value is OFF.
(2) Start/Stop	This starts or stops monitoring the amount of received light that the GL-R main unit connected to the PC receives.
(2) Peak-hold	When the checkbox is ON <input checked="" type="checkbox"/> , the line indicating the peak value for the amount of received light is displayed in the [Amount of received light monitoring area].
(2) Reverse order	When the checkbox is ON <input checked="" type="checkbox"/> , the main unit is displayed as the top unit in the image.
(3) Unit display	When serial connection is made, this shows which unit is set.
(4) Configuration area	Specify the beam axis to apply fixed blanking in the <F> column. The fix blanking function is not applied for beam axes with a blank display. (Example: It is not applied for beam axes from No. 11 to 20 in the above figure.) Each time the <F> column is clicked, Apply/Not apply is switched. The settings can be switched for all beams at once by dragging down through the column.
(5) Amount of received light monitoring area	Displays the amount of received light on the bar graph. As the bar extends to the right, the amount of received light increases. The color of the bar is green for light received and pink for light blocked. (When the fixed blanking function is applied, the colors for the beam axes are reversed.)

■ Reduced resolution

📖 "Reduced Resolution" (page 2-32)

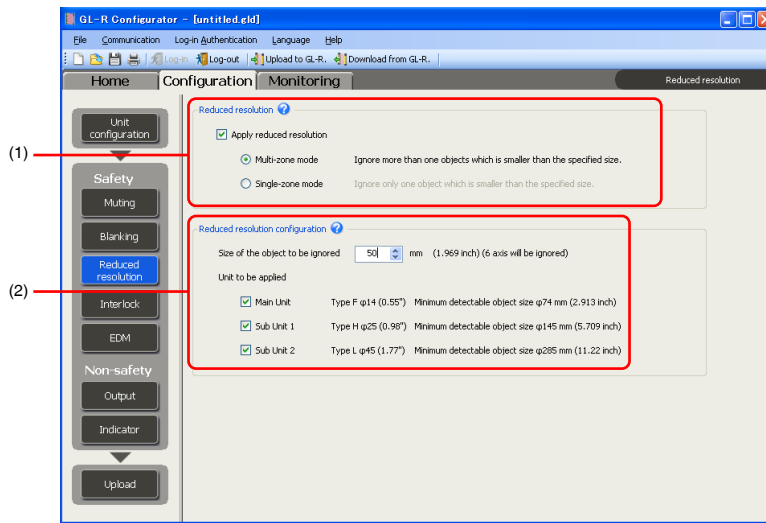

Item		Description
(1)	Reduced resolution	When the check box is ON <input checked="" type="checkbox"/> , the reduced resolution function can be activated. The default value is OFF.
	Multi-zone mode/Single-zone mode	Select the desired mode. 📖 "2-8 Reduced Resolution" (page 2-32)
(2)	Size of the object to be ignored	Enter the size of the object to be ignored within the range of 1 mm to the size of the protection zone. Entering the size will automatically set the number of beam axes to be ignored.
	Unit to be applied	The reduced resolution function is applied to the unit(s) for which the checkboxes are selected as ON <input checked="" type="checkbox"/> . If serial connection performed, the checkboxes for sub unit 1 and sub unit 2 are also displayed. The minimum detectable object size for each unit which is determined by the "Number of axes to be ignored" is automatically displayed.

! Point

- If the unit to which the reduced resolution function is set contains different types of minimum detectable objects, the number of axes to be ignored is adjusted to the GL-R with the smallest type of minimum detectable object. The number of axes to be ignored cannot be set for each unit.
- If the reduced resolution is set with the configuration software, set the setting switch to "Disable". If the configurations for the setting switch and safety device setting software are duplicated, an error will occur.  
📖 "Setting switch" (page 1-11)



■ Interlock

📖 "Interlock Function" (page 2-7)

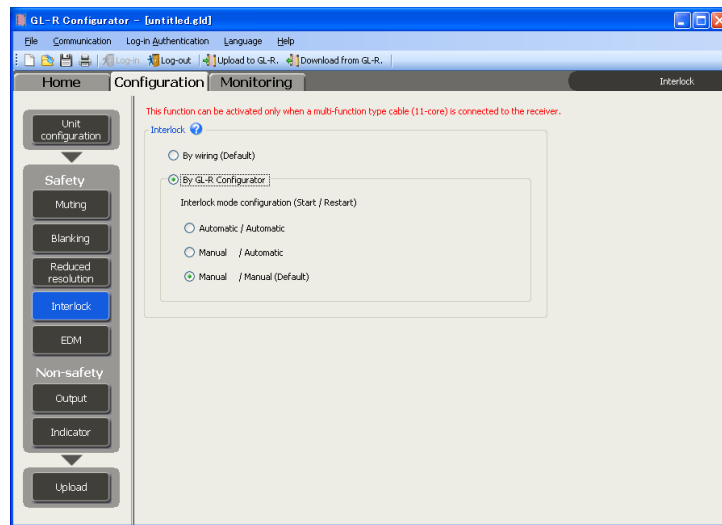

Item	Description
By wiring (Default)	Select to use the interlock function via wiring connections.
By GL-R Configurator	Select to use the interlock function via GL-R Configurator. Any of the following three interlock functions can be selected.
Automatic/Automatic	📖 "2-4 Interlock Function" (page 2-7)
Manual/Automatic	
Manual/Manual (Default)	

📖 "Availability of functions which can be configured by the configuration software" (page 2-5)

■ EDM

📖 "External Device Monitoring (EDM Function)" (page 2-12)

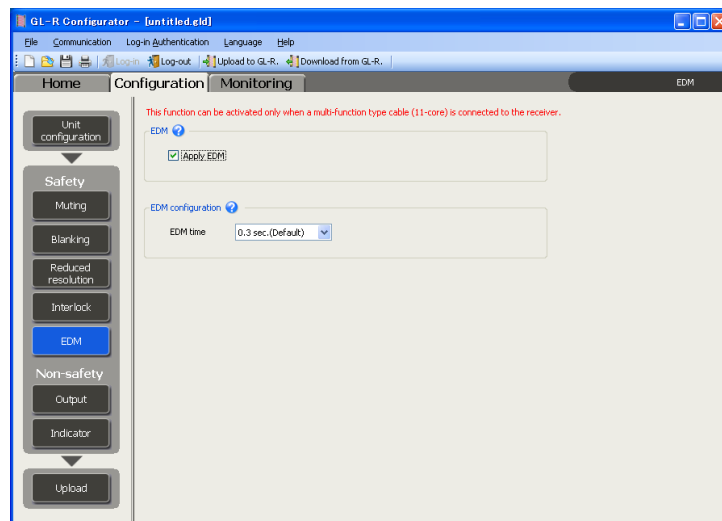

Item	Description
Apply EDM	When the checkbox is ON <input checked="" type="checkbox"/> , the EDM function can be used. The default value is ON.
EDM time	Select the allowable time delay before the EDM fault alert is activated. Setting range: 0.15 sec./0.3 sec. (Default)/0.6 sec./3 sec.

📖 "Availability of functions which can be configured by the configuration software" (page 2-5)

## Non-safety function

### Output

☞ "Non Safety-Related Outputs" (page 2-36)

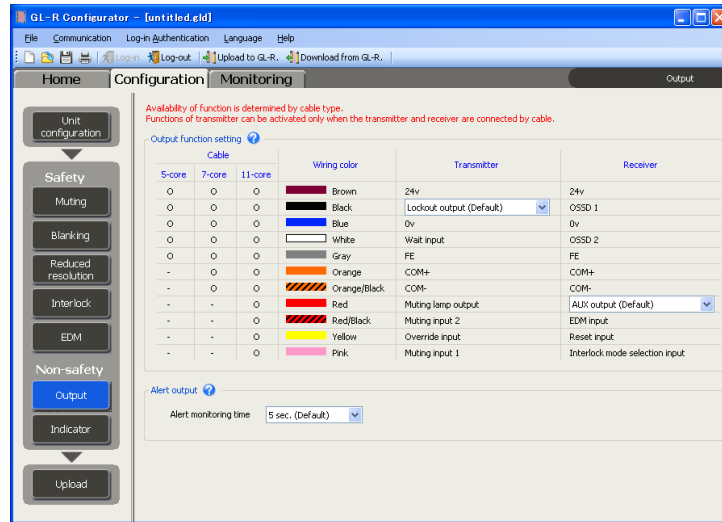

Item	Setting range
Output function setting	AUX (Receiver, Default = red wire), Error output (Transmitter, Default = black wire), Muted condition output, Alert output/Clear•Blocked output, Interlock-reset-ready output
Alert monitoring time	1 sec./5 sec. (Default)/10 sec. ☞ "Alert output" (page 2-39)

☞ "Availability of functions which can be configured by the configuration software" (page 2-5)

### Display setting (Center indicator)

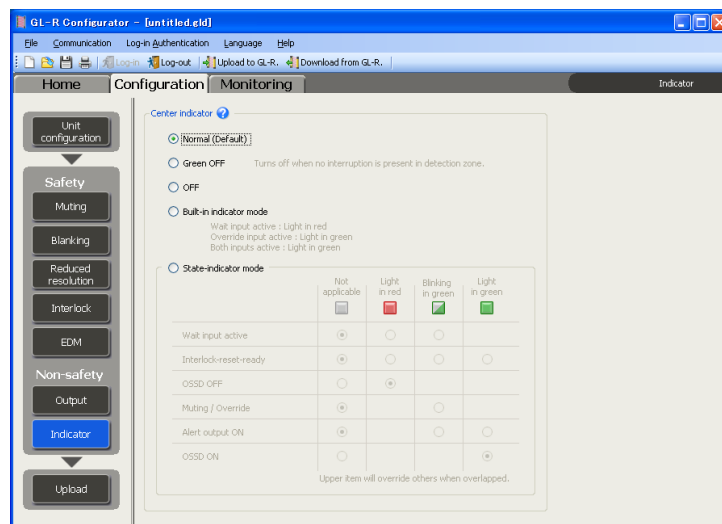

Item	Description
Normal (Default)	-
Green OFF	When all beam axes are receiving light, the center indicators turn off.
OFF	The center indicators are always OFF.
Built-in indicator mode	This controls the center indicator ON/OFF state with an external output.
State-indicator mode	Lighting/Blinking conditions can be set according to the GL-R status.

☞ "Availability of functions which can be configured by the configuration software" (page 2-5)

# 6-10 Monitor Tab

Allows the GL-R status to be monitored. Also, the non-safety outputs can be forcibly turned ON/OFF to confirm operation.

📖 "Non Safety-Related Outputs" (page 2-36)

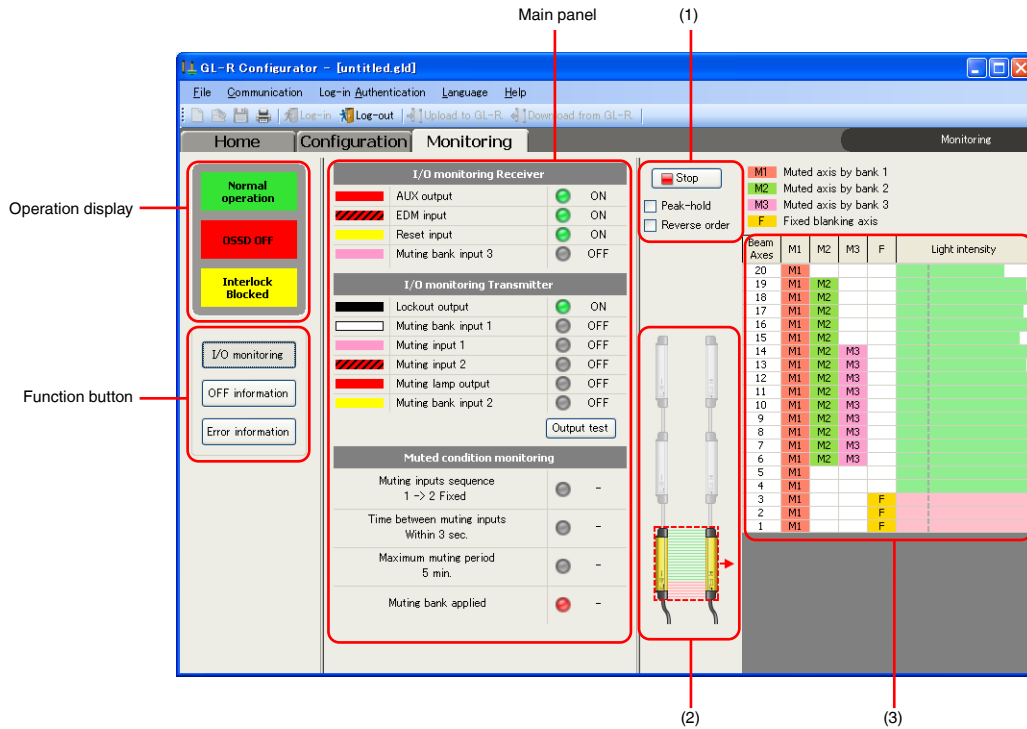

Item	Description
Operation display	This displays the operation status of the GL-R main unit. <ul style="list-style-type: none"> <li>Operation status: Normal operation (Green)/Error (Red)/Wait input (white)/Muting (orange)/Muting (No Bank) (orange)/Override (orange)</li> <li>OSSD status: OSSD ON (Green)/OSSD OFF (Red)</li> <li>Interlock status: Interlock Blocked (Yellow)/Interlock-reset-ready (Yellow)</li> </ul> *When OSSD is ON, the display is grayed out.
Function button/Main panel	Contents displayed on the main panel change depending on which function buttons are selected.
(1) Stop/Start	This starts or stops monitoring the amount of received light that the GL-R main unit connected to the PC receives.
(1) Peak-hold	When the checkbox is ON <input checked="" type="checkbox"/> , the line indicating the peak value for the amount of received light is displayed in the [Amount of received light monitoring area].
(1) Reverse order	When the checkbox is ON <input checked="" type="checkbox"/> , the main unit is displayed as the top unit in the image.
(2) Unit display	When serial connection is made, this shows which unit is set.
(3) Amount of received light monitoring area	Displays the amount of received light on the bar graph. As the bar extends to the right, the amount of received light increases. The color of the bar is green for light received and pink for light blocked. (When the fixed blanking function is applied, the colors for the beam axes are reversed.)

## I/O monitoring

### Main panel

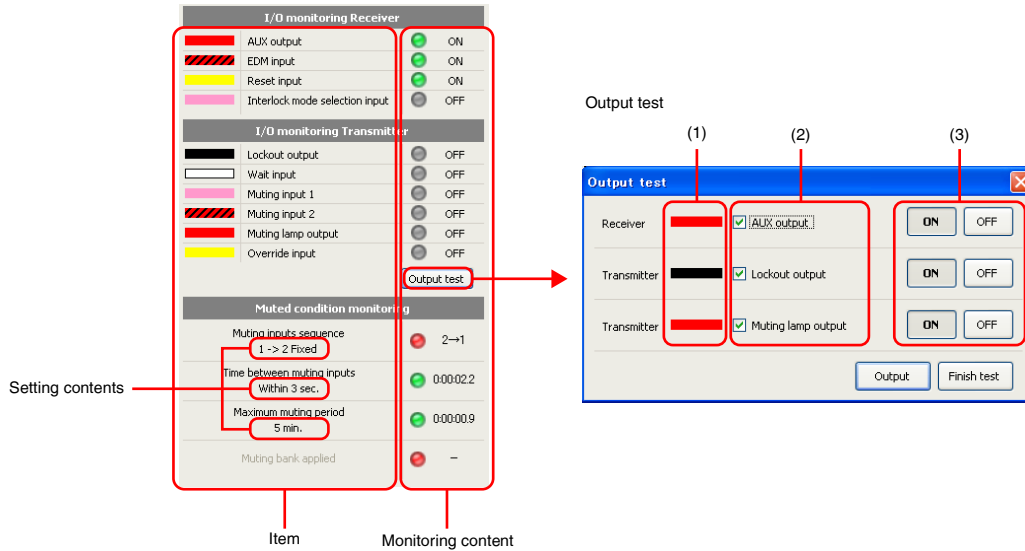

Item	Monitoring content
I/O monitoring Receiver*	This shows the ON/OFF status of each input/output. If the status is ON, the indicator lights in green. If the status is OFF, the indicator turns off.
I/O monitoring Transmitter*	
Muted condition monitoring	This shows whether the muting input and muting time satisfy the set muting conditions. If the conditions are satisfied, the indicator lights in green. If not, the indicator lights in red.
Muting inputs sequence	This shows the sequence when the Muting input 1 and 2 were input last time.
Time between muting inputs	This shows the time difference when the Muting input 1 and 2 were input last time.
Maximum muting period	This shows the muting period when the muting status was established last time.
Muting bank applied	This shows which bank is selected when the muting bank function is used. If the muting bank is not correctly selected (The combination of muting bank input 1 to 3 is not correct.), "-" is displayed.

\* Displayed items will differ depending on the GL-R configuration status.

### Output test

When the output test button is clicked, the [Output test] dialog box appears. The displayed output function varies depending on the GL-R configuration.

Item	Description
(1)	This displays the line color.
(2)	When the checkbox is ON <input checked="" type="checkbox"/> and the [Output] button is clicked, the output test is performed.
(3)	Select whether to forcibly turn the output ON or OFF when the output test is performed.
Output/Finish test	Each time the [Output] button is clicked, the output status is updated according to the configuration status. When the [Finish test] button is clicked, the [Output test] dialog box is closed.

## OFF information

**Point**

If the power supplied to the GL-R main unit is turned off, the OFF information is erased.

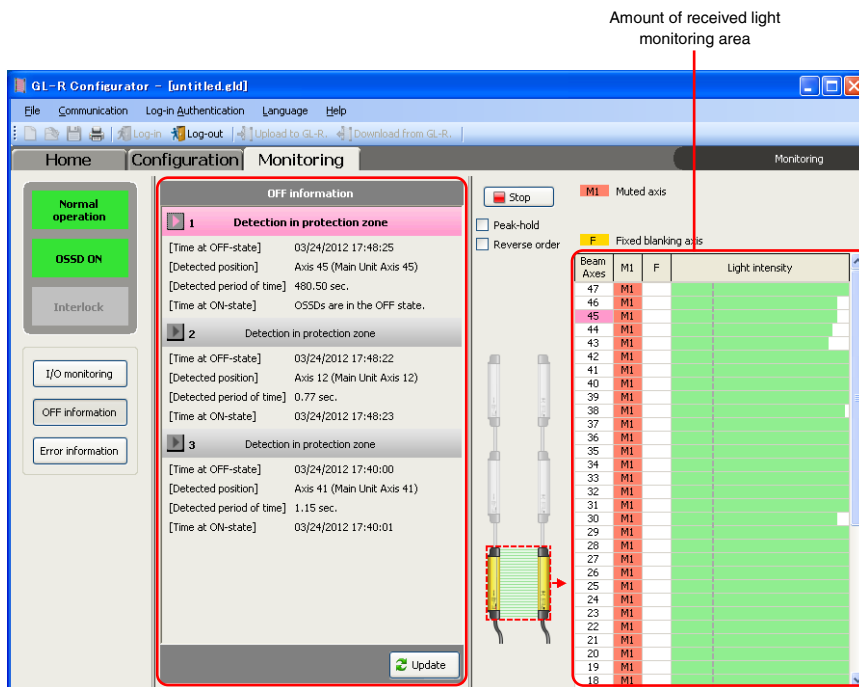

6  
Setting Method Using the Configuration Software

Item	Description
(Detected position selection button)	The beam axis No. which causes the OSSD OFF state is displayed with emphasis in the "Amount of received light monitoring area".
(Number)	OSSD OFF occurrences are displayed. The history of the most recent OSSD OFF state is numbered "1" and the oldest occurrence is numbered "20". Up to 20 OSSD OFF occurrences are displayed.
(History details)	This displays factors that caused the OSSD OFF state. (Detection in protection zone, Error occurred, etc.)
Time at OSSD OFF	This displays the date and time (time of occurrence) when OSSD OFF state occurred.
Detected position	This displays the detected beam axis number.
Detected period of time	This displays the duration of the detection.
Time at OSSD ON	This displays the date and time (for recovery) when the OSSD is switched from the OFF to ON state. When the OSSD state remains off, "OSSDs are in the OFF state." is displayed.
[Update] button	This refreshes to the latest OSSD OFF information.

## Error information

**!** Point

If the power supplied to the GL-R main unit is turned off, the Error information is erased. "Error history" is not erased. "Error history" (page 6-28)

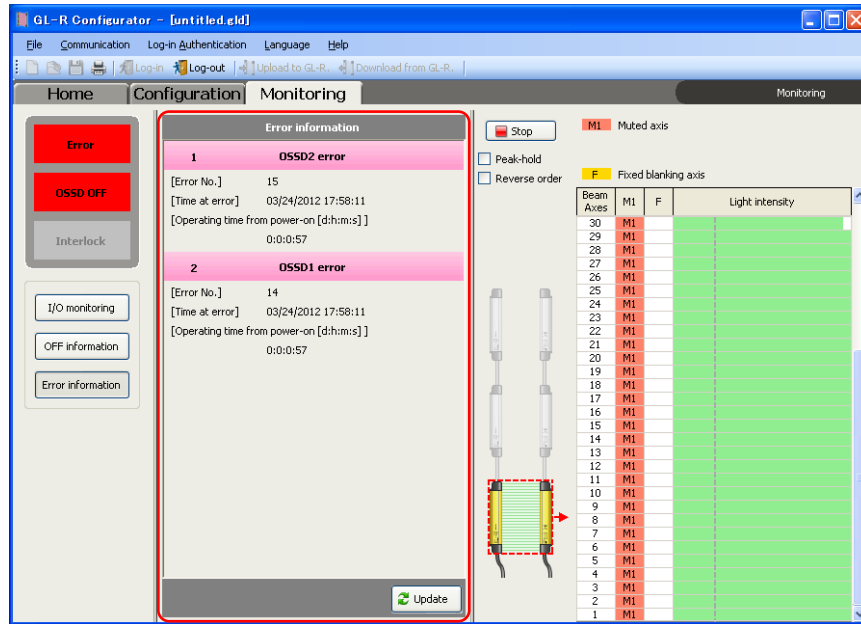

Item	Description
(Number)	If multiple errors occur, numbers are assigned in the order of error occurrence. Up to 128 errors are displayed. (The 129th error and subsequent errors are not displayed.)
(Error details)	This displays the error details. For details of types of error displayed, see  "If the device is in the error condition" (page A-4).
Error No.	This displays the error number.
Time at error	This displays the date and time (time of occurrence) when the error occurred.
Operating time from power-on	This displays the elapsed time from when the power was turned on until the error occurrence.
[Update] button	This refreshes to the latest error history information.

# 6-11 Other Functions

This section explains functions that can only be performed from the menu bar.



Point

When monitoring the GL-R status ("Monitoring tab" is open.), selectable items are limited.

## File (F)

### ■ Locking the configuration file

If the configuration file "xxx.gld" is locked, each configuration for the file cannot be changed. The locked configuration file can only be uploaded to and downloaded from GL-R.

From the menu, select [File(F)] → [Lock File].

When the [Lock file] dialog box appears, enter the unlock password and click [Register].

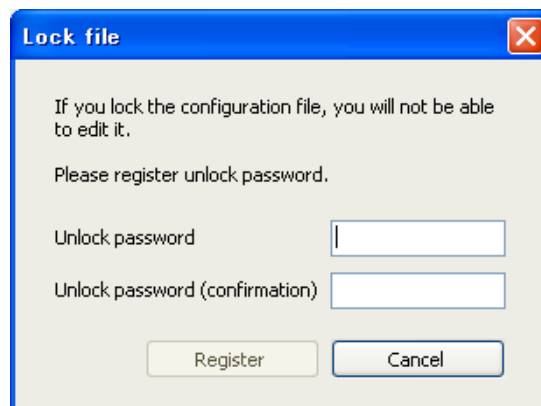

### ■ Unlocking the configuration file

From the menu, select [File (F)]→[Unlock File].

When the [Unlock file] dialog box appears, enter the unlock password and click [OK].

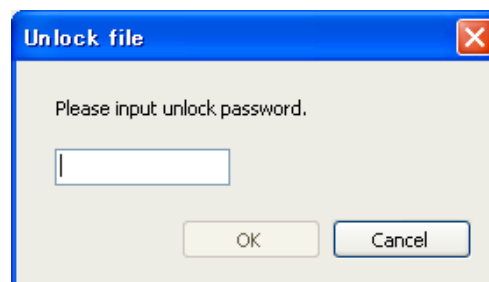

### ■ CSV export

Each configuration can be exported as a CSV file. (OFF history and error history cannot be exported.)

From the menu, select [File (F)] → [Export CSV File].

When the [Save as] dialog box appears, enter the file name and save.

### ■ Importing the SL-V configuration file

From the menu, select [File(F)] → [Import SL-V File].

When the [File open] dialog box appears, select the SL-V configuration file to import, and open.

The SL-V configurations can be transferred over to the GL-R.

## Communication (C)

### Verifying the configuration

From the menu, select [Communication (C)] → [Verification (V)].

Verify the configuration data currently being edited and the configuration data in the GL-R Series main unit. When the verification is complete, the results are displayed on the [Verification results] window.

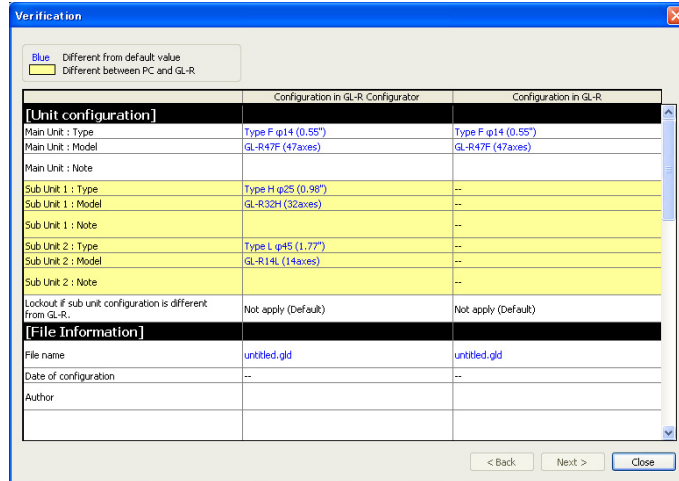

### Error history

From the menu, select [Communication (C)] → [Error History (E)].

The [Error history] dialog box appears. Up to 128 error history occurrences saved. The 129th and subsequent error history occurrences are not saved. The error history can be saved into the GL-R main unit even if the GL-R is turned off.

To generate a new error history report, click [Clear history].

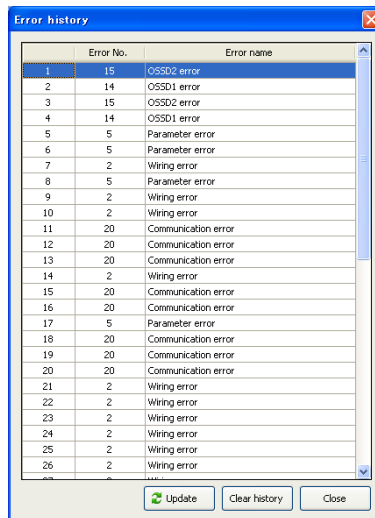

### Initializing the GL-R

From the menu, select [Communication (C)] → [Initialization (I)].

Initialize the GL-R main unit.



**Login is required for initialization.** "Login" (page 6-12)  
 Initializing the unit will return each configuration to the factory default state. (Error history will be erased.)



## Log-in authentication (A)

### ■ Changing the password

From the menu, select [Log-in Authentication (A)] → [Password Change (C)].

When the [Password change] dialog box appears, enter a new password of 4 numeric characters and click [OK].

 Password default: "0000"

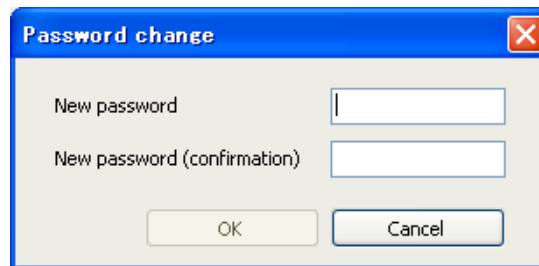

### ■ If you forget the password

From the menu, select [Log-in Authentication (A)] → [Forgot password (F)].

[Reference code] will be displayed in the [Forgot password] dialog box.

Inform this code to the nearest KEYENCE office to obtain the "Password for initialization".

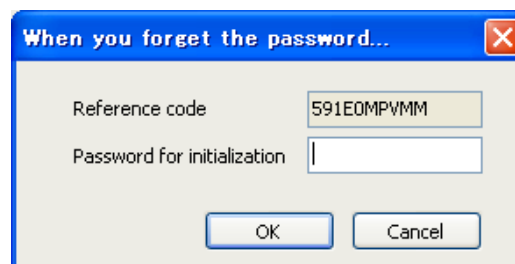

## Language (L)

The display language for the GL-R Configurator can be switched.

### ■ Japanese

From the menu, select [Language (L)] → [Japanese (J)].

The display language for the GL-R Configurator is set to Japanese.

 Point

For Windows without Japanese fonts installed, this item cannot be selected.

### ■ English

From the menu, select [Language (L)] → [English (E)].

The display language for the GL-R Configurator is set to English.

### ■ German

From the menu, select [Language (L)] → [German (G)].

The display language for the GL-R Configurator is set to German.

### ■ Chinese

From the menu, select [Language (L)] → [Chinese (C)].

The display language for the GL-R Configurator is set to Chinese.

## Help (H)

### ■ GL-R User's Manual

From the menu, select [Help (H)] → [GL-R User's Manual (M)].

Using the PDF Reader installed onto the PC, display the PDF data of the GL-R User's manual.



If the PDF Reader has not been installed, install Adobe Systems' Adobe Reader to view this manual. You can download the Adobe Reader for free from the Adobe Systems Incorporated web site: (<http://www.adobe.com>).

### ■ Version information

From the menu, select [Help (H)] → [About GL-R Configurator (A)].

The version information of the GL-R Configurator is displayed.

## **Specifications and Dimensions**

---

---

7-1	Nomenclature of Model Name .....	7-2
7-2	Specifications .....	7-3
7-3	Dimensions .....	7-12

## Transmitter and receiver unit

GL - R 1 2 H - T

The number of beam axe

Example: "08" means 8 axes, "127" means 127 axes

F : Minimum detectable object is  $\phi 14$  mm, Finger protection type

H : Minimum detectable object is  $\phi 25$  mm, Hand protection type

L : Minimum detectable object is  $\phi 45$  mm, Body protection type

T : Transmitter

R : Receiver

## Cable

GL - R P C 5 P M

P : Unit connection cable

PC : Unit connection cable (for extension use)

C : Extension cable

S : Series connection cable

Cable length Example: "008" means 0.08 m

P : PNP type cable

N : NPN type cable

Blank : 5-core cable

S : 7-core cable

M : 11-core cable

## Specifications

Model		GL-RQF	GL-RQH	GL-RQL
Beam axis spacing/Lens diameter		10 mm/φ4	20 mm/φ5	40 mm/φ5
Detection capability		φ14 mm	φ25 mm	φ45 mm
Operating distance		0.2 to 10 m <sup>*1</sup>	0.2 to 15 m <sup>*1</sup>	
Effective aperture angle		Max. ±2.5° (When operating distance is 3 m (9.84 ft.) or more)		
Light source		Infrared LED (870 nm)		
Response time		Optical synchronization (Channel 0) or Wire synchronization: 6.6 to 18.1 ms Optical synchronization (Channel A or B): 6.9 to 27.4 ms ☐ "Response time (OSSD)" (page 7-5)		
OSSD operation		Turns on when no interruptions are present in the detection zone		
Synchronization between the transmitter and receiver		Optical synchronization or Wire synchronization (Determined by wiring)		
Light interference prevention function		Prevents mutual interference in up to two GL-R systems. Optical synchronization: prevented by Channel A and B with setting switch Wire synchronization: prevented automatically		
Control output (OSSD)	Output	2 transistor outputs. (PNP or NPN is determined by the cable type)		
	Max. load current	500 mA <sup>*2</sup>		
	Residual voltage (during ON)	Max. 2.5 V (with a cable length of 5 m (16.4 ft.))		
	OFF state voltage	Max. 2.0 V (with a cable length of 5 m (16.4 ft.))		
	Leakage current	Max. 200 μA		
	Max. capacitive load	2.2 μF		
	Load wiring resistance	Max. 2.5 Ω		
Supplemental output (Non-safety-related output)	AUX	Transistor outputs. (Compatible with both PNP and NPN) Load current: Max. 50 mA, Residual voltage: Max. 2.5 V (with a cable length of 5 m (16.4 ft.))		
	Error output			
	Muting lamp output	Incandescent lamp (24 VDC, 1 to 5.5 W) or LED lamp (load current :10 to 230 mA) can be connected		
Input	EDM input	< with PNP cable > ON-voltage: 10 to 30 V OFF-voltage: Open or 0 to 3 V Short-circuit current: Approx. 2.5 mA (Approx. 10 mA for EDM)		< with NPN cable > ON-voltage: 0 to 3 V OFF-voltage: Open or 10 V to Power voltage Short-circuit current: Approx. 2.5 mA (Approx. 10 mA for EDM)
	Wait input			
	Reset input			
	Muting input 1, 2			
	Override input			
Power supply	Power voltage	DC24 V ± 20% (Ripple P-P 10% or less, Class2)		
	Current consumption	Transmitter: 37 to 81 mA, Receiver: 66 to 91 mA ☐ "Current consumption" (page 7-7)		
Protection circuit		Reverse current protection, short-circuit protection for each output, surge protection for each output		
Environmental resistance	Enclosure rating	IP65 / IP67 (IEC60529)		
	Overtoltage category	II		
	Ambient temperature	-10 to +55°C (No freezing)		
	Storage ambient temperature	-25 to +60°C (No freezing)		
	Relative humidity	15% to 85%RH (No condensation)		
	Storage relative humidity	15% to 95%RH		
	Ambient light	White incandescent lamp: 3,000 lx or less, Sunlight: 20,000 lx or less		
	Vibration	10 to 55 Hz, 0.7 mm compound amplitude, 20 sweeps each in X, Y and Z directions		
	Shock	100 m/s <sup>2</sup> (Approx. 10 G) 16 ms pulse in X, Y and Z directions 1,000 times each axis		
Material	Main unit case	Aluminum		
	Upper case/Lower case	Nylon (GF30 %)		
	Front cover	Polycarbonate, SUS304		
Weight		☐ See "Weight" (page 7-7)		

Model			GL-R0F	GL-R0H	GL-R0L
Approved standard	EMC	EMS	IEC61496-1, EN61496-1, UL61496-1		
		EMI	EN55011 ClassA, FCC Part15B ClassA, ICES-003 ClassA		
	Safety		IEC61496-1, EN61496-1, UL61496-1 (Type 4 ESPE)		
			IEC61496-2, EN61496-2, UL61496-2 (Type 4 AOPD)		
			IEC61508, EN61508 (SIL3), IEC62061, EN62061 (SIL CL3)		
			EN ISO13849-1:2015 (Category 4, PL e)		
			UL508		
			UL1998		

\*1 When the option front protection cover is installed on the one of transmitter or receiver, the Operating distance is shorten by 0.5 m. When the front covers are installed on both of the transmitter and receiver, the Operating distance is shorten by 1.0 m.

\*2 When the GL-R is used under surrounding air temperatures between 50 to 55°C, the Maximum load current should not exceed 350 mA.

■ Parameter for IEC61508

T1 (Proof test interval)	20 years
Hardware fault tolerance	1
Type of element	Type B
Failure response time	Within a response time
Safe state	OSSDs are in OFF-state

● PFHd (average frequency of a dangerous failure per hour)

Model	PFHd
GL-R23F	2.20×10 <sup>-9</sup>
GL-R31F	2.43×10 <sup>-9</sup>
GL-R39F	2.65×10 <sup>-9</sup>
GL-R47F	2.88×10 <sup>-9</sup>
GL-R55F	3.11×10 <sup>-9</sup>
GL-R63F	3.33×10 <sup>-9</sup>
GL-R71F	3.56×10 <sup>-9</sup>
GL-R79F	3.78×10 <sup>-9</sup>
GL-R87F	4.01×10 <sup>-9</sup>
GL-R95F	4.24×10 <sup>-9</sup>
GL-R103F	4.47×10 <sup>-9</sup> *1
GL-R111F	4.69×10 <sup>-9</sup>
GL-R119F	4.92×10 <sup>-9</sup>
GL-R127F	5.14×10 <sup>-9</sup>

Model	PFHd
GL-R08H	1.86×10 <sup>-9</sup>
GL-R12H	2.01×10 <sup>-9</sup>
GL-R16H	2.10×10 <sup>-9</sup>
GL-R20H	2.25×10 <sup>-9</sup>
GL-R24H	2.34×10 <sup>-9</sup>
GL-R28H	2.48×10 <sup>-9</sup>
GL-R32H	2.58×10 <sup>-9</sup>
GL-R36H	2.72×10 <sup>-9</sup>
GL-R40H	2.81×10 <sup>-9</sup>
GL-R44H	2.96×10 <sup>-9</sup>
GL-R48H	3.05×10 <sup>-9</sup>
GL-R52H	3.20×10 <sup>-9</sup>
GL-R56H	3.29×10 <sup>-9</sup>
GL-R60H	3.43×10 <sup>-9</sup>
GL-R64H	3.53×10 <sup>-9</sup>
GL-R72H	3.76×10 <sup>-9</sup>
GL-R80H	4.00×10 <sup>-9</sup>
GL-R88H	4.24×10 <sup>-9</sup>
GL-R96H	4.48×10 <sup>-9</sup>

Model	PFHd
GL-R04L	1.79×10 <sup>-9</sup> *2
GL-R06L	1.90×10 <sup>-9</sup>
GL-R08L	1.94×10 <sup>-9</sup>
GL-R10L	2.06×10 <sup>-9</sup>
GL-R12L	2.10×10 <sup>-9</sup>
GL-R14L	2.22×10 <sup>-9</sup>
GL-R16L	2.26×10 <sup>-9</sup>
GL-R18L	2.38×10 <sup>-9</sup>
GL-R20L	2.42×10 <sup>-9</sup>
GL-R22L	2.54×10 <sup>-9</sup>
GL-R24L	2.58×10 <sup>-9</sup>
GL-R26L	2.70×10 <sup>-9</sup>
GL-R28L	2.74×10 <sup>-9</sup>
GL-R30L	2.85×10 <sup>-9</sup>
GL-R32L	2.90×10 <sup>-9</sup>

\*1 This shows when PNP output cable is used. When NPN output cable is used, the figure is 4.46×10<sup>-9</sup>.

\*2 This shows when PNP output cable is used. When NPN output cable is used, the figure is 1.78×10<sup>-9</sup>.

\*3 For PFHd of GL-R in serial connection, contact your nearest KEYENCE office.

## Response time (OSSD)

### ■ GL-RF

Units: ms

Model	Response time (OSSD)					
	Wire synchronization, One-line or Optical synchronization system (Channel 0)			Optical synchronization system (Channel A or B)		
	ON→OFF	OFF→ON *1	All blocked→ON *2	ON→OFF	OFF→ON *1	All blocked→ON *2
GL-R23F	6.9	49.2	64.4	9.3	52.7	74.0
GL-R31F	7.8	50.5	67.9	10.7	54.8	79.5
GL-R39F	8.6	51.8	71.3	12.1	56.9	85.1
GL-R47F	9.5	53.1	74.8	13.5	59.0	90.7
GL-R55F	10.4	54.3	78.3	14.9	61.1	96.3
GL-R63F	11.2	55.6	81.7	16.3	63.2	101.8
GL-R71F	12.1	56.9	85.2	17.6	65.3	107.4
GL-R79F	13.0	58.2	88.6	19.0	67.4	113.0
GL-R87F	13.8	59.5	92.1	20.4	69.4	118.5
GL-R95F	14.7	60.8	95.5	21.8	71.5	124.1
GL-R103F	15.5	62.1	99.0	23.2	73.6	129.7
GL-R111F	16.4	63.4	102.4	24.6	75.7	135.2
GL-R119F	17.3	64.7	105.9	26.0	77.8	140.8
GL-R127F	18.1	66.0	109.4	27.4	79.9	146.4

### ■ GL-RH

Units: ms

Model	Response time (OSSD)					
	Wire synchronization, One-line or Optical synchronization system (Channel 0)			Optical synchronization system (Channel A or B)		
	ON→OFF	OFF→ON *1	All blocked→ON *2	ON→OFF	OFF→ON *1	All blocked→ON *2
GL-R08H	6.6	48.7	63.1	6.9	49.1	64.2
GL-R12H	6.6	48.7	63.1	7.4	49.9	66.3
GL-R16H	6.6	48.7	63.1	8.1	50.9	69.1
GL-R20H	6.6	48.7	63.1	8.8	52.0	71.9
GL-R24H	7.0	49.3	64.9	9.5	53.0	74.7
GL-R28H	7.4	50.0	66.6	10.2	54.0	77.5
GL-R32H	7.9	50.6	68.3	10.9	55.1	80.2
GL-R36H	8.3	51.3	70.0	11.6	56.1	83.0
GL-R40H	8.7	51.9	71.8	12.3	57.2	85.8
GL-R44H	9.2	52.6	73.5	12.9	58.2	88.6
GL-R48H	9.6	53.2	75.2	13.6	59.3	91.4
GL-R52H	10.0	53.9	77.0	14.3	60.3	94.2
GL-R56H	10.5	54.5	78.7	15.0	61.4	96.9
GL-R60H	10.9	55.2	80.4	15.7	62.4	99.7
GL-R64H	11.3	55.8	82.1	16.4	63.4	102.5
GL-R72H	12.2	57.1	85.6	17.8	65.5	108.1
GL-R80H	13.1	58.4	89.1	19.2	67.6	113.7
GL-R88H	13.9	59.7	92.5	20.6	69.7	119.2
GL-R96H	14.8	61.0	96.0	22.0	71.8	124.8

■ GL-RL

Units: ms

Model	Response time (OSSD)					
	Wire synchronization, One-line or Optical synchronization system (Channel 0)			Optical synchronization system (Channel A or B)		
	ON→OFF	OFF→ON *1	All blocked→ON *2	ON→OFF	OFF→ON *1	All blocked→ON *2
GL-R04L	6.6	48.7	63.1	6.9	49.1	64.2
GL-R06L	6.6	48.7	63.1	6.9	49.1	64.2
GL-R08L	6.6	48.7	63.1	6.9	49.1	64.2
GL-R10L	6.6	48.7	63.1	7.0	49.3	64.9
GL-R12L	6.6	48.7	63.1	7.4	49.9	66.3
GL-R14L	6.6	48.7	63.1	7.7	50.4	67.7
GL-R16L	6.6	48.7	63.1	8.1	50.9	69.1
GL-R18L	6.6	48.7	63.1	8.4	51.4	70.5
GL-R20L	6.6	48.7	63.1	8.8	52.0	71.9
GL-R22L	6.8	49.0	64.0	9.1	52.5	73.3
GL-R24L	7.0	49.3	64.9	9.5	53.0	74.7
GL-R26L	7.2	49.6	65.7	9.8	53.5	76.1
GL-R28L	7.4	50.0	66.6	10.2	54.0	77.5
GL-R30L	7.7	50.3	67.5	10.5	54.6	78.9
GL-R32L	7.9	50.6	68.3	10.9	55.1	80.2

\*1 If the interruption is present in the detection zone for less than 80 ms, the response time (OFF to ON) will be 80 ms or more to ensure that the OSSD maintains the OFF state for more than 80 ms.

\*2 "All blocked" means the situation where the GL-R operates in optical synchronization system and the transmitter and receiver is not synchronized (top and bottom beam axes are both blocked). In this situation, the response time is longer because the GL-R synchronizes the transmitter and receiver first and then determines the clear or blocked.

! Point

- When the GL-R units are connected in series, the response time is calculated according to the following steps;
  1. Sum up the response time of all unit.
  2. Subtract the following time from the result of previous step.
    - ON to OFF
      - One sub unit : 2 ms
      - Two sub unit : 4.2 ms
    - (When Optical synchronization system and Channel A or B)
      - One sub unit : 2.7 ms
      - Two sub unit : 5.7 ms
    - OFF to ON
      - One sub unit : 42 ms
      - Two sub unit : 84 ms

When connecting the GL-R32H (32 beam axes), GL-R24H (24 beam axes), and GL-R12L (12 beam axes) in series for one-line system, the response time of each unit is 7.9 ms, 7.0 ms, and 6.6 ms respectively, and the response time (ON to OFF) is 7.9 ms + 7.0 ms + 6.6 ms - 4.2 ms = 17.3 ms.  
 the response time (OFF to ON) is 50.6 ms + 49.3 ms + 48.7 ms - 84 ms = 64.6 ms.

☐ "Series connection" (page 2-3)
- 2.0 m/s is the maximum object detection speed of the GL-R series.



## Current consumption

Units: mA

Model	Current consumption (Max.)	
	Transmitter	Receiver
GL-R23F	50	70
GL-R31F	54	71
GL-R39F	57	72
GL-R47F	60	74
GL-R55F	62	75
GL-R63F	64	77
GL-R71F	66	78
GL-R79F	67	80
GL-R87F	69	81
GL-R95F	71	83
GL-R103F	72	84
GL-R111F	74	85
GL-R119F	76	87
GL-R127F	78	89

Units: mA

Model	Current consumption (Max.)	
	Transmitter	Receiver
GL-R08H	43	66
GL-R12H	46	68
GL-R16H	50	69
GL-R20H	53	71
GL-R24H	57	72
GL-R28H	59	73
GL-R32H	61	74
GL-R36H	63	75
GL-R40H	65	76
GL-R44H	66	77
GL-R48H	68	79
GL-R52H	69	80
GL-R56H	71	81
GL-R60H	72	82
GL-R64H	73	83
GL-R72H	75	85
GL-R80H	77	87
GL-R88H	79	89
GL-R96H	81	91

Units: mA

Model	Current consumption (Max.)	
	Transmitter	Receiver
GL-R04L	37	66
GL-R06L	39	67
GL-R08L	41	68
GL-R10L	43	69
GL-R12L	46	70
GL-R14L	48	71
GL-R16L	50	72
GL-R18L	52	73
GL-R20L	54	75
GL-R22L	56	75
GL-R24L	57	76
GL-R26L	59	77
GL-R28L	60	78
GL-R30L	61	79
GL-R32L	62	80

\*1 The above current consumption does not include the current consumed via OSSD output.

\*2 If inputs other than EDM input turn on, consumption current per input increases by 2.5 mA.

## Weight

### ■ Transmitter and receiver unit

Units: g

Model	Weight	
	Transmitter	Receiver
GL-R23F	320	330
GL-R31F	430	440
GL-R39F	550	550
GL-R47F	660	670
GL-R55F	780	780
GL-R63F	890	900
GL-R71F	1000	1010
GL-R79F	1200	1200
GL-R87F	1300	1300
GL-R95F	1400	1400
GL-R103F	1500	1500
GL-R111F	1600	1600
GL-R119F	1700	1700
GL-R127F	1800	1900

Units: g

Model	Weight	
	Transmitter	Receiver
GL-R08H	210	210
GL-R12H	320	330
GL-R16H	430	440
GL-R20H	550	550
GL-R24H	660	660
GL-R28H	770	770
GL-R32H	880	890
GL-R36H	1000	1000
GL-R40H	1110	1110
GL-R44H	1220	1220
GL-R48H	1330	1340
GL-R52H	1440	1450
GL-R56H	1560	1560
GL-R60H	1670	1680
GL-R64H	1780	1790
GL-R72H	2010	2010
GL-R80H	2230	2240
GL-R88H	2450	2460
GL-R96H	2680	2690

Units: g

Model	Weight	
	Transmitter	Receiver
GL-R04L	210	210
GL-R06L	320	330
GL-R08L	430	440
GL-R10L	550	550
GL-R12L	660	660
GL-R14L	770	770
GL-R16L	880	890
GL-R18L	1000	1000
GL-R20L	1110	1110
GL-R22L	1220	1220
GL-R24L	1330	1340
GL-R26L	1440	1450
GL-R28L	1560	1560
GL-R30L	1670	1680
GL-R32L	1780	1790

■ Cable

● Unit connection cable

Units: g

Model	Weight
GL-RP5P	200
GL-RP5PS	215
GL-RP5PM	240
GL-RP10P	400
GL-RP10PS	430
GL-RP10PM	480
GL-RP5N	200
GL-RP5NS	215
GL-RP5NM	240
GL-RP10N	400
GL-RP10NS	430
GL-RP10NM	480

● Unit connection cable (for extension use)

Units: g

Model	Weight
GL-RPC03P	25
GL-RPC03PS	30
GL-RPC03PM	35
GL-RPC03N	25
GL-RPC03NS	30
GL-RPC03NM	35

● Series connection cable

Units: g

Model	Weight
GL-RS008	16
GL-RS015	20
GL-RS05	40
GL-RS1	70
GL-RS3	165
GL-RS5	260
GL-RS10	520

● Extension cable

Units: g

Model	Weight
GL-RC5	205
GL-RC5S	220
GL-RC5M	245
GL-RC10	400
GL-RC10S	430
GL-RC10M	480
GL-RC20	770
GL-RC20S	830
GL-RC20M	910

■ Mounting bracket and antivibration bracket

Units: g

Model	Weight
GL-RB01	260
GL-RB02	290
GL-RB11	150
GL-RB12	160
GL-RB21	470
GL-RB31	50
GL-RB32	270

■ Front protection cover

Units: g

Model	Weight
GL-RA160	15
GL-RA240	23
GL-RA320	30
GL-RA400	38
GL-RA480	45
GL-RA560	53
GL-RA640	60

Units: g

Model	Weight
GL-RA720	68
GL-RA800	75
GL-RA880	83
GL-RA960	90
GL-RA1040	98
GL-RA1120	105
GL-RA1200	113

Units: g

Model	Weight
GL-RA1280	120
GL-RA1440	135
GL-RA1600	150
GL-RA1760	165
GL-RA1920	180

## ■ Corner mirror

Units: kg

Model	Weight*
SL-M12H	1.4
SL-M16H	1.6
SL-M20H	1.8
SL-M24H	2
SL-M28H	2.2
SL-M32H	2.4

\* With mounting brackets

Units: kg

Model	Weight*
SL-M36H	2.6
SL-M40H	2.8
SL-M44H	3
SL-M48H	3.2
SL-M52H	3.7
SL-M56H	3.9

\* With mounting brackets

Units: kg

Model	Weight*
SL-M60H	4.1
SL-M64H	4.3
SL-M80H	5.4
SL-M96H	6.2

\* With mounting brackets

## ■ Laser Alignment Tool

Units: g

Model	Weight
GL-R1LP	260

## ■ Configuration software related items

Units: g

Model	Weight
GL-R1UB	10
OP-51580	70
OP-86941	200

## ■ Dedicated Safety Reley for the GL-R Series

Units: g

Model	Weight
GL-T11R	310

## Packaged items and materials

### ■ Transmitter and receiver

Type	Model	Packaged item	Number of items	Material
Finger protection type	GL-R□F	Transmitter	1	Unit case: Aluminum, Upper/Lower case: Nylon (GF30%), Front cover: Polycarbonate/SUS304
		Receiver	1	
		Test piece (φ14 mm, L 200 mm)	1	ABS
		Instruction manual	1	—
Hand protection type	GL-R□H	Transmitter	1	Unit case: Aluminum, Upper/Lower case: Nylon (GF30%), Front cover: Polycarbonate/SUS304
		Receiver	1	
		Test piece (φ25 mm, L 200 mm)	1	ABS
		Instruction manual	1	—
Body protection type	GL-R□L	Transmitter	1	Unit case: Aluminum, Upper/Lower case: Nylon (GF30%), Front cover: Polycarbonate/SUS304
		Receiver	1	
		Instruction manual	1	—

### ■ Cable

Type	Model	Packaged item	Number of items	Material
Unit connection cable	GL-RP□	Cable	1	Unit connector: PBT, Cable: PVC
Unit connection cable (for extension use)	GL-RPC□	Cable	1	Unit connector: PBT, Extension connector: PVC/Brass Nickel plate, Cable: PVC
Extension cable	GL-RC□	Cable	1	Extension connector: PVC/Brass Nickel plate, Cable: PVC
Series connection cable	GL-RS□	Cable	1	Unit connector: PBT, Cable: PVC

### ■ Mounting bracket and antivibration bracket

Type	Model	Packaged item	Number of items	Material
Adjustable angle mounting bracket	GL-RB01	Assembled bracket	2	Bracket/Nut: SPHC, Hexagon socket bolt: Iron (Trivalent black)
		Instruction manual	1	
Adjustable angle mounting bracket	GL-RB02	Assembled bracket	2	Bracket/Nut: SPHC, Hexagon socket bolt: Iron (Trivalent black)
		Instruction manual	1	
Straight mounting bracket	GL-RB11	Assembled bracket	2	Bracket/Nut: SPHC, Hexagon socket bolt: Iron (Trivalent black)
L-shaped mounting bracket	GL-RB12	Assembled bracket	2	Bracket/Nut: SPHC, Hexagon socket bolt: Iron (Trivalent black)
		Instruction manual	1	
No dead zone mounting bracket	GL-RB21	Assembled bracket	2	Bracket/Nut: SPHC, Hexagon socket bolt: Iron (Trivalent black)
		Instruction manual	1	
Antivibration bracket for the adjustable angle mounting bracket	GL-RB32	Antivibration elastomer	2	EPDM
		Bracket	2	SPHC
		Instruction manual	1	—
Antivibration bracket for the straight mounting bracket	GL-RB31	Antivibration elastomer	2	EPDM
		Hexagon socket bolt	4	Iron (Trivalent black)
		Washer	4	Iron (Trivalent black)
		Spacer	4	SUS303
		Instruction manual	1	—

## ■ Front protection cover

Type	Model	Packaged item	Number of items	Material
Front protection cover	GL-RA□	Front protection cover	1	Frame: ABS, Transparent part: Polycarbonate

## ■ Corner mirror

Type	Model	Packaged item	Number of items	Material
Corner mirror	SL-M12H : SL-M48H	Mirror	1	Mirror: Glass (Back-surface mirror), Case: Aluminum
		Mounting bracket	4	SUS304
		Hexagon socket bolt (M6, width across flat: 5 mm)	12	SUS304
		Nut (M6)	4	SUS304
	SL-M52H : SL-M64H	Mirror	1	Mirror: Back-surface mirror, Case: Aluminum
		Mounting bracket	6	SUS304
		Hexagon socket bolt (M6, width across flat: 5 mm)	18	SUS304
		Nut (M6)	6	SUS304
	SL-M80H SL-M96H	Mirror	1	Mirror: Back-surface mirror, Case: Aluminum
		Mounting bracket	8	SUS304
		Hexagon socket bolt (M6, width across flat: 5 mm)	24	SUS304
		Nut (M6)	8	SUS304

## ■ Laser Alignment Tool

Type	Model	Packaged item	Number of items	Material
Laser Alignment Tool	GL-R1LP	Laser Alignment Tool	1	Case: aluminum
		Laser Warning, Explanation Labels	1	
		Instruction Manual	1	

## ■ Configuration software related items

Type	Model	Packaged item	Number of items	Material
Configuration software	—	—	1	—
Interface unit	GL-R1UB	Interface unit	1	Polycarbonate
USB cable 2 m	OP-51580	USB cable	1	—
USB cable 5 m	OP-86941	USB cable	1	—

## ■ Dedicated Safety Relay for the GL-R Series

Type	Model	Packaged item	Number of items	Material
Dedicated Safety Relay for the GL-R Series	GL-T11R	Relay terminal	1	Main unit case: Polycarbonate
		Instruction Manual	1	

# 7-3 Dimensions

## GL-RF/RH/RL unit

Units: mm

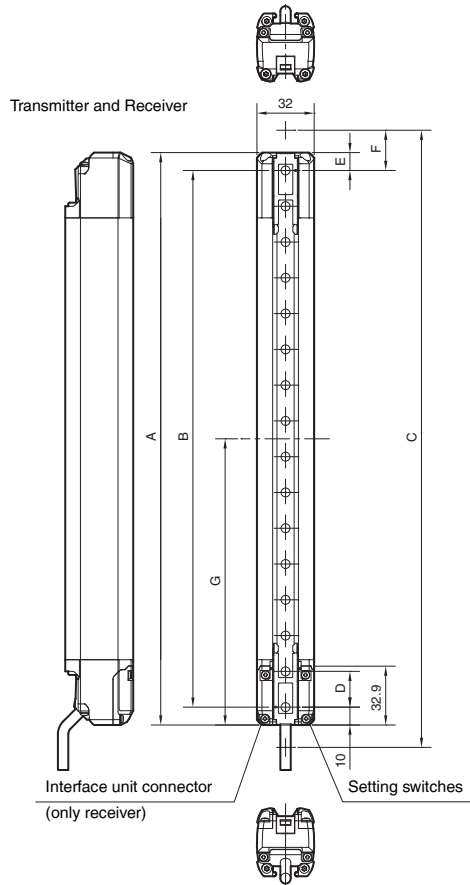

7

Specifications and Dimensions

<b>NOTICE</b>	<p>If the length for a single GL-R unit is 1280 mm or greater, use the following antivibration mounting bracket additionally as an intermediate support bracket. The antivibration mounting bracket must be selected according to the mounting bracket and installed on the center of the GL-R unit indicated as position "G".</p>	
	Mounting bracket	Antivibration bracket
	Adjustable angle mounting bracket	Antivibration bracket for the adjustable mounting bracket
	No dead zone mounting bracket	Antivibration bracket for the straight mounting bracket
	Straight mounting bracket	Antivibration bracket for the L-shaped mounting bracket
L-shaped mounting bracket	L-shaped mounting bracket	

## ■ GL-RF

Units: mm

Model	Beam axes	A: Length	B: Detection height	C: Protection height	D: Beam axis pitch	E	F	G
GL-R23F	23	240	220	244	10	10	12	120
GL-R31F	31	320	300	324				160
GL-R39F	39	400	380	404				200
GL-R47F	47	480	460	484				240
GL-R55F	55	560	540	564				280
GL-R63F	63	640	620	644				320
GL-R71F	71	720	700	724				360
GL-R79F	79	800	780	804				400
GL-R87F	87	880	860	884				440
GL-R95F	95	960	940	964				480
GL-R103F	103	1040	1020	1044				520
GL-R111F	111	1120	1100	1124				560
GL-R119F	119	1200	1180	1204				600
GL-R127F	127	1280	1260	1284				640

## ■ GL-RH

Units: mm

Model	Beam axes	A: Length	B: Detection height	C: Protection height	D: Beam axis pitch	E	F	G
GL-R08H	8	160	140	185	20	10	22.5	80
GL-R12H	12	240	220	265				120
GL-R16H	16	320	300	345				160
GL-R20H	20	400	380	425				200
GL-R24H	24	480	460	505				240
GL-R28H	28	560	540	585				280
GL-R32H	32	640	620	665				320
GL-R36H	36	720	700	745				360
GL-R40H	40	800	780	825				400
GL-R44H	44	880	860	905				440
GL-R48H	48	960	940	985				480
GL-R52H	52	1040	1020	1065				520
GL-R56H	56	1120	1100	1145				560
GL-R60H	60	1200	1180	1225				600
GL-R64H	64	1280	1260	1305				640
GL-R72H	72	1440	1420	1465				720
GL-R80H	80	1600	1580	1625				800
GL-R88H	88	1760	1740	1785				880
GL-R96H	96	1920	1900	1945				960

■ GL-RL

Units: mm

Model	Beam axes	A: Length	B: Detection height	C: Protection height	D: Beam axis pitch	E	F	G
GL-R04L	4	160	120	205	40	30	42.5	80
GL-R06L	6	240	200	285				120
GL-R08L	8	320	280	365				160
GL-R10L	10	400	360	445				200
GL-R12L	12	480	440	525				240
GL-R14L	14	560	520	605				280
GL-R16L	16	640	600	685				320
GL-R18L	18	720	680	765				360
GL-R20L	20	800	760	845				400
GL-R22L	22	880	840	925				440
GL-R24L	24	960	920	1005				480
GL-R26L	26	1040	1000	1085				520
GL-R28L	28	1120	1080	1165				560
GL-R30L	30	1200	1160	1245				600
GL-R32L	32	1280	1240	1325				640

Adjustable angle mounting bracket (Model: GL-RB01)

Units: mm

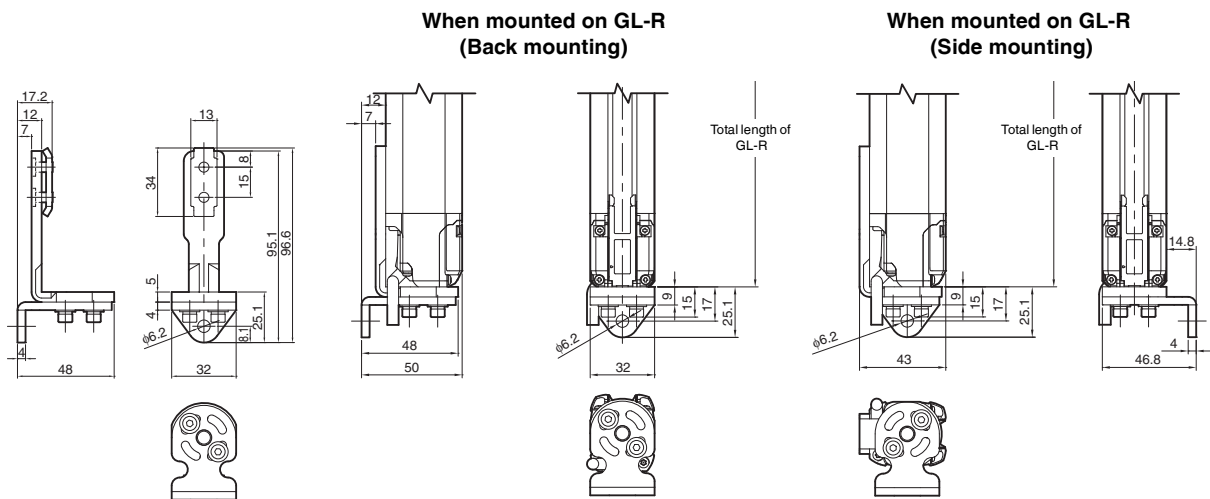

Adjustable angle mounting bracket (Model: GL-RB02)

Units: mm

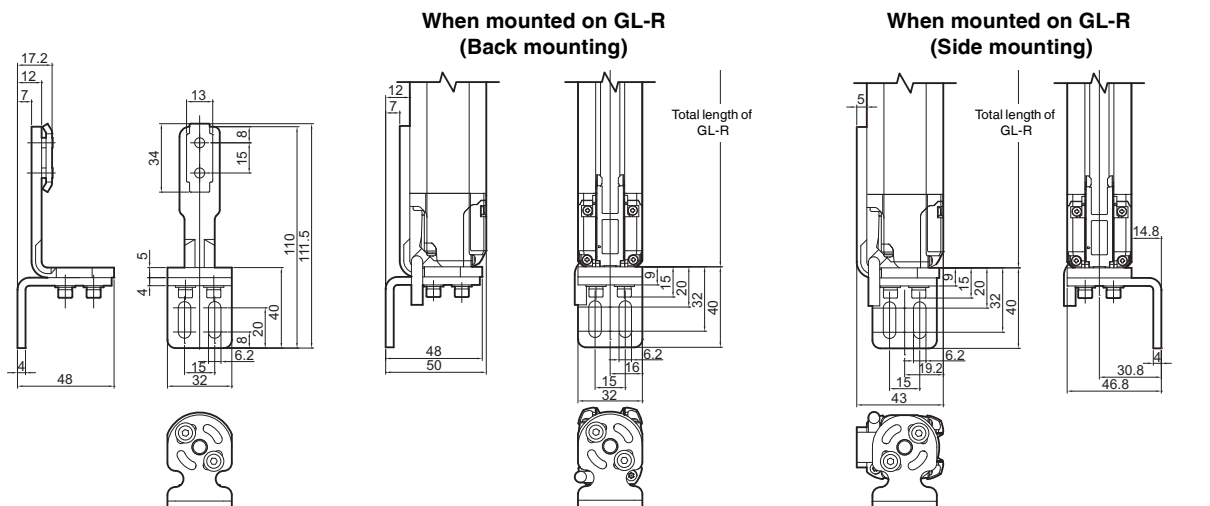









Front protection cover (Model: GL-RA□)

Units: mm

When mounted on GL-R

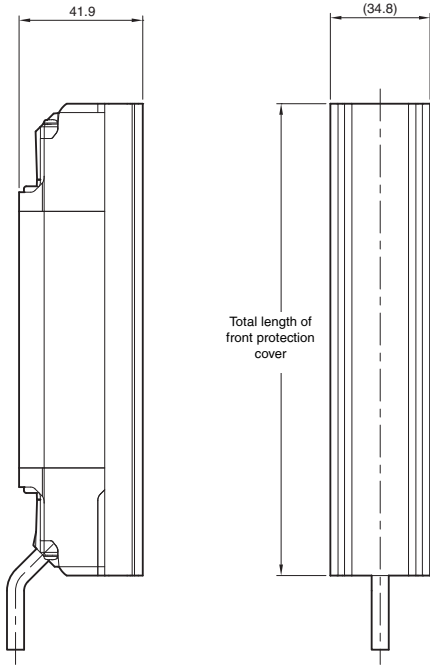

Model	Total length
GL-RA160	160
GL-RA240	240
GL-RA320	320
GL-RA400	400
GL-RA480	480
GL-RA560	560
GL-RA640	640
GL-RA720	720
GL-RA800	800
GL-RA880	880
GL-RA960	960
GL-RA1040	1040
GL-RA1120	1120
GL-RA1200	1200
GL-RA1280	1280
GL-RA1440	1440
GL-RA1600	1600
GL-RA1760	1760
GL-RA1920	1920

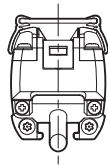

Interface unit (Model: GL-R1UB)

Units: mm

When mounted on GL-R

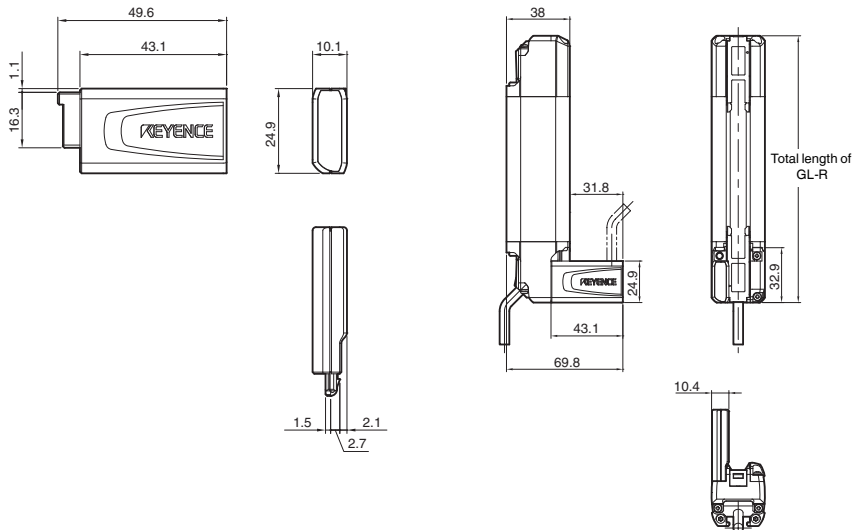

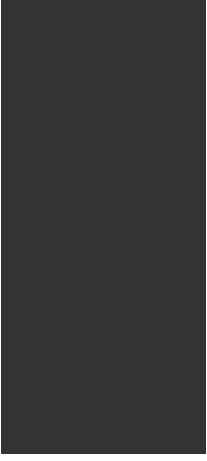

# Appendix

---

---

1	Troubleshooting .....	A-2
2	Checklist .....	A-8

If the GL-R is not functioning normally, check the GL-R indicators first.

The GL-R is in an error condition under the following situations.

- The center indicators blink in red.
- The 7-segment display indicates "E".

If the GL-R does not demonstrate the above situations, the GL-R is not in an error condition.

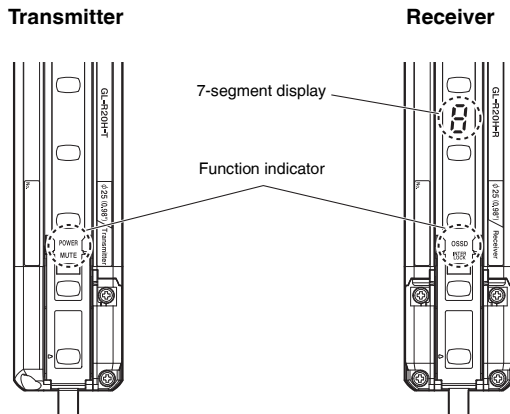

## Error condition

The GL-R performs self-diagnosis for approx. 2 seconds after the power is turned on and checks for errors. Self-diagnosis is also performed periodically during normal operations.

If the self-diagnosis function detects an error, the GL-R goes to an error condition and the OSSD is kept in the OFF state even if no interruption exists in the detection zone. The indicators operate in the following manner during an error condition.

- |                   |  |
|-------------------|--|
| 7-segment display | : Indication corresponding to the cause of the error<br>□ "Troubleshooting" (page A-2)                 |
| Center indicators | : All indicators are blinking in red.<br>□ "Center Indicator" (page 5-4)                               |
| Error output      | : OFF<br>□ "Error output (Default function on the black wire of the transmitter cable)"<br>(page 2-37) |

To release the error condition, first remove the cause of the error, and then either activate the reset input or turn the power off and on again.

## Self-diagnosis description

### ● Transmitter

- Error in the external power supply voltage
- Failure in the internal power supply circuit
- Failure in the light emitting element or light receiving circuit
- CPU overdrive
- Memory error
- Cable open/short-circuit

### ● Receiver

- Error in the external power supply voltage
- Failure in the internal power supply circuit
- Failure in the light receiving element or detection circuit
- CPU overdrive
- Memory error
- Failure in the safety output circuit (OSSD)
- Cable open/short-circuit
- Program monitoring

■ In case where the GL-R goes back to the normal operation with reset operation

● "Automatic start mode"

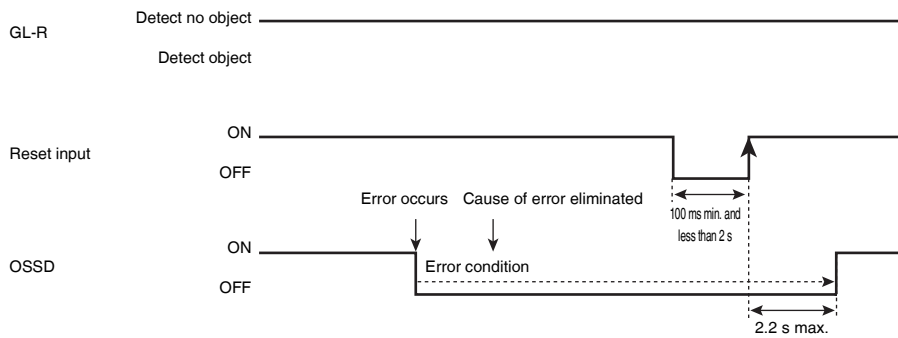

● "Manual start mode"

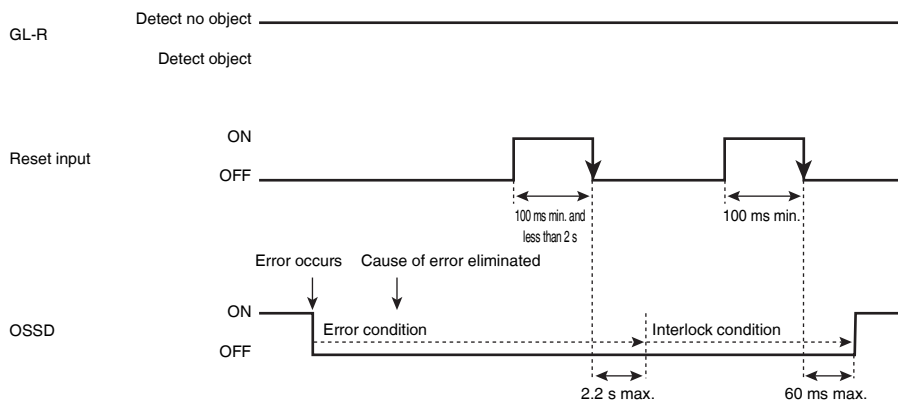

See □ "Wiring" (page 2-9) for the wiring of reset input.

## If the device is in the error condition

Indication	Error name	Cause	Check and corrective action	
E→2	Wiring error	The end cover on the receiver is not connected.	Check that the end cover is installed on the receiver correctly. ☐ "Cable Installation" (page 3-11)	
		The unit connection cable is connected to the upper part of the GL-R.	Connect the unit connection cable to the lower part of the GL-R. ☐ "Cable Installation" (page 3-11)	
		Transmitter and receiver are not the same model.	Check that all transmitter and receiver models are paired correctly.	
		When the GL-R operates in wire synchronization system		
		The synchronization wire is not wired correctly or disconnected.	Check the wiring of the synchronization wire. ☐ "Cable Color and Pin Position" (page 4-4)	
		When the GL-R operates in one-line system		
		The unit connection cable is connected to the transmitter.	Connect the unit connection cable to the receiver. Do not connect the unit connection cable to the transmitter. ☐ "Cable Installation" (page 3-11)	
		The series connection cable is connected to the lower part of the GL-R.	Connect the series connection cable to the upper part of the transmitter and receiver. ☐ "Cable Installation" (page 3-11)	
		When the GL-R is in series connection.		
		The sub unit is not connected correctly.	Check for the direction of the sub unit installation. Check whether the receiver of sub unit is connected to the transmitter of main unit. Check whether the total number of beam axes is more than 240. ☐ "Series connection" (page 2-3)	
		The sub unit is broken.	Check that the sub unit operates correctly when not in series connection.	
When the error is cleared by restarting the GL-R.				
E→4	Setting switch error	The configuration of the setting switch is out of specification.	Check the configuration of the setting switch. ☐ "Setting switch" (page 1-11)	
		The setting switch is configured to something other than Channel 0 in wire synchronization system.		
E→5	Configuration error	The configuration of the setting switch overlaps the configuration uploaded from the configuration software.	Modify the configuration of the setting switch or modify the configuration by the configuration software. ☐ "Setting switch" (page 1-11)	
		The unit configuration is different from the configuration uploaded from the software.	Check the model name of main unit and sub unit and whether the unit configuration from the software is identical to the actual unit configuration.	
		The upload of configuration has not been completed correctly when using the configuration software.	Upload the configuration again.	
E→7	Interlock error	Interlock mode selection input or reset input are wired incorrectly.	Rewire the interlock mode selection input or reset input correctly. ☐ "Interlock Function" (page 2-7)	



Indication	Error name	Cause	Check and corrective action
$E \rightarrow B$	EDM error	EDM input is not connected correctly.	If EDM function is needed, rewire the EDM correctly. If EDM function is not needed, rewire the EDM and AUX correctly or deactivate the EDM function by the configuration software. ☐ "External Device Monitoring (EDM Function)" (page 2-12)
		There is a welded contact on the external device.	Replace the external device.
$E \rightarrow 1 \rightarrow 0$	Receiver error	The receiver is affected by ambient light.	Shield the receiver from ambient light.
$E \rightarrow 1 \rightarrow 2$	Transmitter error	The transmitter is broken.	Replace the transmitter.
		When the error is cleared by restarting the GL-R.	
		The transmitter is affected by external noise.	Check for a noise source (inverter, servomotor, etc.) around the GL-R installation location and cables.
$E \rightarrow 1 \rightarrow 4$ $E \rightarrow 1 \rightarrow 5$	OSSD1 error OSSD2 error	When the error is cleared by restarting the GL-R.	
		OSSD is affected by external noise.	Check for a noise source (inverter, servomotor, etc.) around the GL-R installation location and cables.
		There is a voltage surge affecting the OSSD due to an inductive load.	When the load is inductive such as relay, use a load with a surge absorption device.
		The power supply voltage has fallen continuously or experienced a sudden drop.	Take measures by replacing the power supply, increasing the power capacity, or dedicating the power supply to the GL-R.
		When the error is not cleared by restarting the GL-R.	
		OSSD is short-circuited to 0 V or 24 V of power supply. OSSDs are short-circuited to each other. OSSD is short-circuited to other wires.	Rewire the OSSD correctly. ☐ "Examples of Wiring" (page 4-9)
		Too much current is flowing through the OSSD.	Check that the load does not consume more current than the OSSD can handle. ☐ "Specifications" (page 7-3)
$E \rightarrow 1 \rightarrow B$	Sub unit error	The sub unit is broken.	Replace the sub unit.
		When the error is cleared by restarting the GL-R.	
		The sub unit or series connection cable is affected by external noise.	Check for a noise source (inverter, servomotor, etc.) around the GL-R installation location and cables.
$E \rightarrow 2 \rightarrow 0$	Communication error <sup>*1</sup>	When the error is cleared by restarting the GL-R.	
		The synchronization wire is not wired correctly or is disconnected.	Check the connection of the synchronization wire.
		The synchronization lines in the cable are affected by external noise.	Check for a noise source (inverter, servomotor, etc.) around the GL-R installation location and cables.
		The power supply voltage has fallen continuously or experienced a sudden drop.	Take measures by replacing the power supply, increasing the power capacity, or dedicating the power supply to the GL-R.
		When the error is not cleared by restarting the GL-R.	
		The synchronization wire or series connection cable is not connected correctly or is disconnected.	Check the connection of the synchronization wire.
$E \rightarrow 2 \rightarrow 4$	Muting lamp disconnection error <sup>*2</sup>	The muting lamp is not connected correctly.	Check the connections.
		The muting lamp is broken.	Replace the muting lamp.

## 1 Troubleshooting

Indication	Error name	Cause	Check and corrective action
E → 2 → 5	Muting lamp over current error*2	The muting lamp is not connected correctly.	Check the connections.
		Too much power is consumed by the muting lamp.	Make sure the muting lamp does not consume more power than the GL-R can handle.
		The muting lamp is broken.	Replace the muting lamp.
E → 2 → 7	Synchronization beam axis error	When the GL-R operates in optical synchronization system, the fixed blanking or muting function is applied to both the upper and lower beam axes (for synchronization control).	Do not apply the fixed blanking or muting function to at least the upper or lower axis. Make the GL-R operate in one-line system or wire synchronization system. ☞ "Wiring System" (page 2-2)
E → 4 → □ : E → 5 → 9	System error	The power supply voltage has fallen continuously or experienced a sudden drop.	Take measures by replacing the power supply, increasing the power capacity, or dedicating the power supply to the GL-R.
		The GL-R is broken.	Replace the GL-R.

\*1 All indicators on the transmitter may turn OFF.

\*2 This error occurs only when the muting lamp error is configured to cause error condition by using the configuration software.

## If the GL-R is not in an error condition

Error name	Cause	Countermeasure
All Indicators are OFF.	The power is not turned ON or the power supply voltage is insufficient.	Adjust the power supply voltage to be within the range of specifications. Correctly wire the power supply. ☐ "Examples of Wiring" (page 4-9)
	Cables are disconnected or not connected correctly	Check the connection and reconnect the cables if necessary. ☐ "Cable Specification" (page 4-8)
The OSSD does not turn ON. (Center indicator lights in red or does not turn ON)	Are the beam axes properly aligned?	Perform optical alignment. ☐ "Optical Alignment" (page 3-19)
	Are there objects within the detection zone?	Remove all objects from the detection zone.
	Is the transmitter to receiver distance within the specified range?	Ensure the transmitter to receiver distance fall within the specified range.
	Have dust or other particles adhered to the detection surface, thus blocking the beam axes?	Clean the surface. Gently wipe the dirt away by using a cloth dampened with a mild detergent.
The OSSD does not turn ON. (Center indicator lights in green)	If the function indicator for interlock turns ON, the GL-R is in the interlock condition.	During manual start / manual restart mode, OSSD only turns ON when light is received from all of the beam axes and reset input is activated. ☐ "Interlock Function" (page 2-7)
	If the 7-segment display indicates "L", the wait input is active.	Correctly connect the wait input. ☐ "Wait Input Function" (page 2-34)
	When connected in series, are the beam axes for the other GL-R units aligned?	Check the status of the other GL-R units connected in series.
Beam axes are aligned, but sometimes OSSD turns OFF.	The receiver is affected by ambient light or light from other photoelectric devices.	Shield the receiver from ambient light. ☐ "Light Interference Prevention Method" (page 3-8)
	The synchronization wire in the communication cable is affected by external noise.	Check for noise around the cables.
The device connected to the OSSD turns ON and OFF very quickly (chattering).	The self-diagnosis function periodically turns OFF OSSD, so the device may be recognizing this short OFF signal.	Connect a device that will not detect the regular OSSD OFF signal. ☐ "OSSD" (page 2-6)
All indicator on the transmitter except "POWER" turn OFF.	The GL-R operates in optical synchronization system.	If you intend optical synchronization system, the GL-R operates correctly and there is nothing to do. If you do not intend optical synchronization system, check the connection of the synchronization 1 and 2 wire in the cable. ☐ "Wiring System" (page 2-2)
The GL-R does not go into the muted condition when the muting inputs are activated.	The 7-segment display and function indicators does not change when the muting inputs are activated.	
	Wires are not connected correctly.	Check the connection of wires. ☐ "2-6 Temporary Suspension of Safety Function" (page 2-13)
	<ul style="list-style-type: none"> <li>External device connected to the muting inputs is broken.</li> <li>Wires for muting inputs are disconnected.</li> <li>Muting inputs are broken.</li> </ul>	<ul style="list-style-type: none"> <li>Connect another external device to the muting inputs.</li> <li>Connect another unit connection cable.</li> <li>Connect another GL-R unit.</li> </ul>
	The 7-segment display and function indicators change when the muting inputs are activated.	
	Conditions for initiation of muting are not fulfilled.	Check the muting conditions. ☐ "Detailed operation" (page 2-14)
	Combination of the muting bank inputs is not correct.	Check the muting bank inputs when the muting bank function is applied. ☐ "Partial muting function / Muting bank function" (page 2-16)

## Checklist before operation

You are fully responsible for performing the risk assessment on your machine application, taking into account performing maintenance and inspections, which are a critical factor for appropriate risk assessment. In addition, it is the responsibility of the responsible personnel to train the machine operators regarding inspection and maintenance of the machine and the GL-R.

### ■ Inspection before operation (Initial inspection)

When installation of the GL-R is completed, the responsible personnel must verify the operation of the GL-R in accordance with the checklist shown below. Note that the following inspection items comprise only a bare minimum inspection. KEYENCE Corporation strongly recommends including the necessary checking items into this checklist based on the judgment of the responsible personnel since additional criteria may be necessary depending on both the machine to which the GL-R is installed and the laws, rules, regulations and standards in the country or region in which the GL-R is used/installed.

#### (1) Pre-check for installation condition

- The machine under GL-R control can be caused to stop running by the OFF-state of OSSD.
- The GL-R is installed so that the machine operator cannot go into or approach the hazardous area without passing through the detection zone.
- The interlock reset mechanism is installed so that it cannot be operated if there are any personnel within the hazardous area.
- The device to activate the override is installed so that it cannot be operated if there are any personnel within the hazardous area.
- The GL-R has been installed at a distance greater than or equal to the minimum safety distance required.
- If there are glossy surfaces nearby, move them so that they are beyond the minimum installation distance according to "Installation Distance From Glossy Surfaces".
- The GL-R is installed at a location free from light interference, for example fluorescent lamps.
- The transmitters and receivers are paired correctly.
- The beam axis spacing (detection capability) is the same between the transmitter and the receiver when installing the GL-R.
- Muting devices (sensor, switch, etc.) used to establish muting status and the installation method fulfill the conditions described in this manual and all the requirements stipulated in laws, legislations, standards, regulations, etc. of the countries or regions where the devices are used.
- Devices used to establish override status and the installation method fulfill the conditions described in this manual and all the requirements stipulated in laws, legislations, standards, regulations, etc. of the countries or regions where the devices are used.
- When the reduced resolution function is applied, the safety distance is accurately calculated based on the detection capability, and the GL-R is installed at a distance greater than or equal to the minimum safety distance away from the hazardous zone or hazard.
- Risk assessment was performed on your own responsibility based on your machine application, and then the installation of GL-R was also based on its result.
- When the fixed blanking function is applied, a hazardous clearance that is not protected by the GL-R may be generated between the obstacle and the GL-R. When such a hazardous clearance is generated, an additional protective device such as a safeguard is installed.

**(2) Pre-check for wiring**

- ❑ The power supply for GL-R is 24 V DC and fulfills the conditions for power supply specified in this manual.
- ❑ The transmitter and receiver cables are installed correctly.
- ❑ The two of OSSD outputs provided in the GL-R are both used as a safety-related machine control system.
- ❑ The polarity is not reversed with the connection to the power supply.
- ❑ In case of using PNP output type cable, the OSSD is not short-circuited to +24 V, and the load is between the OSSD and 0 V.
- ❑ In case of using NPN output type cable, the OSSD is not short-circuited to 0 V, and the load is between the OSSD and +24 V.
- ❑ When two or more GL-R are connected in series, they are connected using the dedicated series connection cable, which is not cut or extended.
- ❑ The AUX output, error output, muting state output, alert output, Clear/Blocked state output and interlock-reset-ready output are not used as safety outputs for the safety-related control systems.
- ❑ The cable sheaths are not damaged. The protection against the disconnection or short-circuit of cable, which might be caused by crushing or being caught in a machine, is taken into account.
- ❑ If two or more sets of the GL-R units are used in the vicinity of each other, the protection measures against light interference is done through a series connection method or light interference prevention method.
- ❑ "Non-safety-related functions (output and input)" described in this manual are not incorporated in the safety-related machine control system.

**(3) Pre-check test while the machine is stopped.**

You should do the following pre-check test with the test piece in order to make sure the operation of the GL-R while the machine is stopped. In case of the detection capability of 45 mm, you should use the test piece with a diameter of 45 mm.

The OSSD indicator on the GL-R lights in red and the OSSD turns OFF while the test piece is present in the detection zone. The following figure shows the movement procedure of the test piece.

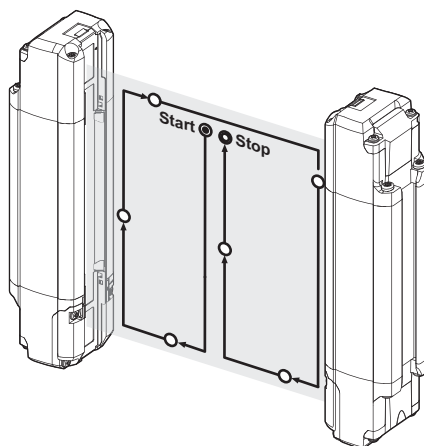

- ❑ The OSSD indicator and all bar LEDs light in green if no test piece is present in the detection zone.
- ❑ When the EDM function is applied, the GL-R goes to an error condition and the OSSD indicator on the GL-R lights in red if the EDM input opens while the test piece is present in the detection zone.

- The bar LEDs lights in green, the OSSD indicator continues to light in red, and the interlock indicator lights in yellow, if the test piece is removed from the detection zone. This is only applicable in case of manual restart mode.
- The OSSD indicator lights in green and the interlock indicator lights OFF if the reset input is activated. This is only applicable in case of manual restart.

#### **(4) Pre-check test while the machine is operating.**

The purpose of this pre-check test is to make sure that the machine (hazards) stops its operation. This test must be done after you completely make sure that there is nobody in the hazardous zone.

- The machine stops if the test piece is present in the detection zone. It is recommended to try three locations of test piece: near the transmitter, near the receiver, and in the central area of the detection zone.
- The machine (hazard) still stops its operation as long as the test piece is present in the specified protection zone. This test should be done for the whole detection zone.
- The machine (hazard) stops its operation when the power for the GL-R is disconnected.
- Minimum safety distance is ensured, which has been calculated according to the laws, regulations, and standards of the country and region in which the GL-R is installed.

### **■ Inspection prior to daily operation (Daily inspection)**

You should check the GL-R operation and the machine operation according to the following checklist prior to daily operation.

Note that the following inspection items comprise only a bare minimum inspection. KEYENCE Corporation strongly recommends including the necessary checking items into this checklist based on the judgment of the responsible personnel since additional criteria may be necessary depending on both the machine to which the GL-R is installed and the laws, rules, regulations and standards in the country or region in which the GL-R is used/installed.

The result of this inspection must be kept on record along with the machine log.

#### **(1) Pre-check for installation condition**

- The GL-R is installed so that the machine operator cannot go into or approach the hazardous area without passing through the detection zone.
- The GL-R has been installed at a distance greater than or equal to the minimum safety distance required.
- When the reduced resolution function is applied, the safety distance is accurately calculated based on the detection capability, and the GL-R is installed at a distance greater than or equal to the minimum safety distance away from the hazardous zone or hazard.
- When the fixed blanking function is applied, a hazardous clearance that is not protected by the GL-R may be generated between the obstacle and the GL-R. When such a hazardous clearance is generated, an additional protective device such as a safeguard is installed.
- The GL-R is installed at a location free from light interference, for example fluorescent lamps.
- The cable sheaths are not damaged. The protection against the disconnection or short-circuit of cable, which might be caused by crushing or being caught in a machine, is taken into account.
- Additionally, you should perform the following inspections as described in "Inspection before operation".
  - (3) Pre-check test while the machine is stopped
  - (4) Pre-check test while the machine is operating
- There is no change of installation that would influence the result of your original risk assessment.

## ■ Regular (periodical) inspection

The responsible personnel must perform a regular inspection.

It is recommended to perform a regular inspection at least once every six months.

Note that the following inspection items comprise only a bare minimum inspection. KEYENCE Corporation strongly recommends including the necessary checking items into this checklist based on the judgment of the responsible personnel since additional criteria may be necessary depending on both the machine to which the GL-R is installed and the laws, rules, regulations and standards in the country or region in which the GL-R is used/installed.

The result of this inspection must be kept on record along with the machine log.

### (1) Additional inspection items

- The actual distance between the hazardous zone or hazards and the GL-R still keeps greater than the calculated safety distance.
- When the reduced resolution function is applied, the safety distance is accurately calculated based on the enlarged detection capability, and the GL-R is installed at a distance greater than or equal to the minimum safety distance away from the hazardous zone or hazard.
- When the fixed blanking function is applied, a hazardous clearance that is not protected by the GL-R may be generated between the obstacle and the GL-R. When such a hazardous clearance is generated, an additional protective device such as a safeguard is installed.
- The stop time of the machine connected to the GL-R has not increased.
- There are no loose screws in the mounting bracket.
- The unit connection cable or the series connection cable is fastened tightly to the GL-R with no loose screws.
- The OSSD is connected correctly to the machine.
- There is no damage to the GL-R that may influence IP65 structure.
- The surface of the GL-R is not polluted or damaged.
- Beam axes must be aligned. If it is out of alignment, beam axes are aligned.
- There is no change of installation that would influence the result of your original risk assessment.

# Revision History

---

Date	Revision	Revision contents
May 2012	Official release	
June 2012	2nd edition	
October 2012	3rd edition	Contents revised and added.
February 2013	4th edition	Mounting bracket added and contents revised.
March 2014	5th edition	
May 2015	7th edition	
July 2016	8th edition	
March 2017	9th edition	
June 2017	10th edition	



# WARRANTIES AND DISCLAIMERS

- (1) KEYENCE warrants the Products to be free of defects in materials and workmanship for a period of one (1) year from the date of shipment. If any models or samples were shown to Buyer, such models or samples were used merely to illustrate the general type and quality of the Products and not to represent that the Products would necessarily conform to said models or samples. Any Products found to be defective must be shipped to KEYENCE with all shipping costs paid by Buyer or offered to KEYENCE for inspection and examination. Upon examination by KEYENCE, KEYENCE, at its sole option, will refund the purchase price of, or repair or replace at no charge any Products found to be defective. This warranty does not apply to any defects resulting from any action of Buyer, including but not limited to improper installation, improper interfacing, improper repair, unauthorized modification, misapplication and mishandling, such as exposure to excessive current, heat, coldness, moisture, vibration or outdoors air. Components which wear are not warranted.
- (2) KEYENCE is pleased to offer suggestions on the use of its various Products. They are only suggestions, and it is Buyer's responsibility to ascertain the fitness of the Products for Buyer's intended use. KEYENCE will not be responsible for any damages that may result from the use of the Products.
- (3) The Products and any samples ("Products/Samples") supplied to Buyer are not to be used internally in humans, for human transportation, as safety devices or fail-safe systems, unless their written specifications state otherwise. Should any Products/Samples be used in such a manner or misused in any way, KEYENCE assumes no responsibility, and additionally Buyer will indemnify KEYENCE and hold KEYENCE harmless from any liability or damage whatsoever arising out of any misuse of the Products/Samples.
- (4) **OTHER THAN AS STATED HEREIN, THE PRODUCTS/SAMPLES ARE PROVIDED WITH NO OTHER WARRANTIES WHATSOEVER. ALL EXPRESS, IMPLIED, AND STATUTORY WARRANTIES, INCLUDING, WITHOUT LIMITATION, THE WARRANTIES OF MERCHANTABILITY, FITNESS FOR A PARTICULAR PURPOSE, AND NON-INFRINGEMENT OF PROPRIETARY RIGHTS, ARE EXPRESSLY DISCLAIMED. IN NO EVENT SHALL KEYENCE AND ITS AFFILIATED ENTITIES BE LIABLE TO ANY PERSON OR ENTITY FOR ANY DIRECT, INDIRECT, INCIDENTAL, PUNITIVE, SPECIAL OR CONSEQUENTIAL DAMAGES (INCLUDING, WITHOUT LIMITATION, ANY DAMAGES RESULTING FROM LOSS OF USE, BUSINESS INTERRUPTION, LOSS OF INFORMATION, LOSS OR INACCURACY OF DATA, LOSS OF PROFITS, LOSS OF SAVINGS, THE COST OF PROCUREMENT OF SUBSTITUTED GOODS, SERVICES OR TECHNOLOGIES, OR FOR ANY MATTER ARISING OUT OF OR IN CONNECTION WITH THE USE OR INABILITY TO USE THE PRODUCTS, EVEN IF KEYENCE OR ONE OF ITS AFFILIATED ENTITIES WAS ADVISED OF A POSSIBLE THIRD PARTY'S CLAIM FOR DAMAGES OR ANY OTHER CLAIM AGAINST BUYER.** In some jurisdictions, some of the foregoing warranty disclaimers or damage limitations may not apply.

## **BUYER'S TRANSFER OBLIGATIONS:**

If the Products/Samples purchased by Buyer are to be resold or delivered to a third party, Buyer must provide such third party with a copy of this document, all specifications, manuals, catalogs, leaflets and written information provided to Buyer pertaining to the Products/Samples.

Specifications are subject to change without notice.

## KEYENCE CORPORATION

1-3-14, Higashi-Nakajima, Higashi-Yodogawa-ku, Osaka, 533-8555, Japan PHONE: +81-6-6379-2211

[www.keyence.com](http://www.keyence.com)

### AUSTRIA

Phone: +43 22 36-3782 66-0

### BELGIUM

Phone: +32 1 528 1222

### BRAZIL

Phone: +55-11-3045-4011

### CANADA

Phone: +1-905-366-7655

### CHINA

Phone: +86-21-3357-1001

### CZECH REPUBLIC

Phone: +420 222 191 483

### FRANCE

Phone: +33 1 56 37 78 00

### GERMANY

Phone: +49 6102 36 89-0

### HONG KONG

Phone: +852-3104-1010

### HUNGARY

Phone: +36 1 802 73 60

### INDIA

Phone: +91-44-4963-0900

### INDONESIA

Phone: +62-21-2966-0120

### ITALY

Phone: +39-02-6688220

### KOREA

Phone: +82-31-789-4300

### MALAYSIA

Phone: +60-3-7883-2211

### MEXICO

Phone: +52-55-8850-0100

### NETHERLANDS

Phone: +31 40 20 66 100

### PHILIPPINES

Phone: +63-(0)2-981-5000

### POLAND

Phone: +48 71 36861 60

### ROMANIA

Phone: +40 269-232-808

### SINGAPORE

Phone: +65-6392-1011

### SLOVAKIA

Phone: +421 2 5939 6461

### SLOVENIA

Phone: +386 1-4701-666

### SWITZERLAND

Phone: +41 43-45577 30

### TAIWAN

Phone: +886-2-2721-8080

### THAILAND

Phone: +66-2-369-2777

### UK & IRELAND

Phone: +44-1908-696900

### USA

Phone: +1-201-930-0100

### VIETNAM

Phone: +84-4-3772-5555

