

Superior Clamping and Gripping



Product data sheet

Application kit MTB Double Gripper JGP-P 64

MTB

Application kit

Modular. Flexible. Easy.

MTB

The MTB application kits enable quick and easy implementation of automated machine loading. The specific application kits take on the important key role of workpiece handling and workpiece clamping. They seamlessly fit into the machine environment.

Field of application

Handling tasks in the environment of cutting machines with harsh ambient conditions and contamination by chips, coolant and oil.

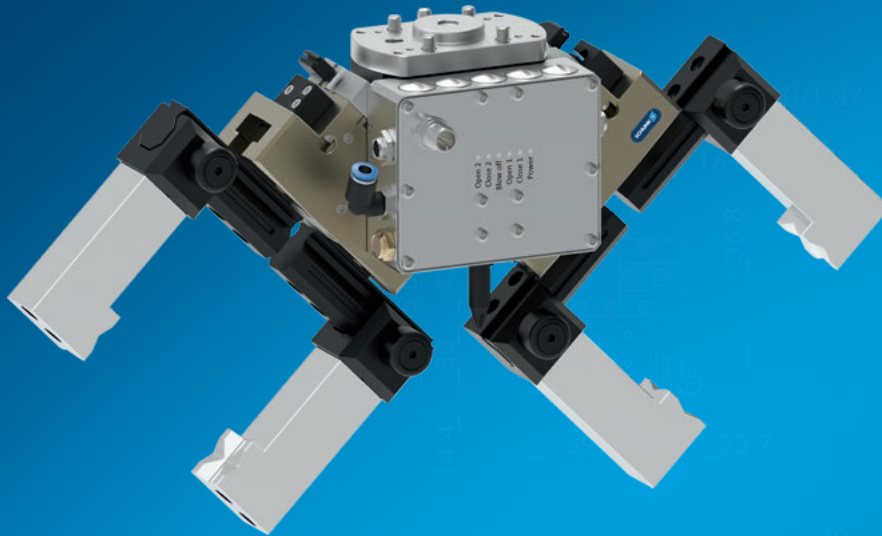

Advantages – Your benefits

The perfect match. Due to the high application specialization of the application kits, you do not have to search long for a suitable solution. Use your time for more important things.

Increased productivity. You don't have an employee available for a third shift? Let the robot work for you.

Relieve employees. Protect your employees from dirty, dangerous and tedious tasks such as manual loading and cleaning operations.

Plug & work. The seamless integration of the components into the robot control system saves you from having to carry out extensive integration work.

Functional description

The robot is an important key element in automated machine loading. It is used for feeding raw parts and also removes the finish-machined products. The MTB application kits combine the SCHUNK SYNERGY from gripping and

clamping technology and provide support both when clamping the workpieces within the machine and when handling them with the robot.

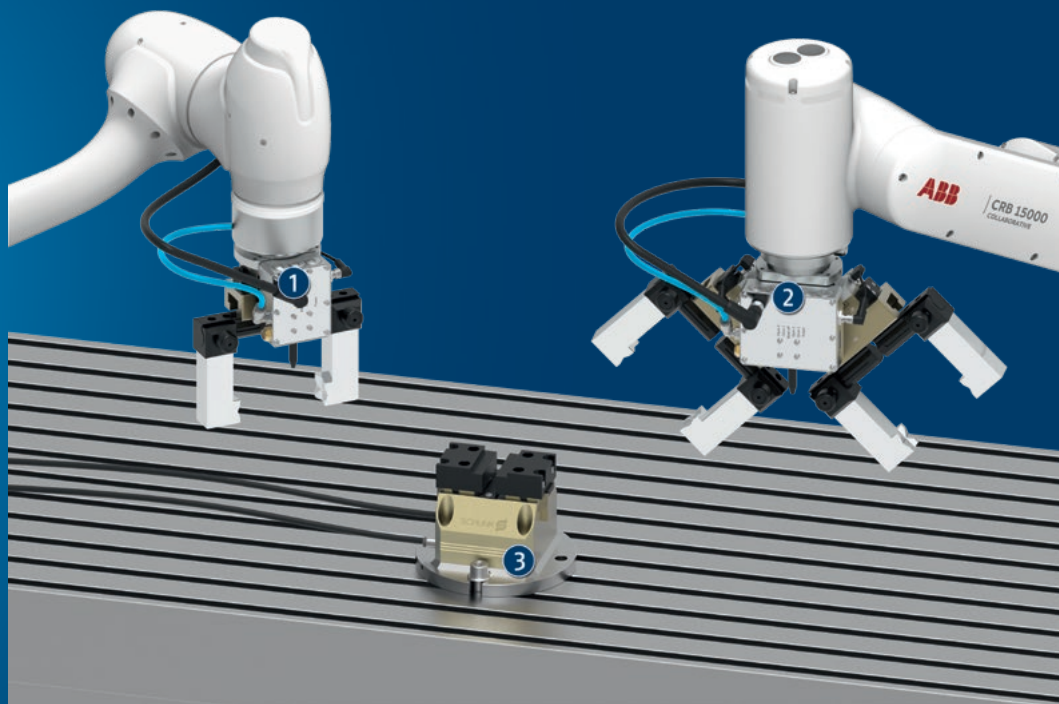

- ① **Single gripper**
Perfect for use in confined spaces

- ② **Double gripper**
Loading and unloading in just one cycle. Increase in machine productivity.

- ③ **Clamping force block**
Reliable holding of the workpiece during machining

Detailed functional description

Single grippers and double grippers

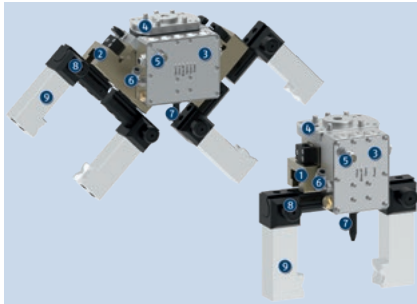

Single grippers (1) are perfect for confined spaces and allow easy entry into automated machine loading. Double grippers (2) can increase machine productivity as the machine is loaded and unloaded in just one cycle.

- 1 Single gripper
- 2 Double gripper
- 3 Sealed valve box with status LED
- 4 Mechanical adapter for robot connection
- 5 M12 connector for electrical connection
- 6 Push-in fitting for compressed air connection
- 7 Pre-assembled blow-off nozzle
- 8 Universal intermediate jaw UZB (available as an accessory)
- 9 Universal top jaw AUB JGP-P (available as an accessory)

Automated clamping force block with valve clusters



The interplay of the grippers and automated clamping force block PGS3 (1) increases the productivity of the metal cutting machine. The integration time is minimized by the valve block included in the scope of delivery.

- 1 TANDEM PGS3 clamping force block
- 2 Integrated flange for direct mounting on the machine table
- 3 Sealed valve box with status LED prepared for field mounting
- 4 Push-in fitting for compressed air connection
- 5 M12 connector for electrical connection
- 6 Top jaw blanks KTR-H for individual reworking (available as accessories)

Supported robots



The MTB application kits are available as standard for a wide range of robots from different manufacturers. These include robots from the manufacturers Universal Robots, FANUC, Doosan Robotics, Techman Robot, OMRON and ABB. A detailed list of compatible robots can be found in the accessories section. Your robot is not included? Please contact us for details!

Robot connection packages



Combining a suitable connection package with the used robot is the only way to enable seamless interaction between the component and the robot. The scope of delivery can be taken from the list. The robot connection kit for the clamping force block PGS3 does not include an adapter plate. Metal protection hoses are also included to provide extra protection for the plastic hoses in the machine room.

- 1 Adapter plate matching the drilling pattern of the respective robot
- 2 USB stick for robot software
- 3 Velcro tapes for fastening cables and hoses to the robot
- 4 Connection cables
- 5 Plastic hose

Stroke adjustment via universal intermediate jaw UZB

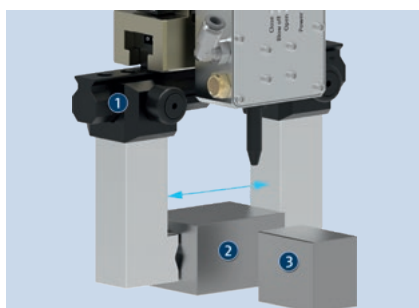

The universal intermediate jaw UZB (1) allows fast, tool-free, safe moving of top jaws on the gripper. This means that a gripper can be adjusted to a new workpiece size in just a few seconds.

- 1 UZB universal intermediate jaw
- 2 Long workpiece
- 3 Short workpiece

Tool-free jaw quick-change system BSWS-M

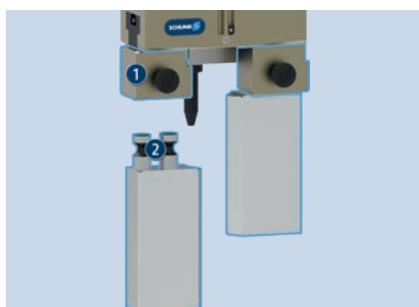

The tool-free jaw quick-change system BSWS-M allows top jaws to be exchanged on the gripper manually, rapidly and without tools. If the geometry of the workpiece or the gripping process changes, the gripper can be converted to new top jaws at the push of a button, thereby increasing the variety of workpieces that can be handled.

- 1 Base BSWS-BM
- 2 Adapter pin BSWS-A

General notes about the series

Housing material: Aluminum

Base jaw material: Steel

Actuation: pneumatic, with filtered compressed air as per ISO 8573-1:2010 [3:4:3]

Warranty: 24 months

Gripping force: is the arithmetic sum of the individual force applied to each jaw at distance P (see illustration).

Finger length: is measured from the reference surface as the distance P in direction to the main axis. The maximum permissible finger length applies until the nominal operating pressure is achieved. With higher pressures, the finger length must be reduced proportionally to the nominal operating pressure.

Repeat accuracy: is defined as a distribution of the end Position for 100 consecutive strokes.

Workpiece weight: is calculated for force-fit gripping with a coefficient of static friction of 0.1 and a safety factor of 2 against workpiece slippage at acceleration due to gravity g. For form-fit or capture gripping, there are significantly higher permissible workpiece weights.

Closing and opening times: are movement times of the base jaws only, without application-specific gripper fingers, incl. valve switching times. PLC reaction times are not included in the above-mentioned times and must be taken into consideration when determining cycle times.

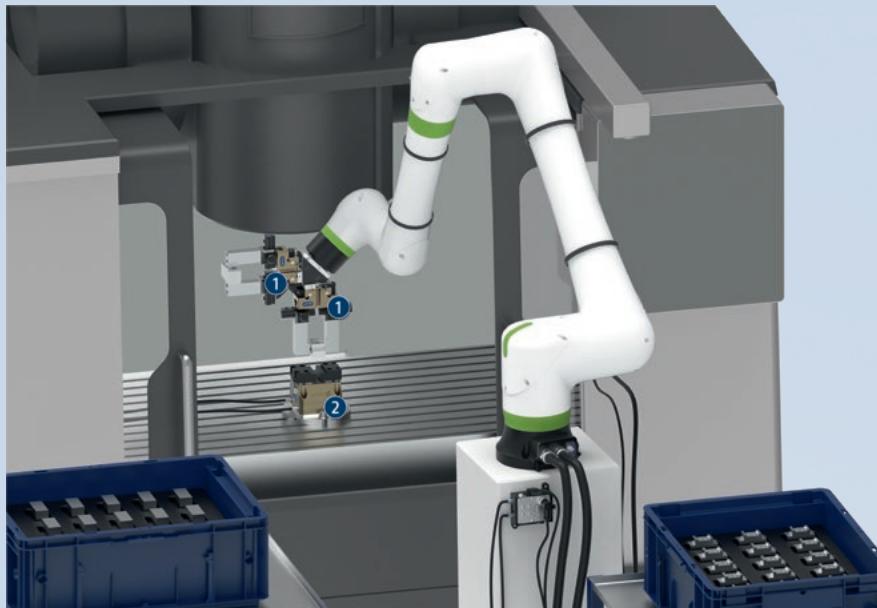

Application example

Loading and unloading of a machine tool optimized for the cycle time. By using two grippers on the robot, the machine tool can be loaded automatically in a way that is optimized for the cycle time, and productivity can be increased. After the finished part has been removed from the first gripper, the automated clamping force block is cleaned of coolant and chips via the integrated blow-off nozzle of the double gripper. After that, the second gripper can directly insert the unmachined part and the machining process can be started. The finished part is then deposited and the next unmachined part is picked up again in parallel with the machining of the workpiece.

- ❶ 2-finger parallel gripper JGP-P
- ❷ TANDEM PGS3 clamping force block

SCHUNK offers more ...

The following components make the product even more productive – the suitable addition for the highest functionality, flexibility, reliability, and controlled production.

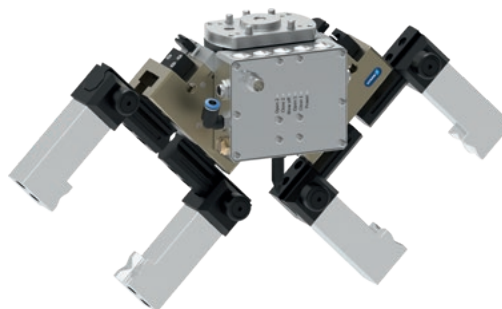

Universal intermediate jaw

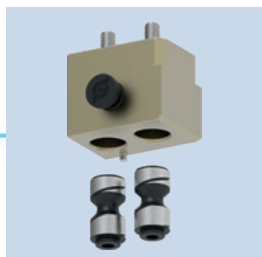

Jaw quick-change system



Finger blank



Finger blank with jaw quick-change system

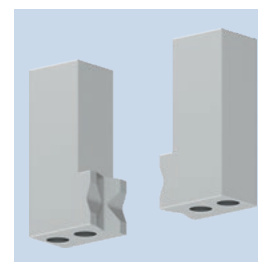

Attachment fingers

① For more information on these products can be found on the following product pages or at [schunk.com](https://www.schunk.com).

Options and special information

Food-grade lubrication: The product contains food-compliant lubricants as standard. The requirements of EN 1672-2:2020 are not fully met. The relevant NSF certificates are available at <https://info.nsf.org/USDA/Listings.asp> using the lubricant information in the operating manual.

MTB Double Gripper JGP-P 64

Application kit



Gripping force O.D. gripping

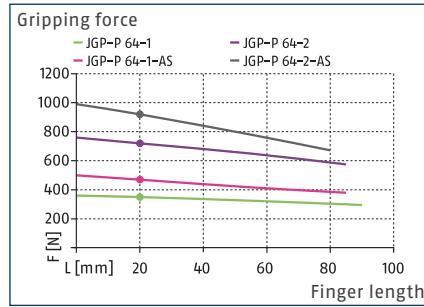

Gripping force I.D. gripping

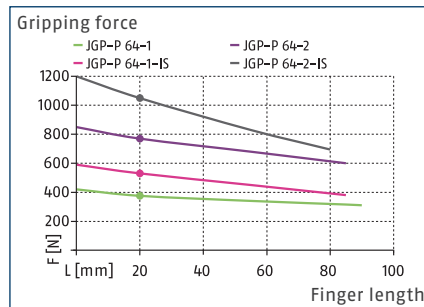

Dimensions and maximum loads

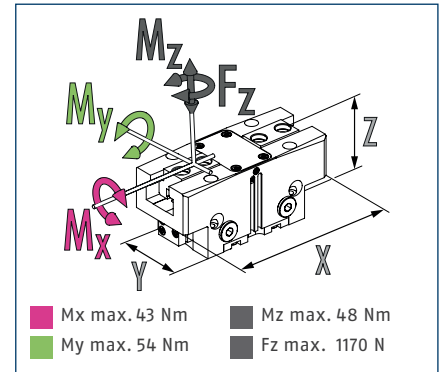

① The indicated moments and forces are static values, apply for each base jaw and may appear simultaneously. Loads may additionally occur to the moment produced by the gripping force itself.

Technical data

Description	MTB DG-JGP-P 64-1	
ID	1490830	
General operating data		
Sensor system	pre-assembled, 2-way magnetically adjustable	
Dimensions X x Y x Z	[mm]	178 x 96 x 117
Weight	[kg]	1.62
Mechanical operating data		
Stroke per jaw	[mm]	6
Closing/opening force	[N]	350/375
Recommended workpiece weight	[kg]	1.75
Max. permissible finger length	[mm]	90
Max. permissible weight per finger	[kg]	0.4
IP protection class of gripper	40	
IP protection class of valve box	67	
Min./max. ambient temperature	[°C]	5/50
Min./nom./max. operating pressure	[bar]	2.5/6/7
Min./max. air purge pressure	[bar]	0.5/1
Closing/opening time	[s]	0.05/0.05
Cylinder volume per double stroke	[cm³]	15
Fluid consumption blow-off nozzle	[cm³/s]	3000
Repeat accuracy	[mm]	0.01
Cable connector	M12, A-coded	
Electrical operating data		
Nominal voltage	[V DC]	24
Nominal current	[mA]	170
Max. current	[mA]	500
Communication interface	digital I/O	
Number of digital I/O	6/4	

① The full gripping force as per the data table will possibly become effective after a few hundred gripping cycles. Compatibility with a robot is only given in conjunction with a corresponding connection package.

Main view

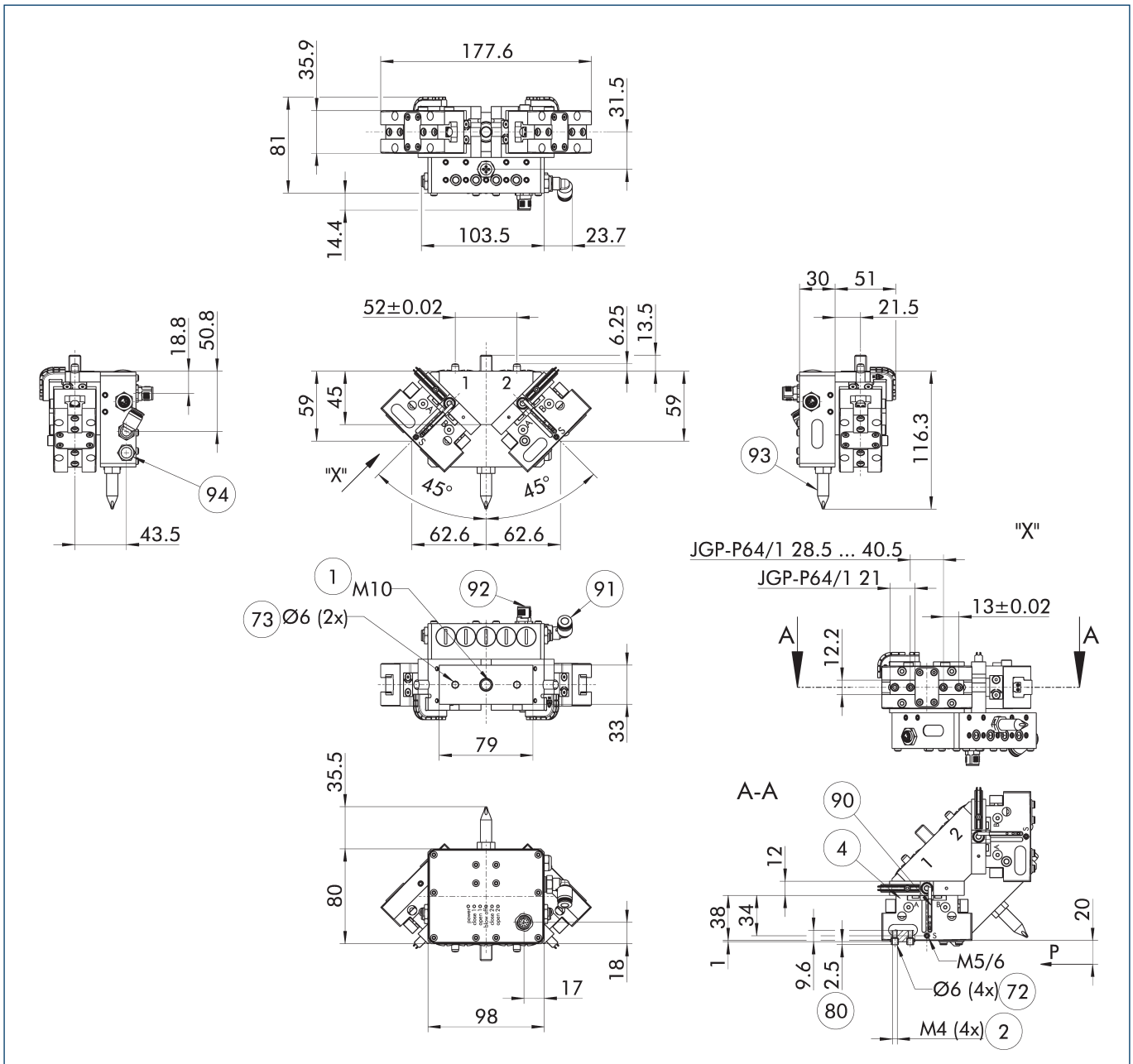

The drawing shows the gripper in the basic version with closed jaws, without dimensional consideration of the options described below.

- | | | | |
|----|--|----|--|
| S | Air purge connection | 90 | Sensor MMS 22.. |
| 1 | Gripper connection | 91 | Plug-in connection Ø 6 mm (air connection) |
| 2 | Finger connection | 92 | M12 connector, A-coded (electrical connection) |
| 4 | Grippers | 93 | Blow-off nozzle |
| 72 | Fit for centering sleeves | 94 | Exhaust air/silencer |
| 73 | Fit for centering pins | | |
| 80 | Depth of the centering sleeve hole in the counter part | | |

MTB Double Gripper JGP-P 64

Application kit

Maximum permitted finger projection

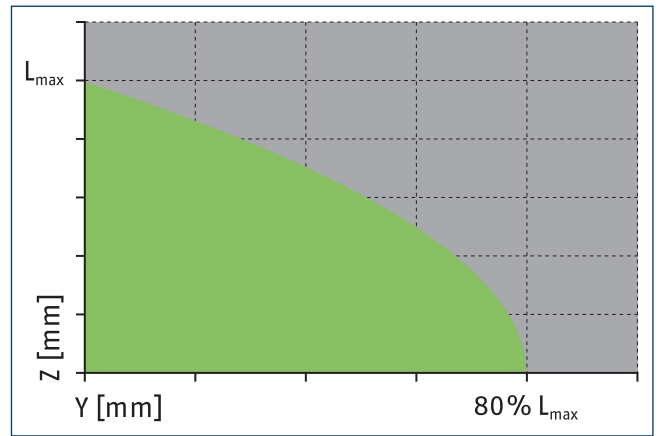
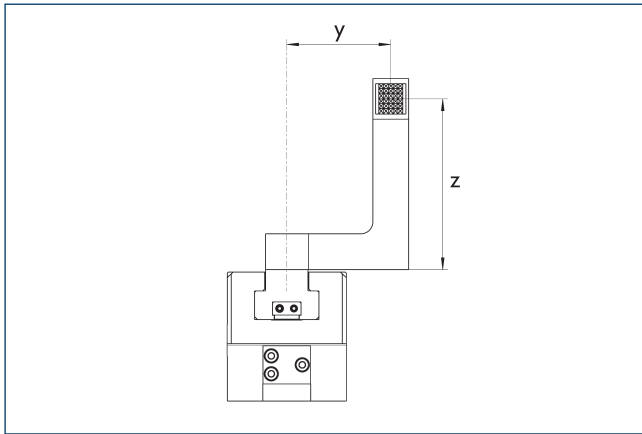

■ Permitted range

■ Inadmissible range

L_{max} is equivalent to the maximum permitted finger length, see the technical data table.

Robot connection package



Robot connection packages contain all the necessary components to successfully adapt the gripper to the robot and to put it into operation.

Description	ID	Manufacturer	Series	Model
Robot connection package				
MTB CNK-SG/DG-RF1	1490834	Universal Robots	e-Series	UR5e, UR10e, UR16e
MTB CNK-SG/DG-RF1	1490834	FANUC	CRX	CRX-series
MTB CNK-SG/DG-RF1	1490834	ABB	GoFa	CRB 15000
MTB CNK-SG/DG-RF1	1490834	Techman Robot	TM	TM5, TM12, TM14
MTB CNK-SG/DG-RF1	1490834	OMRON	TM	TM5, TM12, TM14
MTB CNK-SG/DG-RF1	1490834	Doosan Robotics	A-Serie, M-Serie, H-Serie	M609, M1509, M1013, M0617, A0509, A0509s, A0912, A0912s, H2017, H2515

① The scope of delivery of the robot connection package includes the following contents: mechanical adapter incl. fastening material, connection cable, compressed air hose, Velcro straps for fastening cables and hoses to the robot, USB flash drive. The instructions in the robot-specific commissioning instructions must be observed. You will find the robot-specific software and commissioning instructions at www.schunk.com/mtb-downloads.

Jaw quick-change system BSWS-M

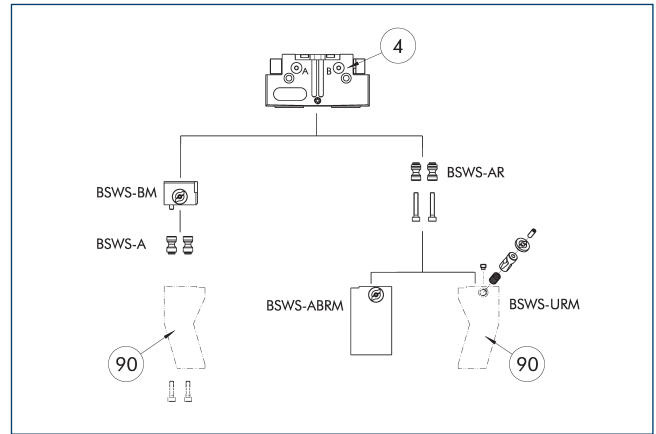

④ Grippers

⑨ Customized gripper fingers

There are various jaw quick-change systems available for the gripper. For detailed information, please refer to the corresponding product.

Description	ID	Scope of delivery
Jaw quick-change system adapter pin		
BSWS-A 64	0303022	2
BSWS-AR 64	0300092	2
Quick-change jaw system base		
BSWS-BM 64	1313900	1
Jaw quick-change system finger blank		
BSWS-ABRM-PGZN-plus 64	1420851	1
Jaw quick-change system locking mechanism		
BSWS-URM 64	1398401	1

① If the operating pressure is higher than 6 bar, suitability for use beyond the application limits must be checked. Only systems that are listed in the table, can be used.

Fields of application

Series	Size	Variant	Suitability
MTB	Double Gripper JGP-P 64	-1 (6 bar)	■■■■
Legend			
■■■■			Can be combined without restrictions
■■□□			Use with restrictions (see loading limits)
□□□□			cannot be combined

The load limits for describing the application limits can be found in the catalog chapter of the corresponding accessories.

MTB Double Gripper JGP-P 64

Application kit

UZB 64 universal intermediate jaw

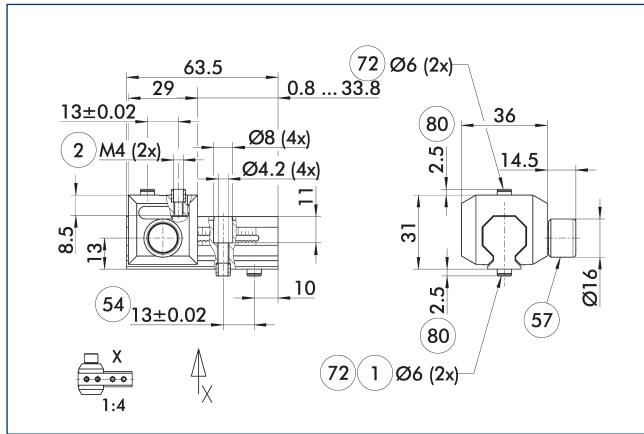

- ① Gripper connection
- ② Finger connection
- ⑤4 Optional right or left connection
- ⑤7 Locking
- ⑦2 Fit for centering sleeves
- ⑧0 Depth of the centering sleeve hole in the counter part

The drawing shows the UZB universal intermediate jaw.

Description	ID	Grid dimension
[mm]		
Universal intermediate jaw		
UZB 64	0300042	1.5
Finger blank		
ABR-PGZN-plus 64	0300010	
SBR-PGZN-plus 64	0300020	

- ① If the operating pressure is higher than 6 bar, suitability for use beyond the application limits must be checked.

Fields of application

Series	Size	Variant	Suitability
MTB	Double Gripper JGP-P 64	-1 (6 bar)	■■■■■
Legend			
■■■■■	Can be combined without restrictions		
■■■□	Use with restrictions (see loading limits)		
□□□□	cannot be combined		

The load limits for describing the application limits can be found in the catalog chapter of the corresponding accessories.

Finger blanks ABR/SBR-PGZN-plus 64

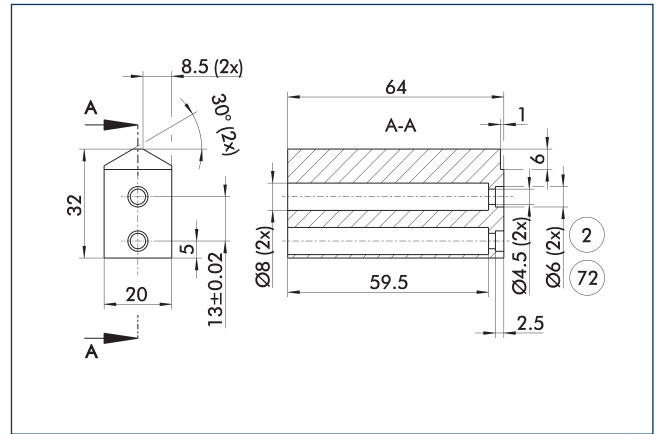

- ② Finger connection
- ⑦2 Fit for centering sleeves

The drawing shows the finger blank which can be reworked by the customer.

Description	ID	Material	Scope of delivery
Finger blank			
ABR-PGZN-plus 64	0300010	Aluminum (3.4365)	1
SBR-PGZN-plus 64	0300020	Steel (1.7131)	1

- ① When finger blanks are used, the closing stroke of individual gripper series may be limited. Please check this in detail in advance using the CAD data and adjust the reworking of the fingers accordingly.



SCHUNK GmbH & Co. KG
Spann- und Greiftechnik

Bahnhofstr. 106 - 134
D-74348 Lauffen/Neckar
Tel. +49-7133-103-0
Fax +49-7133-103-2399
info@de.schunk.com
schunk.com

Folgen Sie uns | *Follow us*

